



# hydrovar® X Smart Motor

## Specifications

### **EXM143-145/4.020BH4**

2 HP, 1200-2000 RPM, 3PH, 60HZ, 380-480V

143-145 Frame, TEFC

## hydrovar X Nameplate Legend

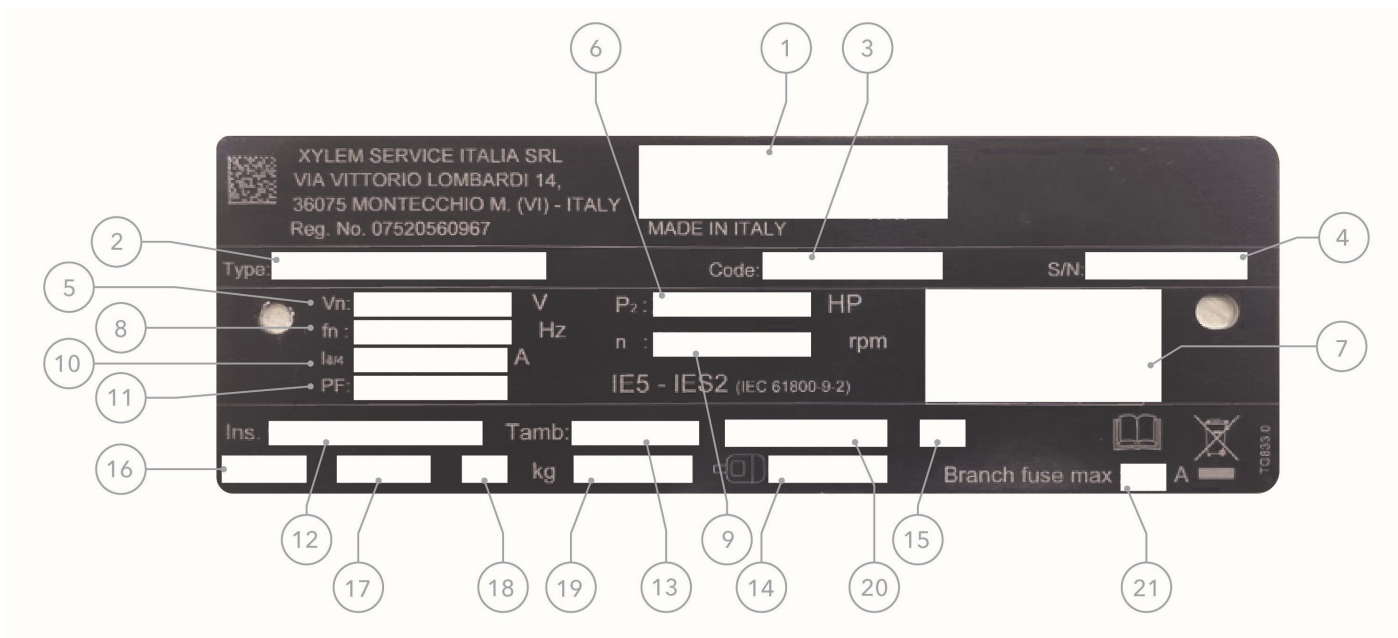

- |   |  |
|---|--|
| 1. Certification markings (CE, UKCA, UL Recognized)                     | 11. Power factor                         |
| 2. Motor type   | 12. Insulation class                     |
| 3. Motor code   | 13. Ambient operating temperature        |
| 4. Unique motor serial number   | 14. Non-drive end bearing                |
| 5. Voltage range  | 15. Service factor                       |
| 6. Output power (kW / HP)   | 16. IP environmental protection rating   |
| 7. Full load rated PDS efficiency (motor and drive combined efficiency) | 17. NEMA environmental protection rating |
| 8. Frequency compatibility  | 18. Weight                               |
| 9. Full load rated speed  | 19. Drive end bearing                    |
| 10. Full load rated current range                                       | 20. Duty cycle rating                    |
|   | 21. Circuit protection requirement       |

## hydrovar X Nameplate Information (representative example)\*

**XYLEM SERVICE ITALIA SRL**  
 VIA VITTORIO LOMBARDI 14,  
 36075 MONTECCHIO M. (VI) - ITALY  
 Reg. No. 07520560967

  
**MADE IN ITALY**

Type: EXM143-145/4.020BH4

Code:

S/N:

Vn: 3~ 380-480	V	P <sub>2</sub> : 1.5	kW/ 2	HP	<table border="1" style="border-collapse: collapse; width: 100%;"> <tr> <td style="padding: 2px;">PDS Eff. 460V</td> <td style="padding: 2px;">4/4</td> </tr> <tr> <td style="padding: 2px;">1500 rpm</td> <td style="padding: 2px;">82.2</td> </tr> <tr> <td style="padding: 2px;">1800 rpm</td> <td style="padding: 2px;">85.1</td> </tr> <tr> <td style="padding: 2px;">2000 rpm</td> <td style="padding: 2px;">86.7</td> </tr> </table>	PDS Eff. 460V	4/4	1500 rpm	82.2	1800 rpm	85.1	2000 rpm	86.7
PDS Eff. 460V	4/4												
1500 rpm	82.2												
1800 rpm	85.1												
2000 rpm	86.7												
fn: 50/60	Hz	n: 1500 - 2000		rpm									
I <sub>4/4</sub> : 4.0-3.8	A												
PF: 0.57		IE5 - IES2 (IEC 61800-9-2)											

Ins. Cl. 155 (F) DV155-J



Tamb: -20 - 50°C

S1 - Continuous SF1

IP 55 ENC.4

kg 6306 -ZZ 6305 -ZZ

Branch fuse max :0 A

\*This is a representative example of the actual data that will be displayed on the Nameplate for the motor combination featured in this document.

### hydrovar X Data Plate Legend

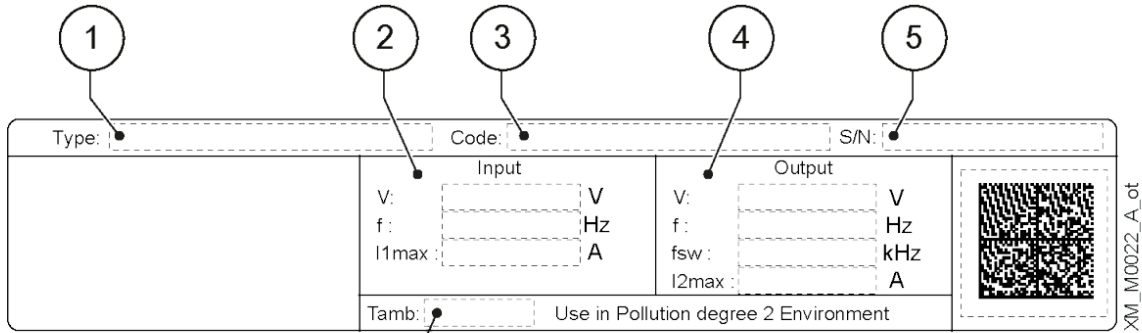

1. Model
2. Input operating limits
3. Identification code
4. Output operating limits
5. Serial number
6. Room temperature range

### hydrovar X Data Plate Information (representative) image\*

Type: 10534394-0005		Code: 130141051		S/N: 93748WIJ0000K		
XYLEM SERVICE ITALIA SRL VIA VITTORIO LOMBARDI 14, 36075 MONTECCHIO M. (VI) - ITALY Reg. No. 07520560967 MADE IN GERMANY  US E529771	<b>Input</b>		<b>Output</b>			
	V:	3 ~ 200 – 480	V	V:	0 ÷ V <sub>In</sub>	V
	f:	50 / 60	Hz	f:	0 ÷ 133	Hz
I1max:	13	A	fsw:	2 ÷ 16	kHz	
Tamb:		-20 ÷ 50°C		Use in Pollution degree 2 Environment		

\*Data Plate contains values for the motor combinations specified in this document.

**Motor Type: EXM143-145/4.020BH4**

NEMA Frame	Part Number	Weight lbs (kg)
143-145T	130635530	54 (24)
143-145TC	130635570	54 (25)
143-145JM	130635610	56 (25)
143-145JM (footed)	130637890	56 (25)

**Combined Motor and Drive Specifications**

Description	Value			
<b>Motor HP</b>	2			
<b>Enclosure</b>	TEFC			
<b>Frame Material</b>	Cast Iron/Aluminum			
<b>Nominal Voltage @ Frequency</b>	460V @ 60Hz			
<b>XP Class</b>	None			
<b>XP Division</b>	Not Applicable			
<b>Agency Approvals</b>	UL	CE		
	FCC	UKCA		
<b>Insulation Class</b>	F			
<b>Bearing Grease Type</b>	Polymer 400			
<b>Lifting Lugs</b>	Standard			
<b>Voltage</b>	380-480 V (+/- 10%)			
<b>Phase</b>	3			
<b>Input Current (380-480V)</b>	4.0-3.8 A			
<b>Power Factor</b>	0.57			
<b>Enclosure Rating</b>	IP55			
	NEMA4			
<b>Tamb</b>	-4 to +122° F			
	-20 to +50° C			
<b>DE Bearing</b>	6306-ZZ			
<b>ODE Bearing</b>	6305-ZZ			
<b>Duty Cycle</b>	S1			

**Combined Motor and Drive Performance (Nominal Voltage)<sup>1</sup>**

Rated Speed	Torque (lb.ft)	Efficiency 100%	Efficiency 75%	Efficiency 50%	Sound Pressure dB(A) <sup>2</sup>
2000 RPM	5.28	86.7	86.4	85.3	50
1800 RPM	5.87	85.1	85.9	85.6	48
1500 RPM	7.04	82.2	83.2	83.0	48

<sup>1</sup>Motor may operate below 1500 RPM at partial load. Efficiency represents PDS (power-drive-system) efficiency.

<sup>2</sup>Sound power measured at 1m distance in no-load condition according to ISO 9614-2 and sound pressure values determined according to the ISO 11203 method. Sound pressure tolerance is +/- 2 dB for all voltages.

**Drive Features and Specifications**

Description	Value
<b>Display</b>	Graphic color display
<b>Communication Protocols</b>	MODBUS® RTU BACnet MS/TP
<b>Mobile App</b>	Bluetooth®
<b>Control Modes</b>	Actuator, Constant pressure, Proportional pressure, Proportional quadratic pressure, Constant flow, Constant temperature, Constant level
<b>RS485 Ports</b>	2
<b>Analog Inputs</b>	4
<b>Analog Input Configuration</b>	0-20 mA / 4-20 mA / 0-10V / 2-10V
<b>Digital Inputs*</b>	5
<b>Analog Outputs</b>	1
<b>Analog Output Configuration</b>	0-20 mA / 4-20 mA / 0-10V / 2-10V
<b>Relay Output (Form C)*</b>	2
<b>10V Supply</b>	1
<b>Leakage Current</b>	< 3.5 mA
<b>Storage Temperature</b>	-40 to +158° F -40 to +70° C
<b>Altitude (without derating)</b>	0 to 3281 ft [0-1000 m]
<b>Humidity</b>	Max 95% non-condensing

\* See Auxiliary Connections data on the next page for more detail.

**hydrovar X with Feet**



Auxiliary Connections

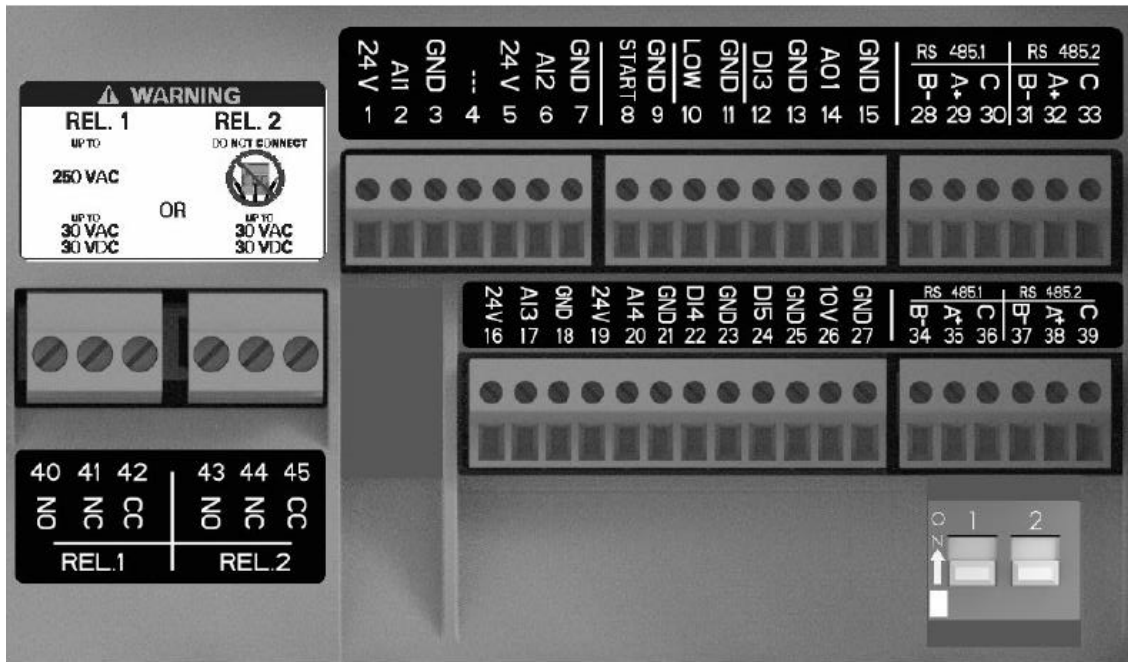

XM\_M0020\_A\_ph

Position number	Name	Description	Default setting
1	Analog input 1	Power supply +24 VDC, max. 60 mA (total, terminals 1 + 5)	Pressure sensor 1
2		Configurable Analog input 1	
3		Electronic GND	
4	Reserved	For internal use, do not connect	-
5	Analog input 2	Power supply +24 VDC, max. 60 mA (total, terminals 1 + 5)	Not selected
6		Configurable Analog input 2	
7		Electronic GND	
8	External start/stop	Digital start/stop input, internal pull-up +24 VDC, contact current 6 mA	-
9		Electronic GND	
10	External lack of water	Low water level digital input, internal pull-up +24 VDC, contact current 6 mA	-
11		Electronic GND	
12	Digital Input 3	Configurable digital input 3, internal pull-up +24 VDC, contact current 6 mA	Emergency start at maximum speed
13		Electronic GND	
14	Analog output	Configurable Analog output	Motor Speed
15		Electronic GND	
16	Analog input 3	Power supply +24 VDC, max. 60 mA (total, terminals 16 and 19)	Not selected
17		Configurable Analog input 3	
18		Electronic GND	

**Auxiliary Connections (Continued)**

Position number	Name	Description	Default Setting
19	Analog input 4	Power supply +24 VDC, max. 60 mA (total, terminals 16 and 19)	Not selected
20		Configurable Analog input 4	
21		Electronic GND	
22	Digital input 4	Configurable digital input 4, internal pull -up +24 VDC, contact current 6mA	Not selected
23		Electronic GND	
24	Digital input 5	Configurable digital input 4, internal pull -up +24 VDC, contact current 6mA	Not selected
25		Electronic GND	
26	10 VDC power supply	Power supply +10 VDC, max. 3 mA	-
27		Electronic GND	
28	Communication Bus 1	RS485 port 1: RS485-1B N (-)	Multipump
29		RS485 port 1: RS485-1A P (+)	
30		RS485 port 1: RS485-COM	
31	Communication Bus 2	RS485 port 2: RS485-2B (-)	MODBUS
32		RS485 port 2: RS485-2A P (+)	
33		RS485 port 2: RS485-COM	
34	Communication Bus 1	RS485 port 1: RS485-1B N (-)	Multipump
35		RS485 port 1: RS485-1A P (+)	
36		RS485 port 1: RS485-COM	
37	Communication Bus 2	RS485 port 2: RS485-2B N (-)	MODBUS
38		RS485 port 2: RS485-2A P (+)	
39		RS485 port 2: RS485-COM	
40	Relay 1	Configurable relay 1: normally open	Error Reporting
41		Configurable relay 1: normally closed	
42		Configurable relay 1: normally contact	
43	Relay 2	Configurable relay 2: normally open	Motor start
44		Configurable relay 2: normally closed	
45		Configurable relay 2: normally contact	



# hydrovar® X EXM143-145/4.020BH4 - 2 HP, 1200-2000 RPM, 3PH, 60HZ, 380-480V, 143-145, TEFC

## hydrovar X Smart Motor Drawings

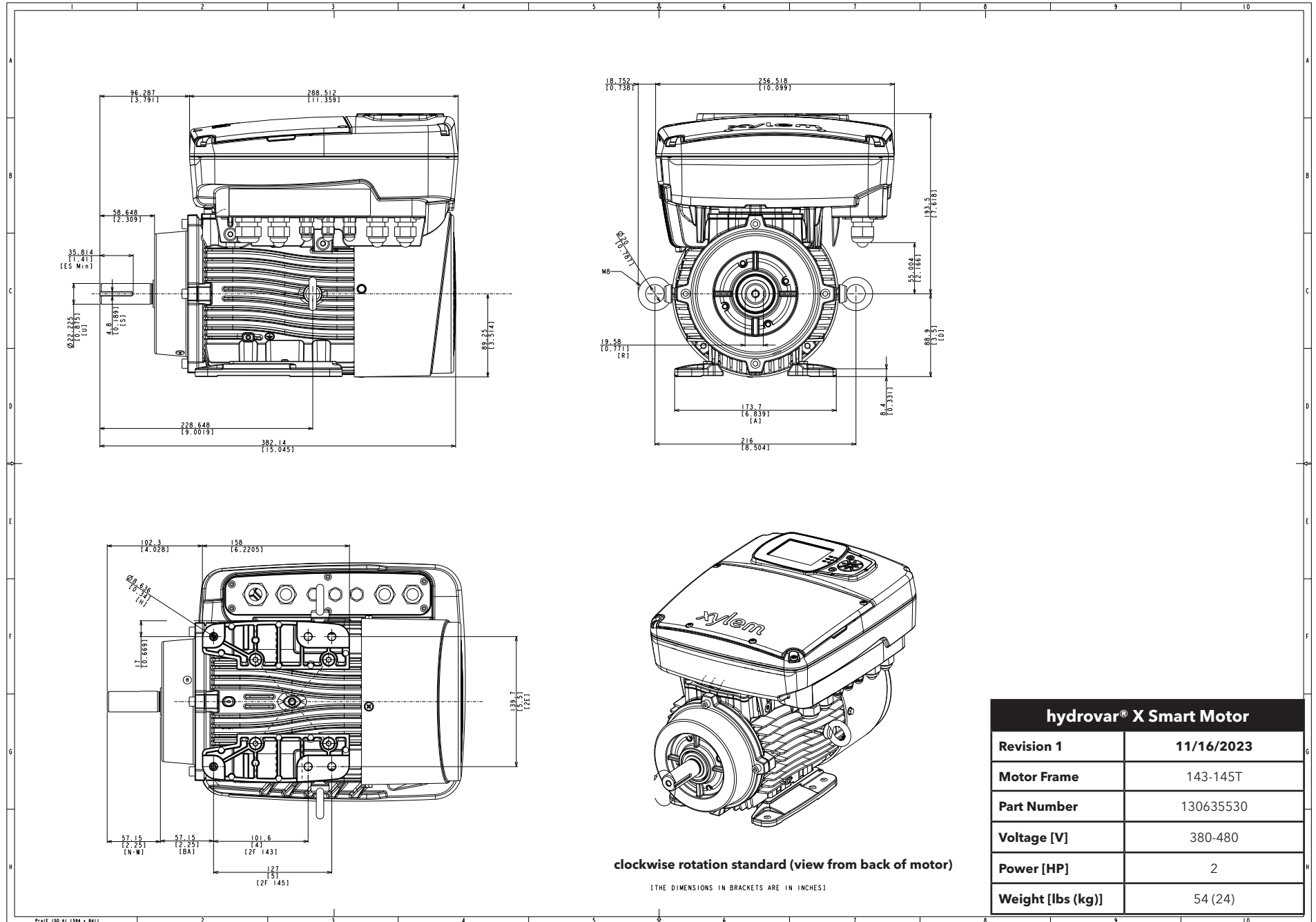



# hydrovar® X EXM143-145/4.020BH4 - 2 HP, 1200-2000 RPM, 3PH, 60HZ, 380-480V, 143-145, TEFC

## hydrovar X Smart Motor Drawings

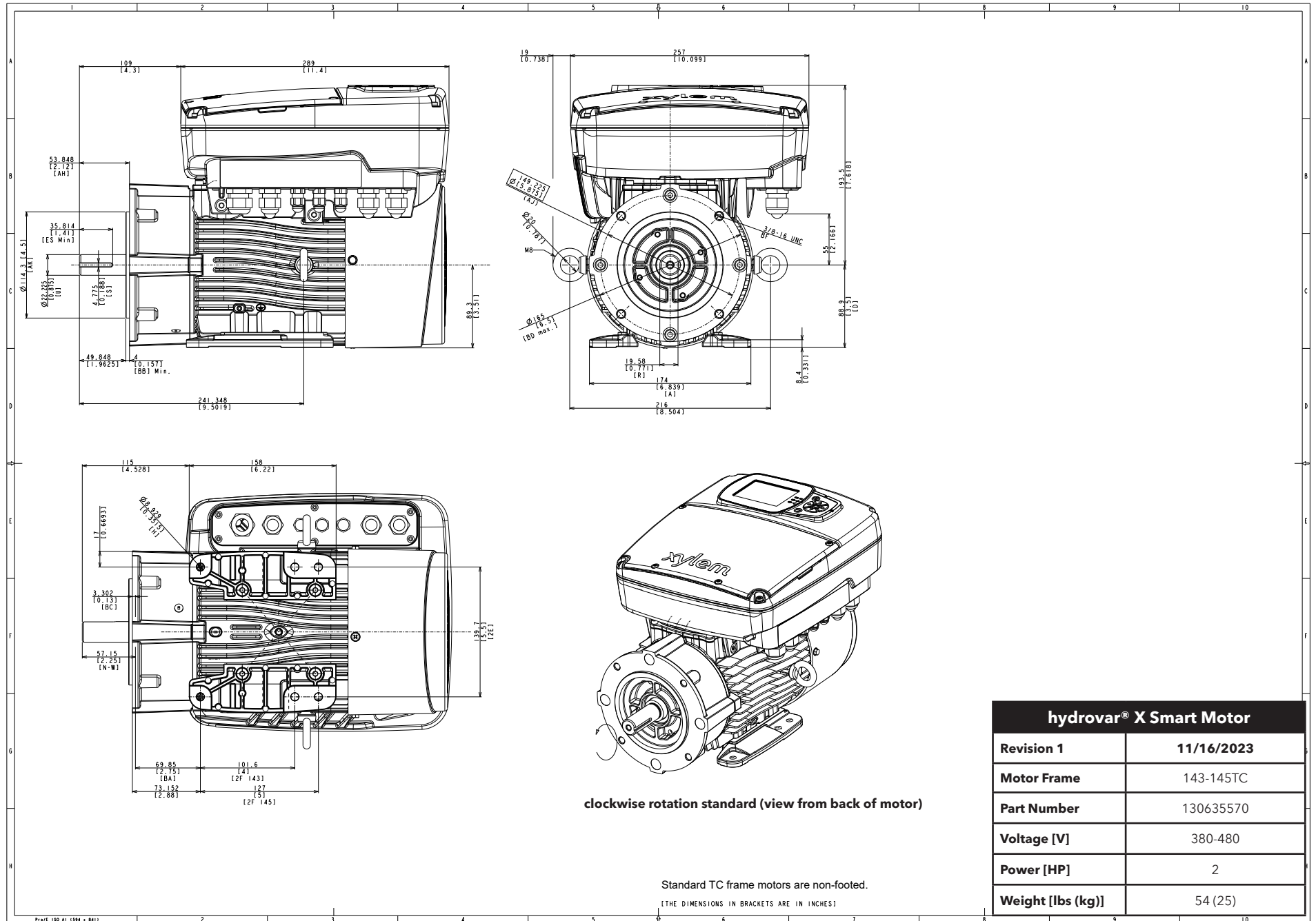

hydrovar® X Smart Motor	
Revision 1	11/16/2023
Motor Frame	143-145TC
Part Number	130635570
Voltage [V]	380-480
Power [HP]	2
Weight [lbs (kg)]	54 (25)

hydrovar X Smart Motor Drawings

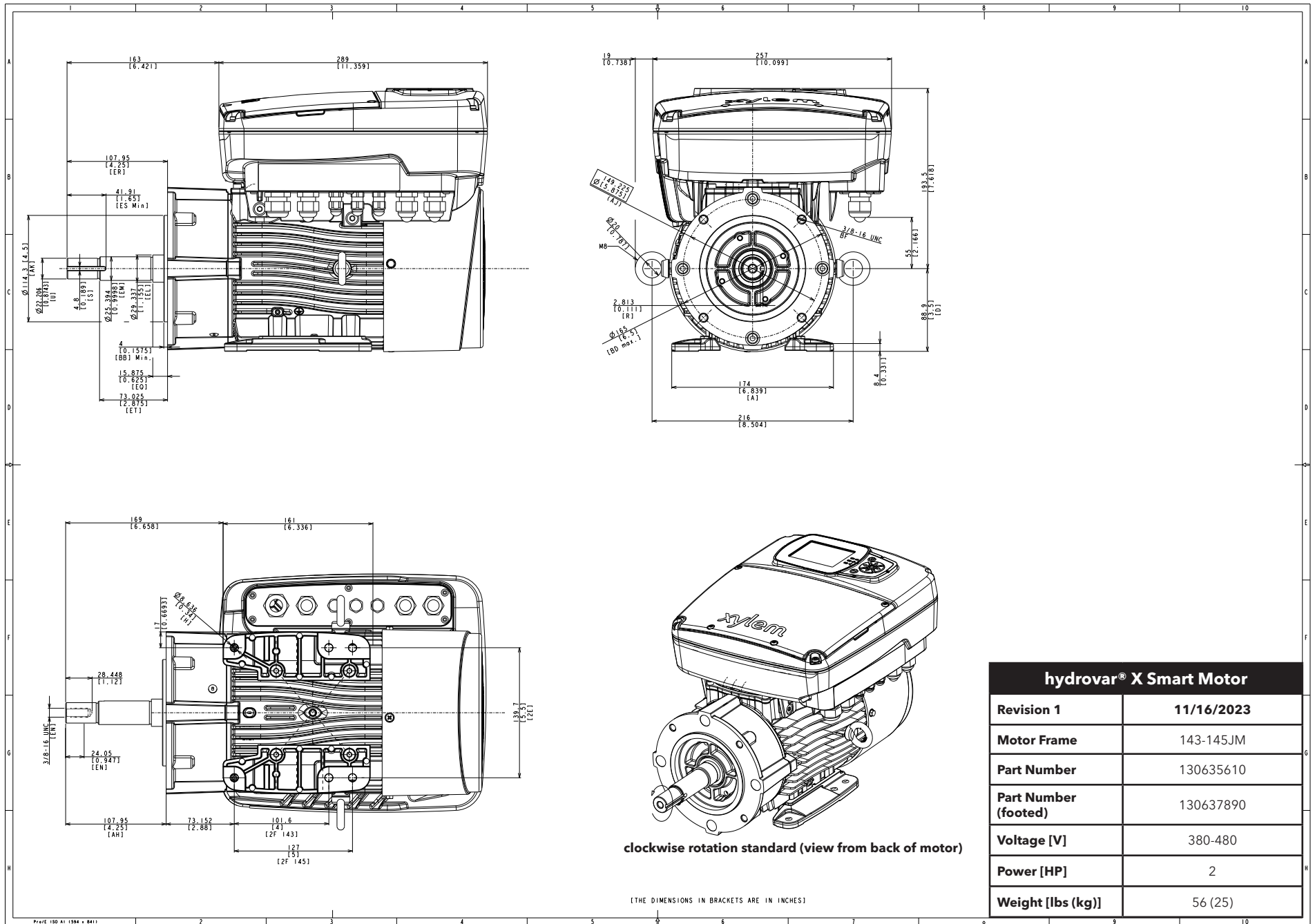

hydrovar® X Smart Motor	
Revision 1	11/16/2023
Motor Frame	143-145JM
Part Number	130635610
Part Number (footed)	130637890
Voltage [V]	380-480
Power [HP]	2
Weight [lbs (kg)]	56 (25)

**NOTES**

# Xylem |'zīləm|

- 1) The tissue in plants that brings water upward from the roots;
- 2) a leading global water technology company.

We're a global team unified in a common purpose: creating advanced technology solutions to the world's water challenges. Developing new technologies that will improve the way water is used, conserved, and re-used in the future is central to our work. Our products and services move, treat, analyze, monitor and return water to the environment, in public utility, industrial, residential and commercial building services settings. Xylem also provides a leading portfolio of smart metering, network technologies and advanced analytics solutions for water, electric and gas utilities. In more than 150 countries, we have strong, long-standing relationships with customers who know us for our powerful combination of leading product brands and applications expertise with a strong focus on developing comprehensive, sustainable solutions.

**For more information on how Xylem can help you, go to [www.xylem.com](http://www.xylem.com)**

## **Xylem Product Cybersecurity**

Xylem values your system security and the availability of your critical services. For more information on Xylem cybersecurity practices or to contact the cybersecurity team please visit [www.Xylem.com/security](http://www.Xylem.com/security).



Xylem Inc.  
Phone: (866) 673-0428  
Fax: (888) 322-5877  
[www.xylem.com](http://www.xylem.com)

Xylem reserves the right to make modification without prior notice. Xylem and Hydrovar are registered trademark of Xylem Inc. or one of its subsidiaries. MODBUS is a registered trademark of Schneider Electric USA, Inc. The Bluetooth word mark and logos are registered trademarks owned by Bluetooth SIG, Inc. and any use of such marks by Xylem Inc. or one of its subsidiaries is under license. All other trademarks or registered trademarks are property of their respective owners.