



hydrovar® X Smart Motor

Specifications

EXM254-256/3.150DH2

15 HP, 1200-4000 RPM, 3PH, 60HZ, 200-240V
254-256 Frame, TEFC

hydrovar X Nameplate Legend

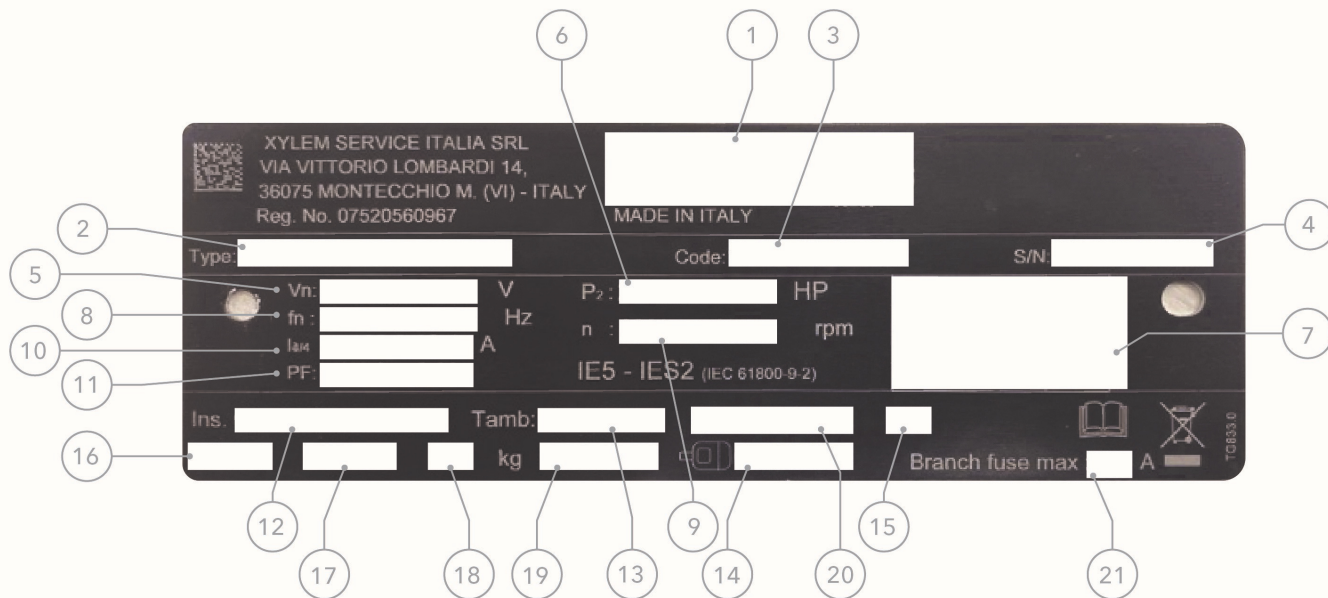

- | | |
|---|--|
| 1. Certification markings (CE, UKCA, UL Recognized) | 11. Power factor |
| 2. Motor type | 12. Insulation class |
| 3. Motor code | 13. Ambient operating temperature |
| 4. Unique motor serial number | 14. Non-drive end bearing |
| 5. Voltage range | 15. Service factor |
| 6. Output power (kW / HP) | 16. IP environmental protection rating |
| 7. Full load rated PDS efficiency (motor and drive combined efficiency) | 17. NEMA environmental protection rating |
| 8. Frequency compatibility | 18. Weight |
| 9. Full load rated speed | 19. Drive end bearing |
| 10. Full load rated current range | 20. Duty cycle rating |
| | 21. Circuit protection requirement |

hydrovar X Nameplate Information (representative example)*

XYLEM SERVICE ITALIA SRL
 VIA VITTORIO LOMBARDI 14,
 36075 MONTECCHIO M. (VI) - ITALY
 Reg. No. 07520560967

MADE IN ITALY

Type: EXM254-256/3.150DH2

Vn: 3~ 200-240 V P2: 11 kW/ 15 HP

fn: 50/60 Hz n: 3000 - 4000 rpm

I4/4: 38.4-34.1 A

PF: 0.90 IE5 - IES2 (IEC 61800-9-2)

Ins. Cl. 155 (F) DV155-J Tamb: -20 - 50°C S1 - Continuous SF1

IP 55 ENC.4 kg 6310-ZZ 6308-ZZ

Code: S/N:

PDS Eff. 230V	4/4
3000 rpm	90.3
3600 rpm	91.2
4000 rpm	91.3

Branch fuse max :0 A

*This is a representative example of the actual data that will be displayed on the Nameplate for the motor combination featured in this document.

hydrovar X Data Plate Legend

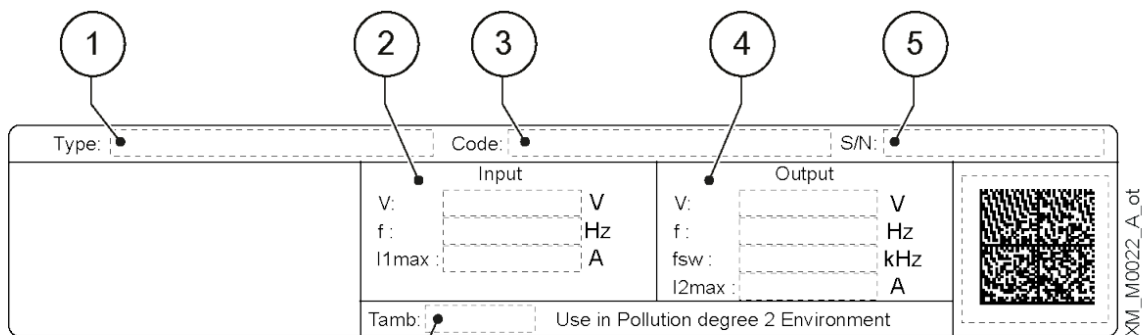

1. Model
2. Input operating limits
3. Identification code
4. Output operating limits
5. Serial number
6. Room temperature range

hydrovar X Data Plate Information (representative) image*

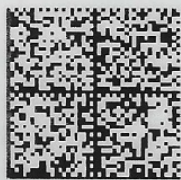
Type: 10534398-0004		Code: 130141091		S/N: 93748WIQ00004				
XYLEM SERVICE ITALIA SRL VIA VITTORIO LOMBARDI 14, 36075 MONTECCHIO M. (VI) - ITALY Reg. No. 07520560967 MADE IN GERMANY  US E529771	Input		Output					
	V:	3 ~ 200 – 480	V	V:		0 ÷ VIn	V	
	f:	50 / 60	Hz	f:		0 ÷ 133	Hz	
I1max:	50	A	fsw:	2 ÷ 8	kHz	I2max:	60	A
Tamb:		-20 ÷ 50°C		Use in Pollution degree 2 Environment				

*Data Plate contains values for the motor combinations specified in this document.

Motor Type: EXM254-256/3.150DH2

NEMA Frame	Part Number	Weight lbs (kg)
254-256T	130636771	143 (65)
254-256TC	130636811	148 (67)
254-256JM	130637771	148 (67)
254-256JM (footed)	130636851	148 (67)

Combined Motor and Drive Specifications

Description	Value			
Motor HP	15			
Enclosure	TEFC			
Frame Material	Cast Iron/Aluminum			
Nominal Voltage @ Frequency	230V @ 60Hz			
XP Class	None			
XP Division	Not Applicable			
Agency Approvals	UL	CE		
	FCC	UKCA		
Insulation Class	F			
Bearing Grease Type	Polymer 400			
Lifting Lugs	Standard			
Voltage	200-240 V (+/- 10%)			
Phase	3			
Input Current (200-240V)	38.4-34.1 A			
Power Factor	0.90			
Enclosure Rating	IP55			
	NEMA4			
Tamb	-4 to +122° F			
	-20 to +50° C			
DE Bearing	6310-ZZ			
ODE Bearing	6308-ZZ			
Duty Cycle	S1			

Combined Motor and Drive Performance (Nominal Voltage)¹

Rated Speed	Torque (lb.ft)	Efficiency 100%	Efficiency 75%	Efficiency 50%	Sound Pressure dB(A) ²
4000 RPM	19.37	91.3	90.6	89.3	75
3600 RPM	21.52	91.2	90.8	89.7	68
3000 RPM	25.82	90.3	90.3	89.4	64

¹Motor may operate below 3000 RPM at partial load. Efficiency represents PDS (power-drive-system) efficiency.

²Sound power measured at 1m distance in no-load condition according to ISO 9614-2 and sound pressure values determined according to the ISO 11203 method. Sound pressure tolerance is +/- 2 dB for all voltages.

Drive Features and Specifications

Description	Value
Display	Graphic color display
Communication Protocols	MODBUS® RTU BACnet MS/TP
Mobile App	Bluetooth®
Control Modes	Actuator, Constant pressure, Proportional pressure, Proportional quadratic pressure, Constant flow, Constant temperature, Constant level
RS485 Ports	2
Analog Inputs	4
Analog Input Configuration	0-20 mA / 4-20 mA / 0-10V / 2-10V
Digital Inputs*	5
Analog Outputs	1
Analog Output Configuration	0-20 mA / 4-20 mA / 0-10V / 2-10V
Relay Output (Form C)*	2
10V Supply	1
Leakage Current	< 3.5 mA
Storage Temperature	-40 to +158° F -40 to +70° C
Altitude (without derating)	0 to 3281 ft [0-1000 m]
Humidity	Max 95% non-condensing

* See Auxiliary Connections data on the next page for more detail.

hydrovar X with Feet



Auxiliary Connections

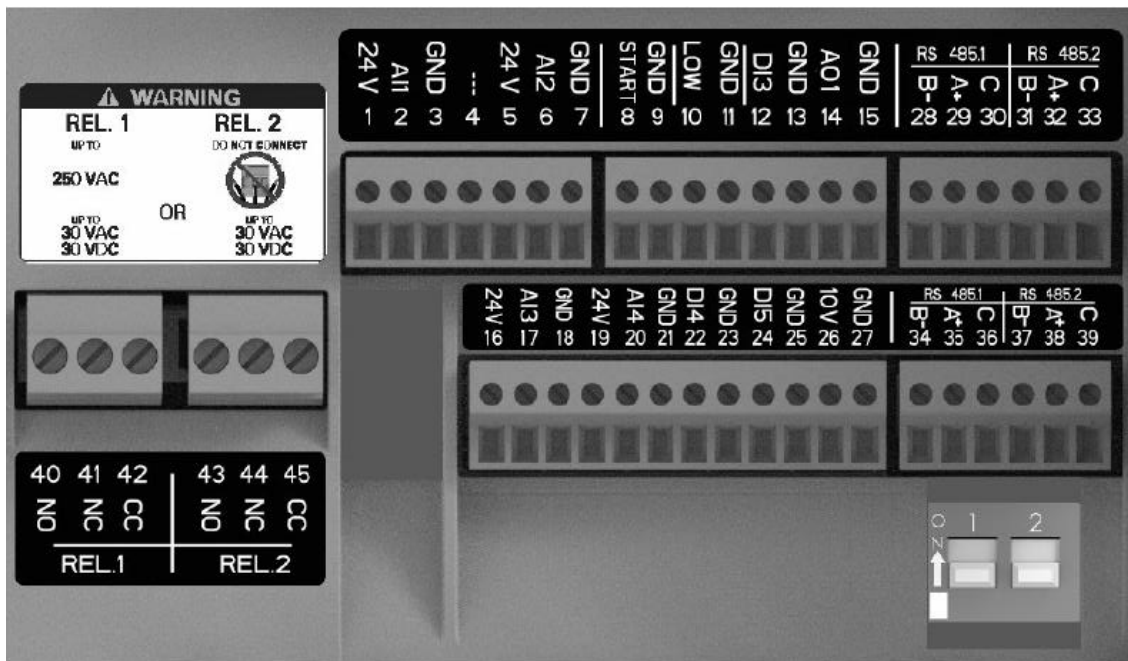

XM_M0020_A_ph

Position number	Name	Description	Default setting
1	Analog input 1	Power supply +24 VDC, max. 60 mA (total, terminals 1 + 5)	Pressure sensor 1
2		Configurable Analog input 1	
3		Electronic GND	
4	Reserved	For internal use, do not connect	-
5	Analog input 2	Power supply +24 VDC, max. 60 mA (total, terminals 1 + 5)	Not selected
6		Configurable Analog input 2	
7		Electronic GND	
8	External start/stop	Digital start/stop input, internal pull-up +24 VDC, contact current 6 mA	-
9		Electronic GND	
10	External lack of water	Low water level digital input, internal pull-up +24 VDC, contact current 6 mA	-
11		Electronic GND	
12	Digital Input 3	Configurable digital input 3, internal pull-up +24 VDC, contact current 6 mA	Emergency start at maximum speed
13		Electronic GND	
14	Analog output	Configurable Analog output	Motor Speed
15		Electronic GND	
16	Analog input 3	Power supply +24 VDC, max. 60 mA (total, terminals 16 and 19)	Not selected
17		Configurable Analog input 3	
18		Electronic GND	

Auxiliary Connections (Continued)

Position number	Name	Description	Default Setting
19	Analog input 4	Power supply +24 VDC, max. 60 mA (total, terminals 16 and 19)	Not selected
20		Configurable Analog input 4	
21		Electronic GND	
22	Digital input 4	Configurable digital input 4, internal pull -up +24 VDC, contact current 6mA	Not selected
23		Electronic GND	
24	Digital input 5	Configurable digital input 4, internal pull -up +24 VDC, contact current 6mA	Not selected
25		Electronic GND	
26	10 VDC power supply	Power supply +10 VDC, max. 3 mA	-
27		Electronic GND	
28	Communication Bus 1	RS485 port 1: RS485-1B N (-)	Multipump
29		RS485 port 1: RS485-1A P (+)	
30		RS485 port 1: RS485-COM	
31	Communication Bus 2	RS485 port 2: RS485-2B (-)	MODBUS
32		RS485 port 2: RS485-2A P (+)	
33		RS485 port 2: RS485-COM	
34	Communication Bus 1	RS485 port 1: RS485-1B N (-)	Multipump
35		RS485 port 1: RS485-1A P (+)	
36		RS485 port 1: RS485-COM	
37	Communication Bus 2	RS485 port 2: RS485-2B N (-)	MODBUS
38		RS485 port 2: RS485-2A P (+)	
39		RS485 port 2: RS485-COM	
40	Relay 1	Configurable relay 1: normally open	Error Reporting
41		Configurable relay 1: normally closed	
42		Configurable relay 1: normally contact	
43	Relay 2	Configurable relay 2: normally open	Motor start
44		Configurable relay 2: normally closed	
45		Configurable relay 2: normally contact	

hydrovar X Smart Motor Drawings

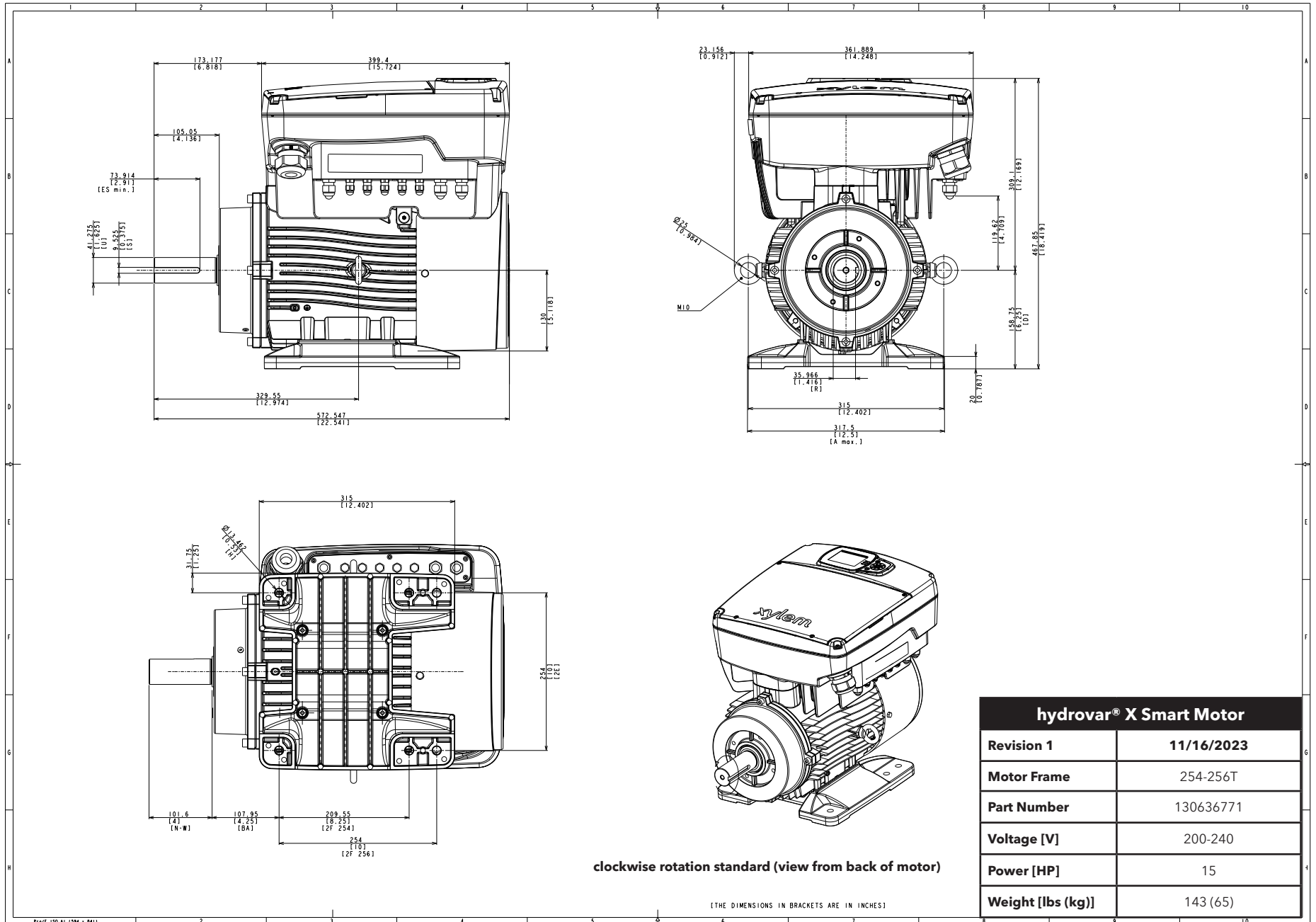

hydrovar® X EXM254-256/3.150DH2 - 15 HP, 1200-4000 RPM, 3PH, 60HZ, 200-240V, 254-256, TEFC

hydrovar X Smart Motor Drawings

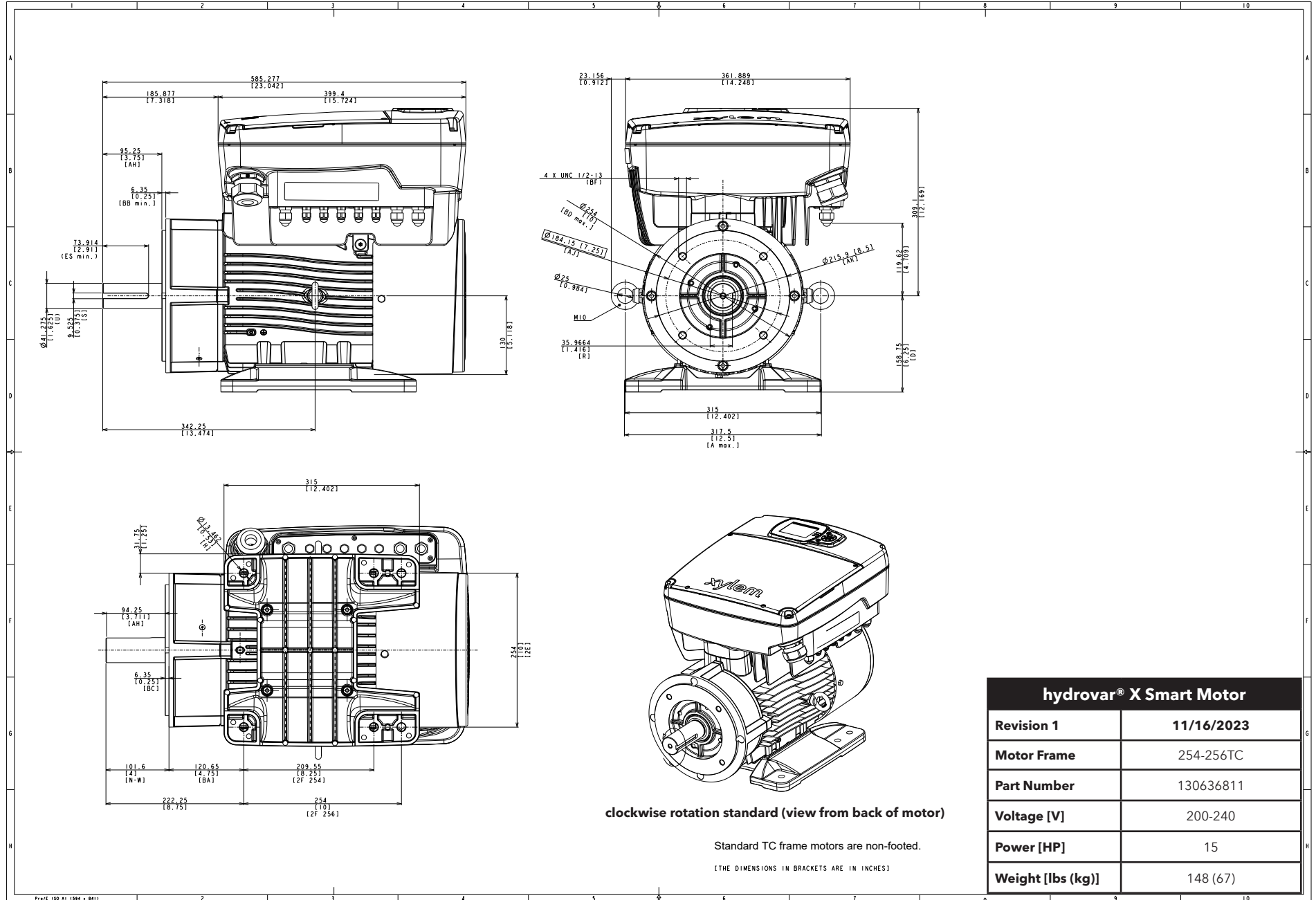

hydrovar X Smart Motor Drawings

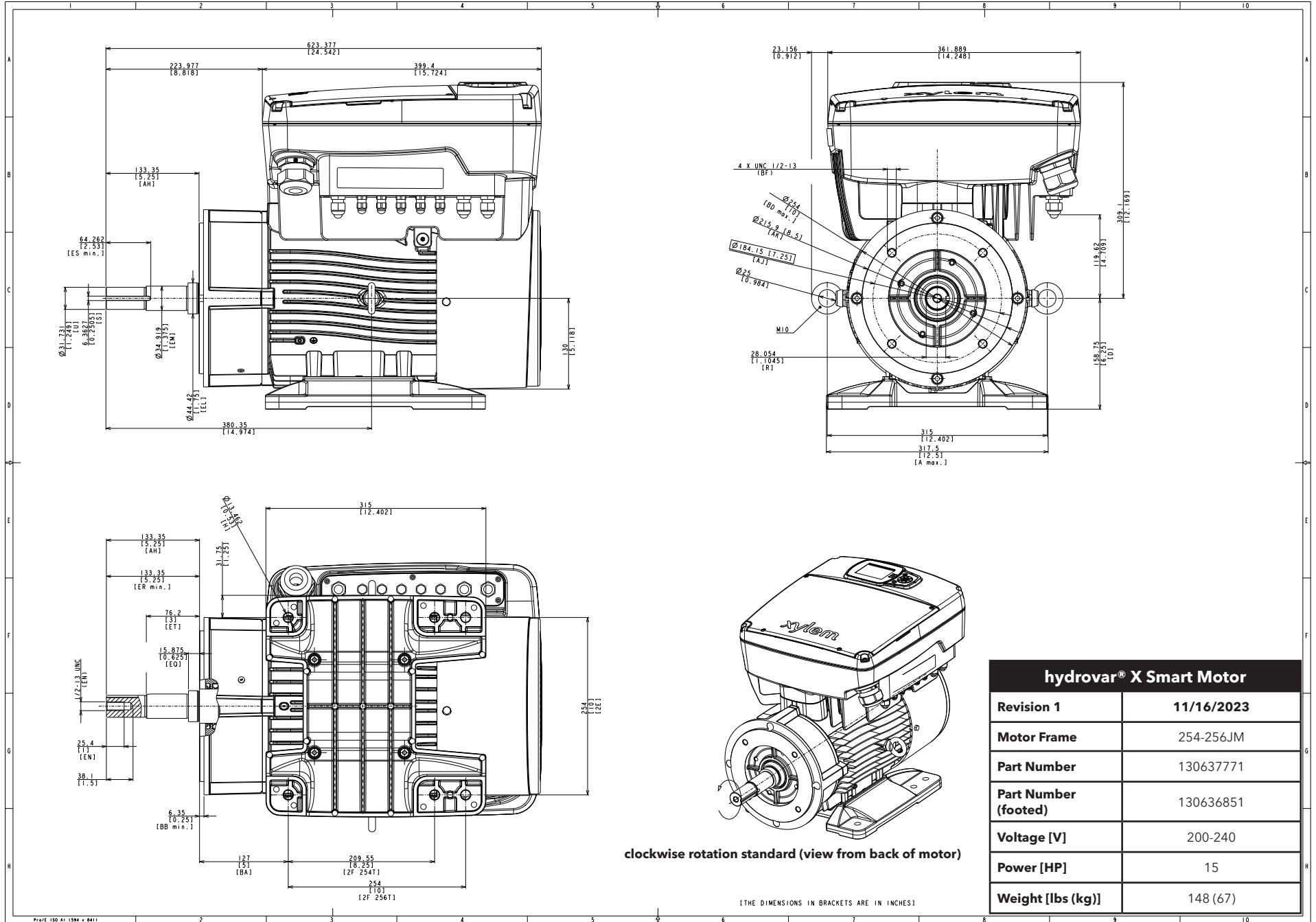

hydrovar® X Smart Motor	
Revision 1	11/16/2023
Motor Frame	254-256JM
Part Number	130637771
Part Number (footed)	130636851
Voltage [V]	200-240
Power [HP]	15
Weight [lbs (kg)]	148 (67)

NOTES

Xylem |'zīləm|

- 1) The tissue in plants that brings water upward from the roots;
- 2) a leading global water technology company.

We're a global team unified in a common purpose: creating advanced technology solutions to the world's water challenges. Developing new technologies that will improve the way water is used, conserved, and re-used in the future is central to our work. Our products and services move, treat, analyze, monitor and return water to the environment, in public utility, industrial, residential and commercial building services settings. Xylem also provides a leading portfolio of smart metering, network technologies and advanced analytics solutions for water, electric and gas utilities. In more than 150 countries, we have strong, long-standing relationships with customers who know us for our powerful combination of leading product brands and applications expertise with a strong focus on developing comprehensive, sustainable solutions.

For more information on how Xylem can help you, go to www.xylem.com

Xylem Product Cybersecurity

Xylem values your system security and the availability of your critical services. For more information on Xylem cybersecurity practices or to contact the cybersecurity team please visit www.Xylem.com/security.



Xylem Inc.
Phone: (866) 673-0428
Fax: (888) 322-5877
www.xylem.com

Xylem reserves the right to make modification without prior notice. Xylem and Hydrovar are registered trademark of Xylem Inc. or one of its subsidiaries. MODBUS is a registered trademark of Schneider Electric USA, Inc. The Bluetooth word mark and logos are registered trademarks owned by Bluetooth SIG, Inc. and any use of such marks by Xylem Inc. or one of its subsidiaries is under license. All other trademarks or registered trademarks are property of their respective owners.