



eco2

OUTSTANDING ENERGY EFFICIENT AND CUSTOMIZABLE CIRCULATORS
FOR ORIGINAL EQUIPMENT MANUFACTURERS.

A partner, more than a product.

Best-in-class energy efficiency

The high efficiency ECM motor and optimized hydraulic keeps operational costs at minimum. EEI level ≤ 0.18 .

Automatic Air-Purge

The automatic air-purge mode supports the proper air venting of the system.

Broad application range

The multiple pump-housing options make the circulator flexible to meet various OEM customer needs.



A2L certified

The circulation pump is designed to work safely with low-flammability refrigerants, contributing to compliance with safety standards and environmental regulations.

Multiple connection

Power and communication connections are available in several standard configurations.

Meet eco2 from Xylem. Make it your partner in heating, cooling and solar applications, from one of the largest global suppliers in the water industry. Best-in-class energy efficiency, lasting quality with service levels that ensure maximum flexibility and value. Let's solve water together.

User-friendly and accessible HMI

The Human Machine Interface is accessible directly from the front. It's easy to set-up and operates with "just one turn" of the multifunctional multicolour LED knob (eco2).

Easy access to the pump head screws

The circulator is designed to allow easy access to the pump head screws directly from the front.



Easy connection

Easy access to the connections from the front the circulator.

Operating flexibility

The circulator is available with standard operating modes (fixed, variable and constant pressure), all externally driven by PWM signal.

Product customization and co-development.

Cables

Cable length for power and communication.

Private label

Includes installation and operational manual.

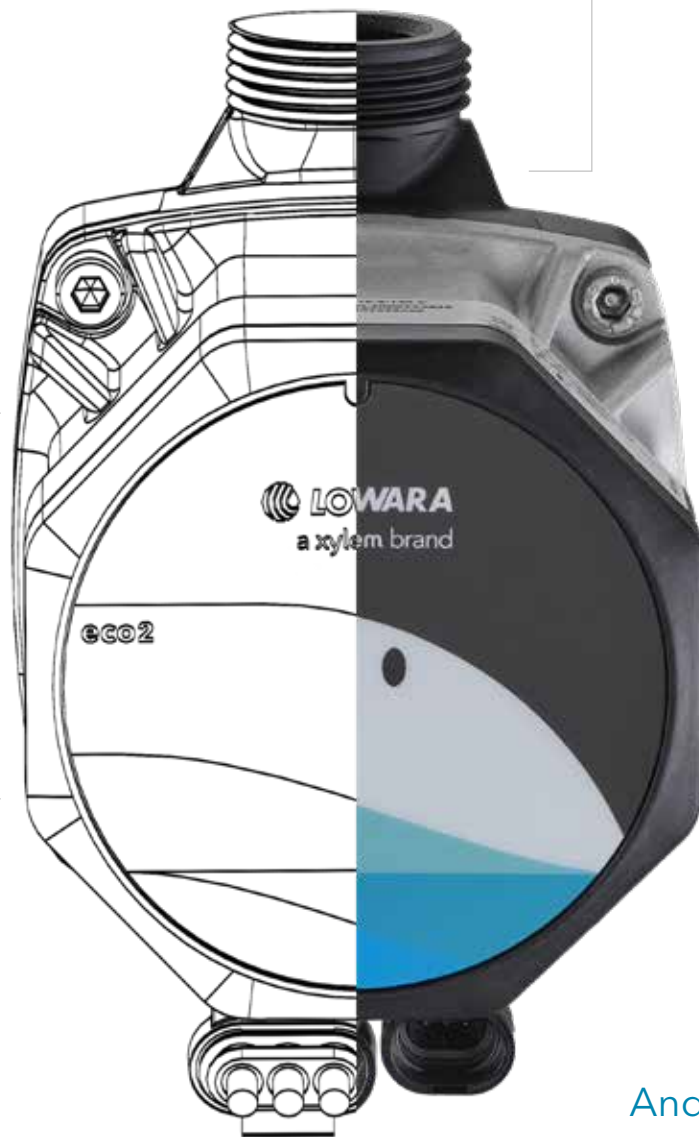

Packaging

Bulk packaging with customizable options.

And more

Additional options: Insulation shell, adapters.

Meet eco2: A highly efficient circulator for OEM applications that is engineered for optimal fluid transfer capabilities and reliable operation. It provides moderate to high flow rates with low energy consumption and long-life cycles. eco2 is specifically designed for building services in the OEM market but can also be used for other applications. Designed to meet customer-specific criteria, these units feature adjustable speeds allowing them to operate optimally at different temperatures and pressures. Additionally, they are available in a range of pump house materials such as cast iron, composite and stainless steel to resist corrosion as well as integrated protection systems providing guaranteed against any potential damage.

Applications:



Heating and Cooling Systems

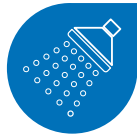

Domestic Hot Water System

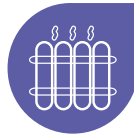

System with Thermostatic Radiator Valves



Underfloor Heating System



Thermal Solar System



eco2

Highly efficient circulation pump for heating, cooling and domestic hot water applications, with a wide range of performance and flexibility in its design.



Product Features:

- Flow rate: up to 4,5 m3/h
- Head: up to 8 m
- Maximum Power Consumption: 55 W
- Automatic Air-purge
- Pump housings: cast iron, stainless steel, composite
- Operating Modes: proportional pressure, constant pressure, constant speed, 2 ways PWM
- Power connection: cable gland, Superseal plug
- Human Machine Interface: multifunctional knob to set up all pump functionalities; 1 LED to read pump status
- A2L certified according to EU Legislation EN 60335-2-40:2022 industry standards

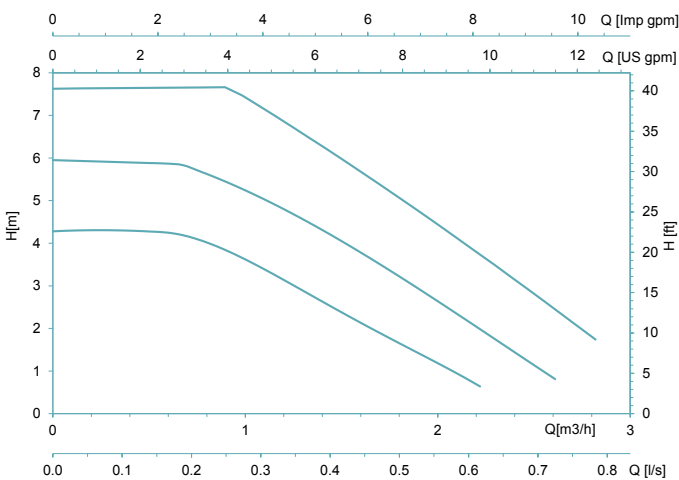
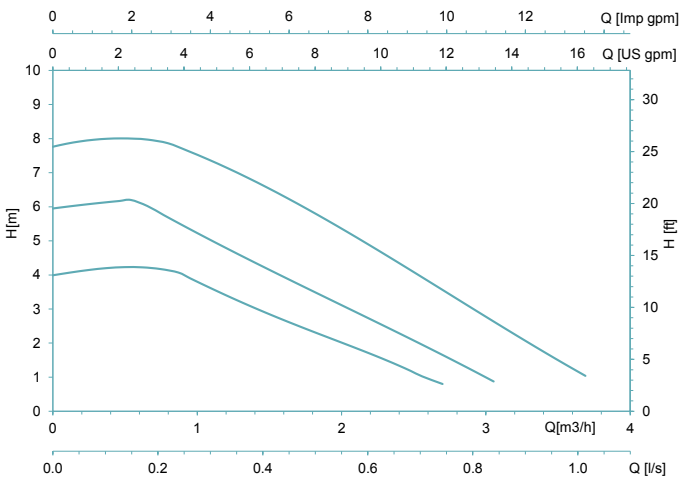

Composite version

eco2 Solar

The high-performance circulator series is designed for solar thermal applications. With a head up to 15m wide, high static pressure and wide temperature range, makes this version the best fit for this application.

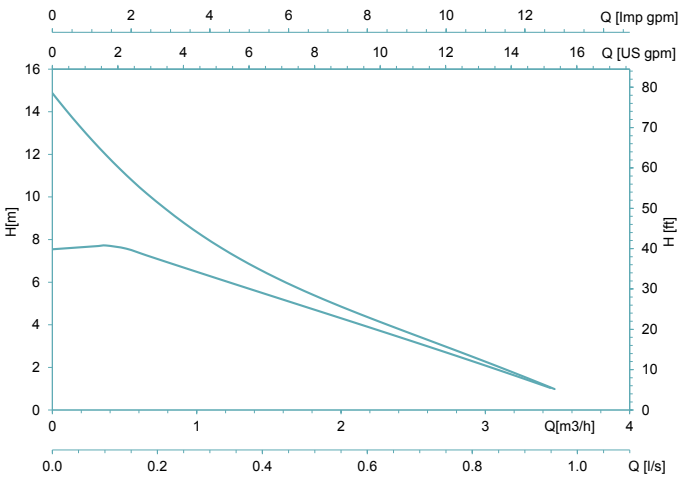

Product Features:

- Flow rate: up to 4,5 m³/h
- Head: up to 15 m
- Maximum Power Consumption: 52 W
- Automatic Air-purge
- Pump housings: cast iron
- Operating Modes: proportional pressure, constant pressure, constant speed, 2 ways PWM
- Power connection: cable gland, Superseal plug
- Human Machine Interface: multifunctional knob to set up all pump functionalities; 1 LED to read pump status
- A2L certified according to EU Legislation EN 60335-2-40:2022 industry standards

eco2 Microflow

Microflow - the most efficient solution for the widest range of tap flow (1:10 of minimum and maximum flow) specially designed for freshwater modules.

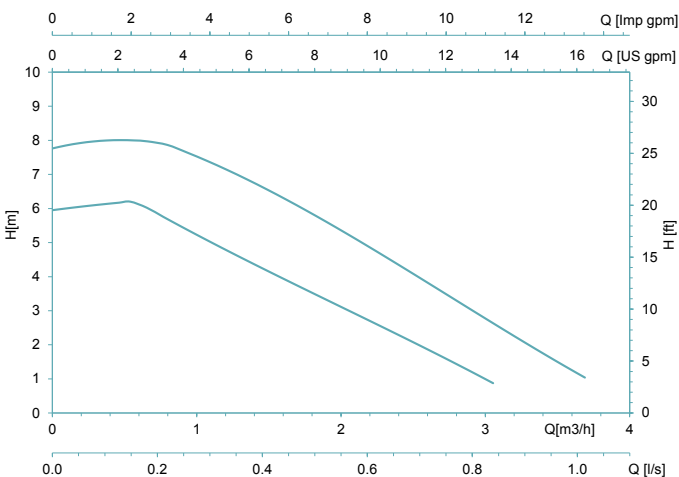

Product Features:

- Flow rate: up to 4,5 m³/h
- Head: up to 8 m
- Maximum Power Consumption: 55 W
- Automatic Air-purge
- Pump housings: cast iron
- Communication protocol: PWM
- Power connection: cable gland, Superseal plug
- Human Machine Interface: 1 LED to read pump status
- A2L certified according to EU Legislation EN 60335-2-40:2022 industry standards

Xylem |'zīləm|

- 1) The tissue in plants that brings water upward from the roots;
- 2) a leading global water technology company.

We're a global team unified in a common purpose: creating advanced technology solutions to the world's water challenges. Developing new technologies that will improve the way water is used, conserved, and re-used in the future is central to our work. Our products and services move, treat, analyze, monitor and return water to the environment, in public utility, industrial, residential and commercial building services settings. Xylem also provides a leading portfolio of smart metering, network technologies and advanced analytics solutions for water, electric and gas utilities. In more than 150 countries, we have strong, long-standing relationships with customers who know us for our powerful combination of leading product brands and applications expertise with a strong focus on developing comprehensive, sustainable solutions.

For more information on how Xylem can help you, go to www.xylem.com

