



# 5" - 11" Pre-Engineered Submersible Turbine Pumps

FOR 6" AND LARGER WELLS

### FEATURES

**Discharge Bowl:** Several discharge sizes available (NPT).

**Discharge Bearing:** Extra long sealed top bronze bearing insures shaft alignment and stabilization for extended life.

**Intermediate Bowl:** Class 30 cast iron. Glass coating on 6" and larger bowls for maximum efficiency and abrasion resistance.

**Impellers:** Designed for maximum efficiency with a wide range hydraulic coverage. Made of low zinc and no lead material suitable for drinking water applications.

**Taperlock:** Accurately machined to ensure positive locking of the impeller to the pump shaft.

**Upthrust Collar:** Designed with extra margin of safety against momentary upthrust at start-up.

**Suction Adapter:** Designed to ensure proper pump/motor alignment. Open area permits easy access to pump/motor coupling. Casting made of ductile iron for increased strength.

**Pump to Motor Coupling:** Stainless steel coupling accurately machined for perfect alignment, balance and power transmission.

**Pump Shaft:** 100,000 PSI high tensile type 416 stainless steel provides strength and corrosion resistance. Ground and polished for smooth bearing surface.

**Powered for Continuous Operation:** All horsepower ratings are within the service limits of the motor and pump can be operated continuously without fear of damage to the motor.

#### Goulds Water Technology Motors:

- Corrosion-resistant construction
- Stainless steel splined shaft
- Hermetically sealed windings on 6" motors. 8" and 10" motors are water tight rewindable.
- Sand resistant slinger and lip seals
- Water filled design
- Filter check valve
- Kingsbury-type thrust bearing
- 6 through 30 HP motors are dual voltage (230/460) design. Easily changed with a voltage plug.

### SPECIFICATIONS & NOMENCLATURE

Model	Operating Range (GPM)	Best Efficiency Flow (GPM)	Horsepower Range	Discharge Connections	Minimum Well Size <sup>1</sup>
5RWALC	37 - 123	80	7.5 - 30	4"	6"
5RWAHC	48 - 136	97	7.5 - 40	4"	6"
5CLC	51 - 173	117	7.5 - 40	4"	6"
5CHC	73 - 225	155	7.5 - 50	4"	6"
5TLC	80 - 270	175	5 - 40	4"	6"
5THC	126 - 375	243	7.5 - 60	4"	6"
6CLC	83 - 240	190	7.5 - 50	4"	8"
6CHC	107 - 331	230	15 - 60	4"	8"
7WALC	108 - 310	224	7.5 - 60	6"	8"
7WAHC	120 - 340	270	15 - 100	6"	8"
7CLC	166 - 496	375	15 - 125	6"	8"
7CHC	165 - 497	448	25 - 150	6"	8"
7TLC	241 - 690	540	15 - 100	6"	8"
7THC	327 - 870	700	20 - 150	6"	8"
8RJLC	201 - 623	487	15 - 125	6"	10"
8RJHC	495 - 918	647	20 - 150	6"	10"
9WALC	166 - 586	370	20 - 125	6"	10"
9WAHC	219 - 627	490	30 - 150	6"	10"
9RCLC	356 - 1111	858	40 - 175	6"	10"
9RCHC	443 - 1325	1033	60 - 250	6"	10"
9TLC	571 - 1628	1156	50 - 250	6"	10"
9THC	681 - 1943	1526	75 - 300	6"	10"
10WALC	285 - 818	585	40 - 150	6"	12"
10WAHC	369 - 1031	721	60 - 250	6"	12"
11CLC	574 - 1758	1228	100 - 300	8"	12"

**Notes:** Minimum well size is relevant for the bowl assembly only. Be aware some pumps allow configurations with motors that exceed the listed minimum well size.

### NOMENCLATURE DESCRIPTION

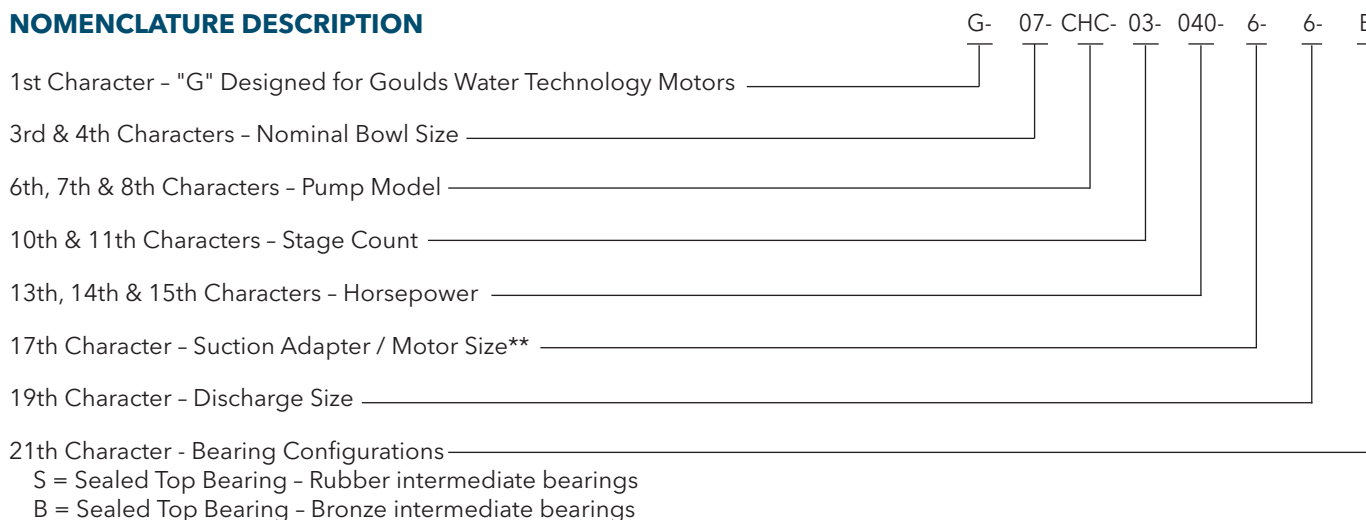

\*\* "0" designates a 10" motor size

All products in this bulletin are NSF Certified

Performance illustrated is based on Goulds Water Technology motors

Other motor brands are available, consult factory for performance

## 2 POLE (3600 RPM) PERFORMANCE CHART

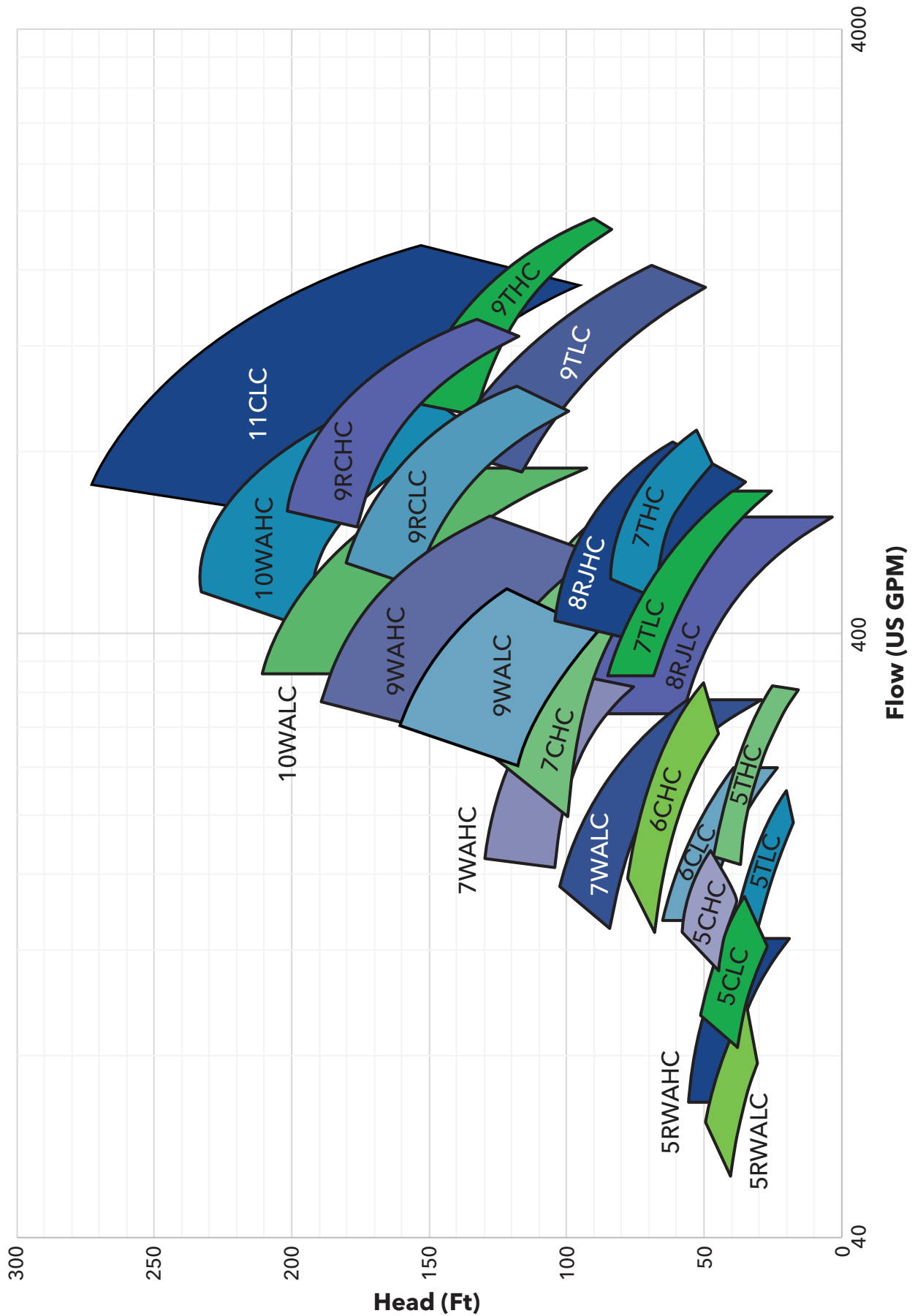

## Turbine

Part Name	Xylem Material Code	Material Description	ASTM Code
Shaft	2227	416SS	A582 S41600
Coupling	2218	416SS	A582M
Suction Adapter	1018	Ductile Iron	A536
Suction Bearing	1618	Bronze	B584 Modified
Impeller	1203	316SS	A744M
Taperlock	2242	Carbon Steel	A108
Intermediate Bowl	6911	Cast Iron Glass Enameled	A48
Intermediate Bowl Bearing	1618	Bronze	B584 Modified
Intermediate Bowl Bearing (Optional)	5121	Rubber	D2000
Upthrust Collar	6266	Polyethylene	None
Discharge Bowl	6911	Cast Iron Glass Enameled	A48
Discharge Bowl Bearing	1618	Bronze	B584 Modified
Fasteners	2298	Grade 8 Steel	J429 Gr.8
Cable Guard	3215	304SS	A240M
Suction Screen	3215	304SS	A240M

**IMPELLER MODEL: 5RWALC**

**BEP FLOW: 82 GPM**

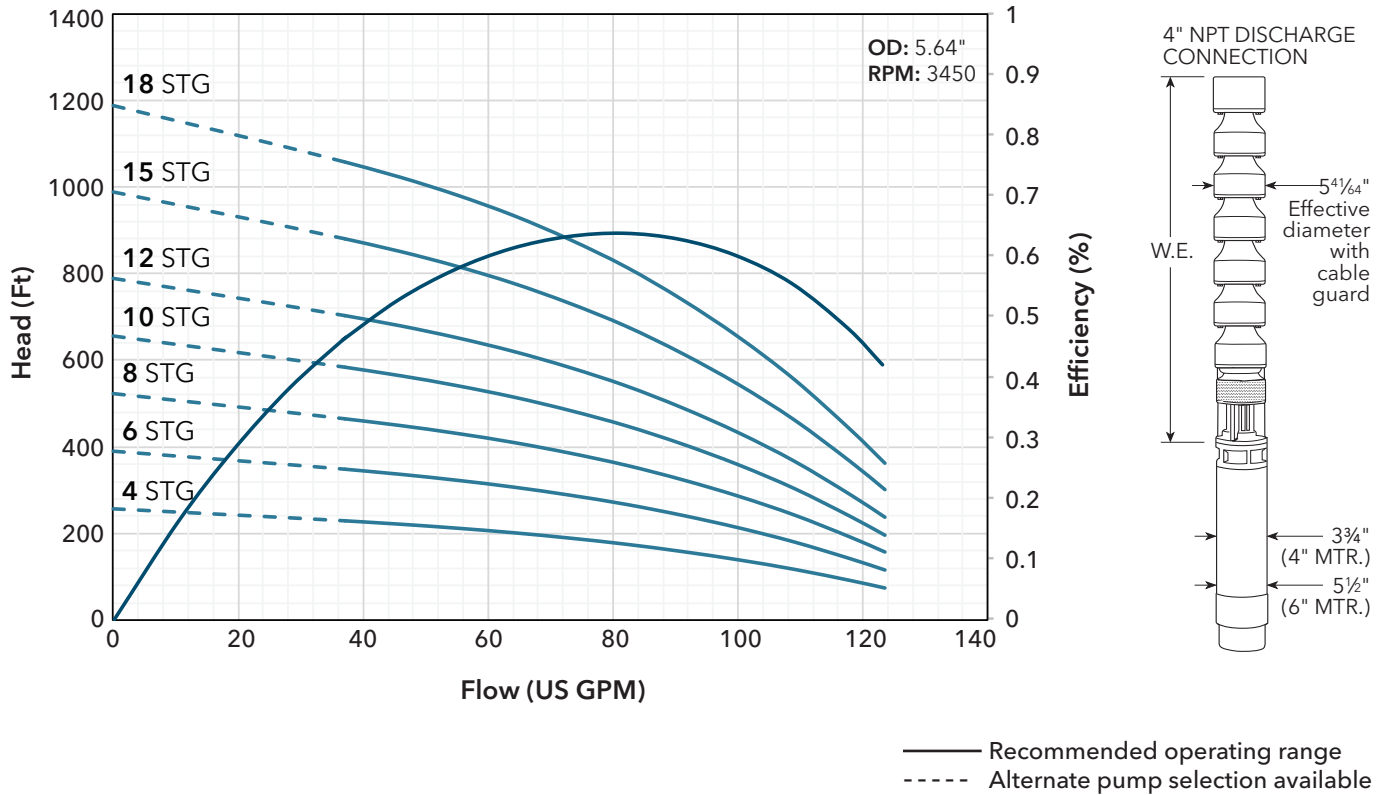

Stages	HP	W.E. Length (in)	W.E. Wt. (lbs.)	W.E. Model Number	GWT Series Motor PN# (V)				
					200	230	460	575	230/460
4	7.5	25.3	75	G-05-RWL-04-007-4-4-B	N/A	N/A	N/A	N/A	N/A
4	7.5	27.4	83	G-05-RWL-04-007-6-4-B	6F078	6F071	6F074	6F075	6F0724
6	10	33.3	100	G-05-RWL-06-010-4-4-B	N/A	N/A	N/A	N/A	N/A
6	10	35.4	108	G-05-RWL-06-010-6-4-B	6F108	6F101	6F104	6F105	6F1024
8	15	43.4	132	G-05-RWL-08-015-6-4-B	6F158	6F151	6F154	6F155	6F1524
10	15	51.4	156	G-05-RWL-10-015-6-4-B	6F158	6F151	6F154	6F155	6F1524
10	20	51.4	156	G-05-RWL-10-020-6-4-B	6F208	6F202	6F204	6F205	6F2024
12	20	59.4	179	G-05-RWL-12-020-6-4-B	6F208	6F202	6F204	6F205	6F2024
15	25	71.4	216	G-05-RWL-15-025-6-4-B	6F258	6F252	6F254	6F255	6F2524
18	30	83.4	252	G-05-RWL-18-030-6-4-B	6F308	6F302	6F304	6F305	6F3024

**NOTES:**

1. Dimensions / Weights are not for construction purposes.
2. Models are selected to be non-overloading across the duty curve, except for highlighted selections which are non-overloading at the best efficiency duty point but may overload recommended motor size towards runout. Highlighted models stay below 1.15 service factor.
3. To use pre-configured model number, no changes are allowed with the exception of impeller trim.
4. Xylem pumps can be used with multiple motor brands. If no motor is listed, another manufacturer's is likely available, consult the submersible turbine pricebook (PTURBVS) for a complete list.

**IMPELLER MODEL:** 5RWALC Trimmed

**BEP FLOW:** 73 GPM

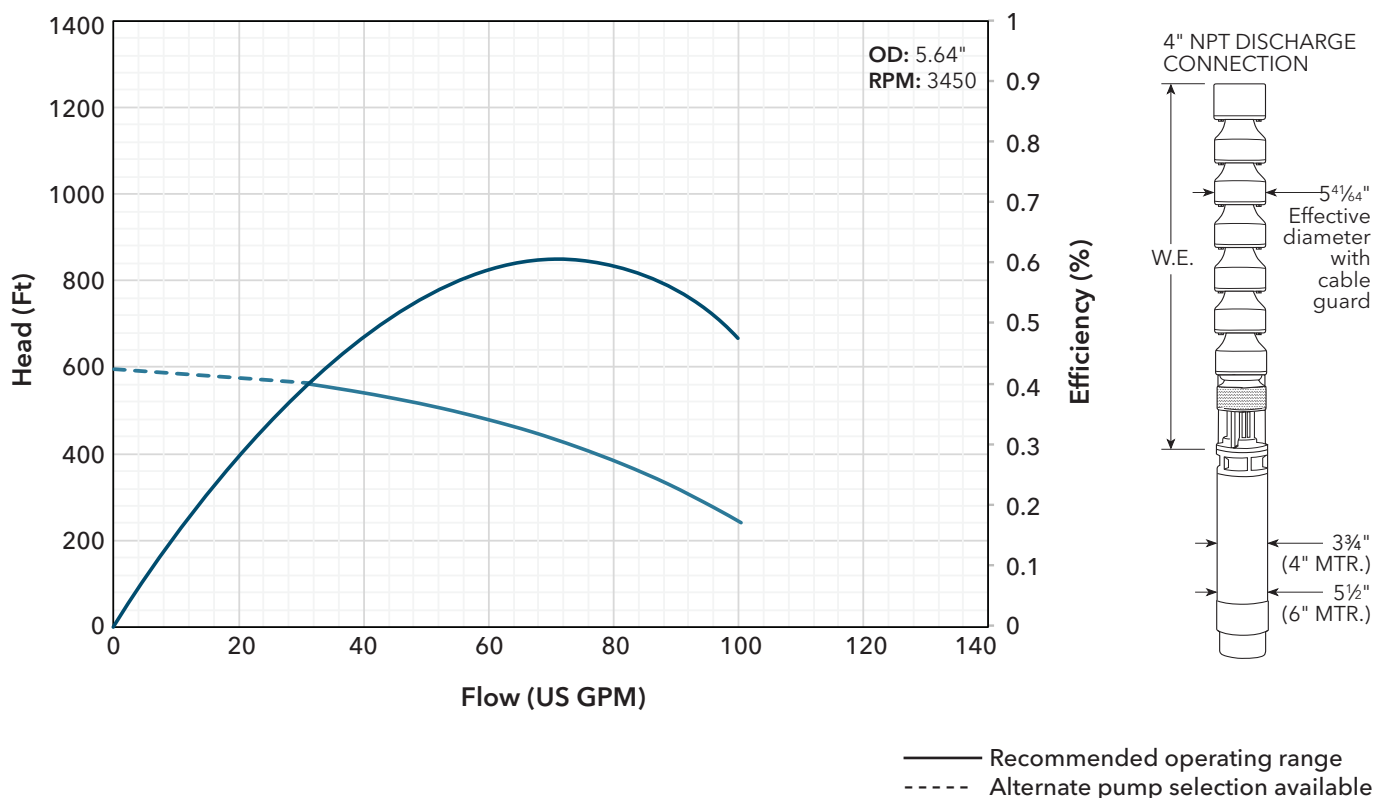

Stages	HP	W.E. Length (in)	W.E Wt. (lbs.)	W.E. Model Number	GWT Series Motor PN# (V)				
					200	230	460	575	230/460
12	15	59.4	179	G-05-RWL-12-015-6-4-B	6F158	6F152	6F154	6F155	6F1524

**NOTES:**

1. Dimensions / Weights are not for construction purposes.
2. To use pre-configured model number, no changes are allowed with the exception of impeller trim.
3. Xylem pumps can be used with multiple motor brands. If no motor is listed, another manufacturer's is likely available, consult the submersible turbine pricebook (PTURBVS) for a complete list
4. Configuration shown is equipped with trimmed impellers as standard to remain below NOL hp.

**IMPELLER MODEL: 5RWAHC**

**BEP FLOW: 97 GPM**

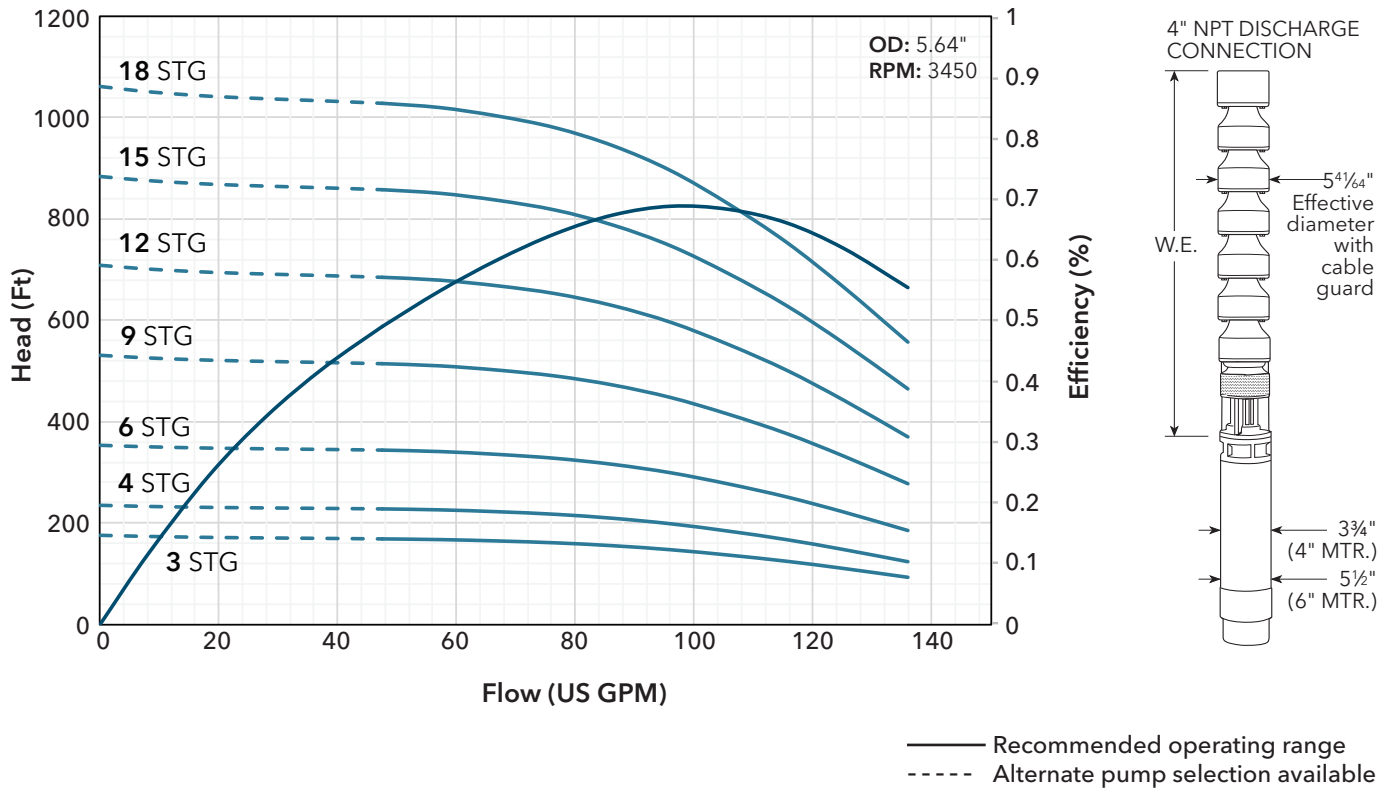

Stages	HP	W.E. Length (in)	W.E. Wt. (lbs.)	W.E. Model Number	GWT Series Motor PN# (V)				
					200	230	460	575	230/460
3	7.5	21.3	64	G-05-RWH-03-007-4-4-B	N/A	N/A	N/A	N/A	N/A
3	7.5	23.4	72	G-05-RWH-03-007-6-4-B	6F078	6F071	6F074	6F075	6F0724
4	7.5	25.3	75	G-05-RWH-04-007-4-4-B	N/A	N/A	N/A	N/A	N/A
4	10	25.3	75	G-05-RWH-04-010-4-4-B	N/A	N/A	N/A	N/A	N/A
4	7.5	27.3	83	G-05-RWH-04-007-6-4-B	6F078	6F071	6F074	6F075	6F0724
4	10	27.3	83	G-05-RWH-04-010-6-4-B	6F108	6F101	6F104	6F105	6F1024
6	15	35.4	107	G-05-RWH-06-015-6-4-B	6F158	6F151	6F154	6F155	6F1524
9	20	51.4	155	G-05-RWH-09-020-6-4-B	6F208	6F202	6F204	6F205	6F2024
12	25	59.4	177	G-05-RWH-12-025-6-4-B	6F258	6F252	6F254	6F255	6F2524
15	30	71.4	213	G-05-RWH-15-030-6-4-B	6F308	6F302	6F304	6F305	6F3024
18	40	83.4	252	G-05-RWH-18-040-6-4-B	N/A	N/A	6F404	6F405	N/A

**NOTES:**

1. Dimensions / Weights are not for construction purposes.
2. Models are selected to be non-overloading across the duty curve, except for highlighted selections which are non-overloading at the best efficiency duty point but may overload recommended motor size towards runout. Highlighted models stay below 1.15 service factor.
3. To use pre-configured model number, no changes are allowed with the exception of impeller trim.
4. Xylem pumps can be used with multiple motor brands. If no motor is listed, another manufacturer's is likely available, consult the submersible turbine pricebook (PTURBVS) for a complete list.



**IMPELLER MODEL: 5CLC**

**BEP FLOW: 117 GPM**

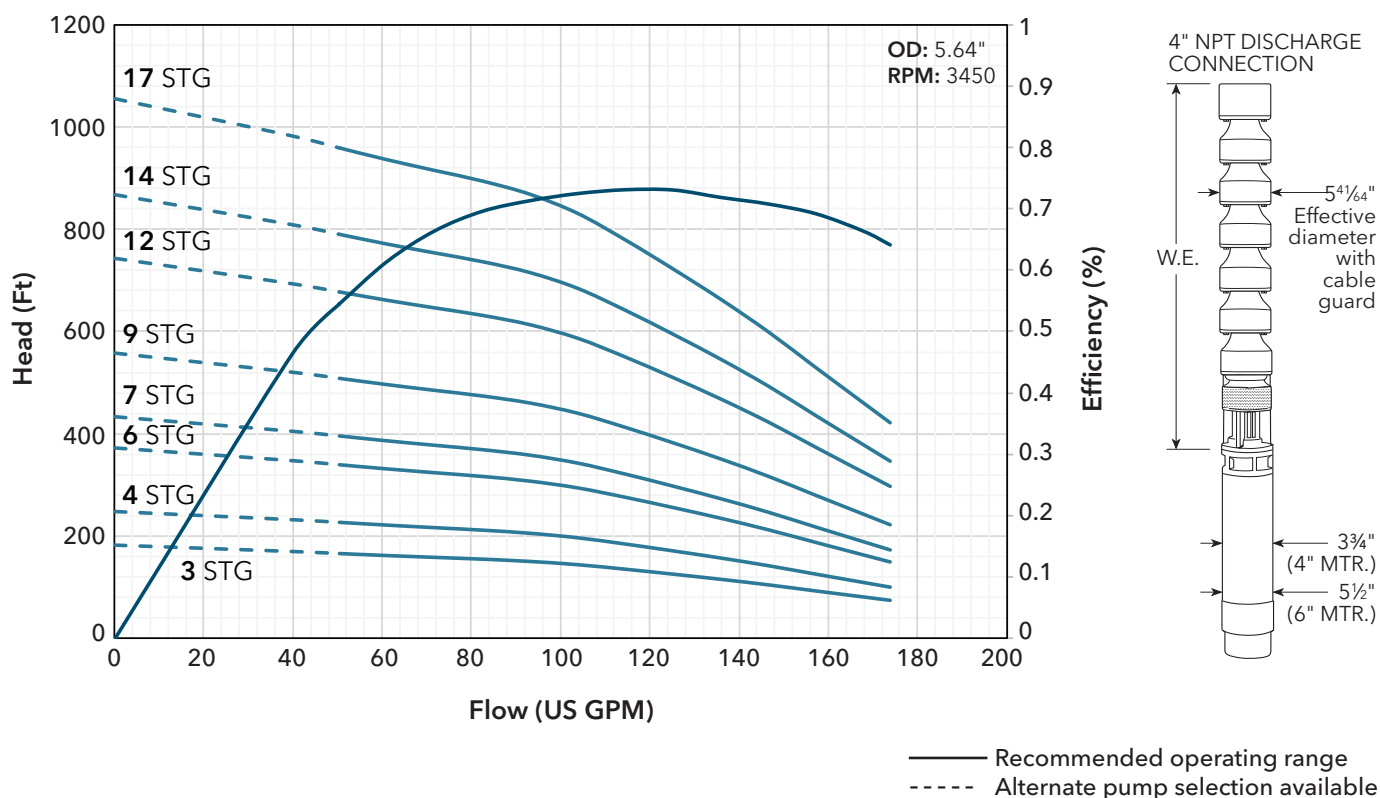

Stages	HP	W.E. Length (in)	W.E Wt. (lbs.)	W.E. Model Number	GWT Series Motor PN# (V)				
					200	230	460	575	230/460
3	7.5	25.2	70	G-05-CLC-03-007-4-4-B	N/A	N/A	N/A	N/A	N/A
3	7.5	27.5	75	G-05-CLC-03-007-6-4-B	6F078	6F071	6F074	6F075	6F0724
4	7.5	29.8	83	G-05-CLC-04-007-4-4-B	N/A	N/A	N/A	N/A	N/A
4	7.5	32.1	88	G-05-CLC-04-007-6-4-B	6F078	6F071	6F074	6F075	6F0724
6	15	41.4	114	G-05-CLC-06-015-6-4-B	6F158	6F151	6F154	6F155	6F1524
7	15	46.1	127	G-05-CLC-07-015-6-4-B	6F158	6F151	6F154	6F155	6F1524
9	20	55.3	153	G-05-CLC-09-020-6-4-B	6F208	6F202	6F204	6F205	6F2024
12	25	69.2	192	G-05-CLC-12-025-6-4-B	6F258	6F252	6F254	6F255	6F2524
14	30	78.5	218	G-05-CLC-14-030-6-4-B	6F308	6F302	6F304	6F305	6F3024
17	40	92.3	257	G-05-CLC-17-040-6-4-B	N/A	N/A	6F404	6F405	N/A

**NOTES:**

1. Dimensions / Weights are not for construction purposes.
2. To use pre-configured model number, no changes are allowed with the exception of impeller trim.
3. Xylem pumps can be used with multiple motor brands. If no motor is listed, another manufacturer's is likely available, consult the submersible turbine pricebook (PTURBVS) for a complete list.

## Turbine

**IMPELLER MODEL:** 5CLC Trimmed

**BEP FLOW:** 112 GPM

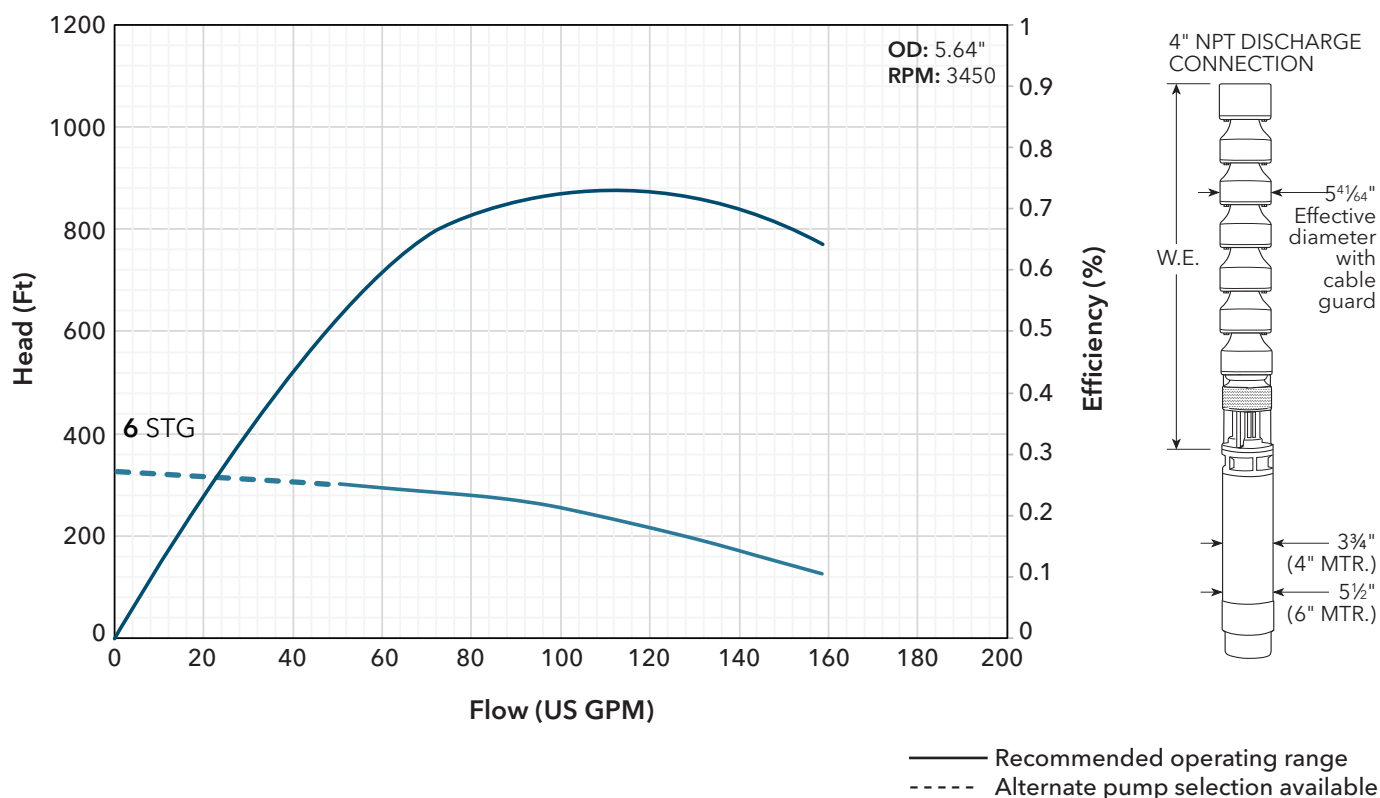

Stages	HP	W.E. Length (in)	W.E Wt. (lbs.)	W.E. Model Number	GWT Series Motor PN# (V)				
					200	230	460	575	230/460
6	10	41.4	114	G-05-CLC-06-010-6-4-B	6F108	6F102	6F104	6F105	6F1024

**NOTES:**

1. Dimensions / Weights are not for construction purposes.
2. To use pre-configured model number, no changes are allowed with the exception of impeller trim.
3. Xylem pumps can be used with multiple motor brands. If no motor is listed, another manufacturer's is likely available, consult the submersible turbine pricebook (PTURBVS) for a complete list
4. Configuration shown is equipped with trimmed impellers as standard to remain below NOL hp.

**IMPELLER MODEL: 5CHC**

**BEP FLOW: 155 GPM**

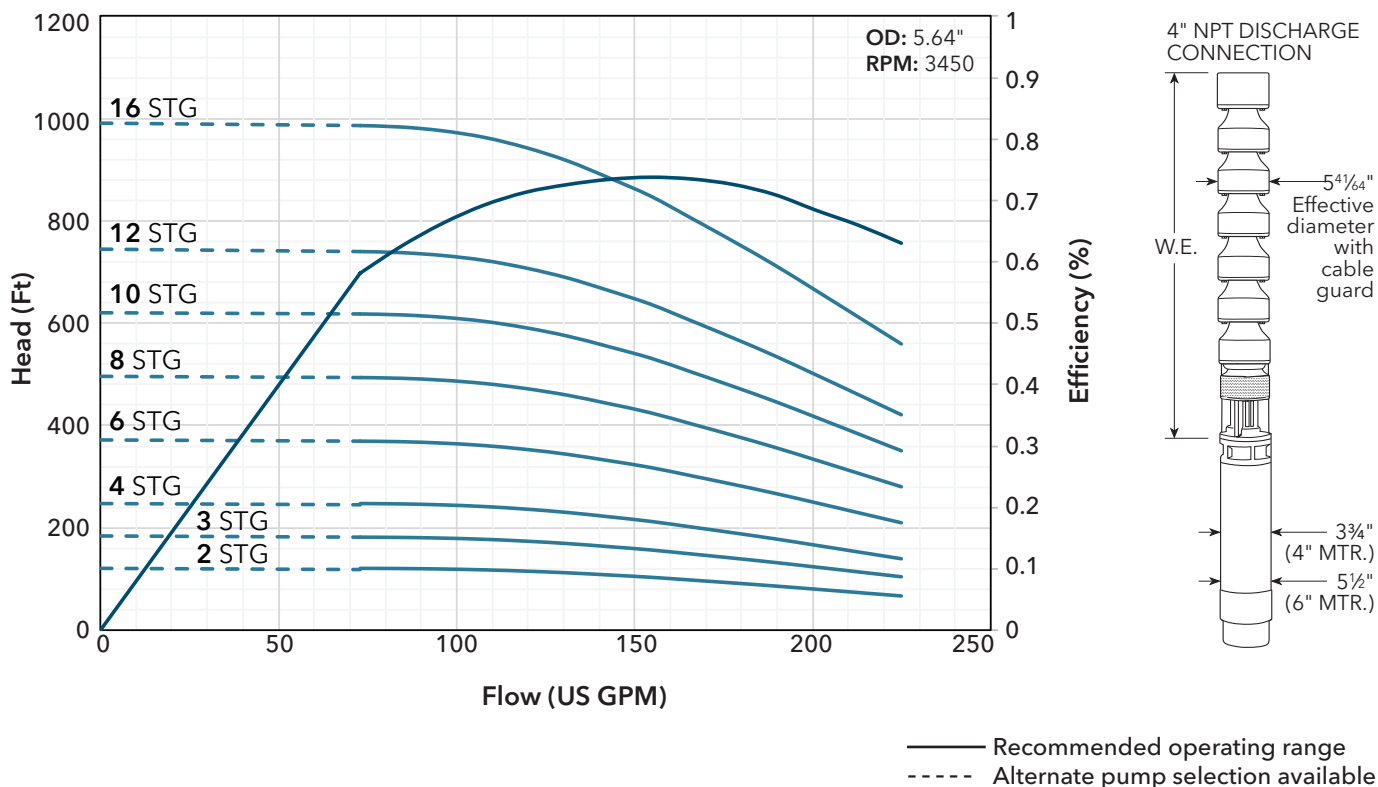

Stages	HP	W.E. Length (in)	W.E. Wt. (lbs.)	W.E. Model Number	GWT Series Motor PN# (V)				
					200	230	460	575	230/460
2	7.5	20.2	57	G-05-CHC-02-007-4-4-B	N/A	N/A	N/A	N/A	N/A
2	7.5	22.8	62	G-05-CHC-02-007-6-4-B	6F078	6F071	6F074	6F075	6F0724
3	10	25.2	70	G-05-CHC-03-010-4-4-B	N/A	N/A	N/A	N/A	N/A
3	10	27.5	75	G-05-CHC-03-010-6-4-B	6F108	6F101	6F104	6F105	6F1024
4	15	32.1	88	G-05-CHC-04-015-6-4-B	6F158	6F151	6F154	6F155	6F1524
6	20	41.4	114	G-05-CHC-06-020-6-4-B	6F208	6F202	6F204	6F205	6F2024
8	25	50.7	140	G-05-CHC-08-025-6-4-B	6F258	6F252	6F254	6F255	6F2524
10	30	59.9	166	G-05-CHC-10-030-6-4-B	6F308	6F302	6F304	6F305	6F3024
10	40	59.9	166	G-05-CHC-10-040-6-4-B	N/A	N/A	6F404	6F405	N/A
12	40	69.2	192	G-05-CHC-12-040-6-4-B	N/A	N/A	6F404	6F405	N/A
16	50	87.7	244	G-05-CHC-16-050-6-4-B	N/A	N/A	6F504	6F505	N/A

**NOTES:**

1. Dimensions / Weights are not for construction purposes.
2. Models are selected to be non-overloading across the duty curve, except for highlighted selections which are non-overloading at the best efficiency duty point but may overload recommended motor size towards runout. Highlighted models stay below 1.15 service factor.
3. To use pre-configured model number, no changes are allowed with the exception of impeller trim.
4. Xylem pumps can be used with multiple motor brands. If no motor is listed, another manufacturer's is likely available, consult the submersible turbine pricebook (PTURBVS) for a complete list.

**IMPELLER MODEL: 5TLC**

**BEP FLOW: 175 GPM**

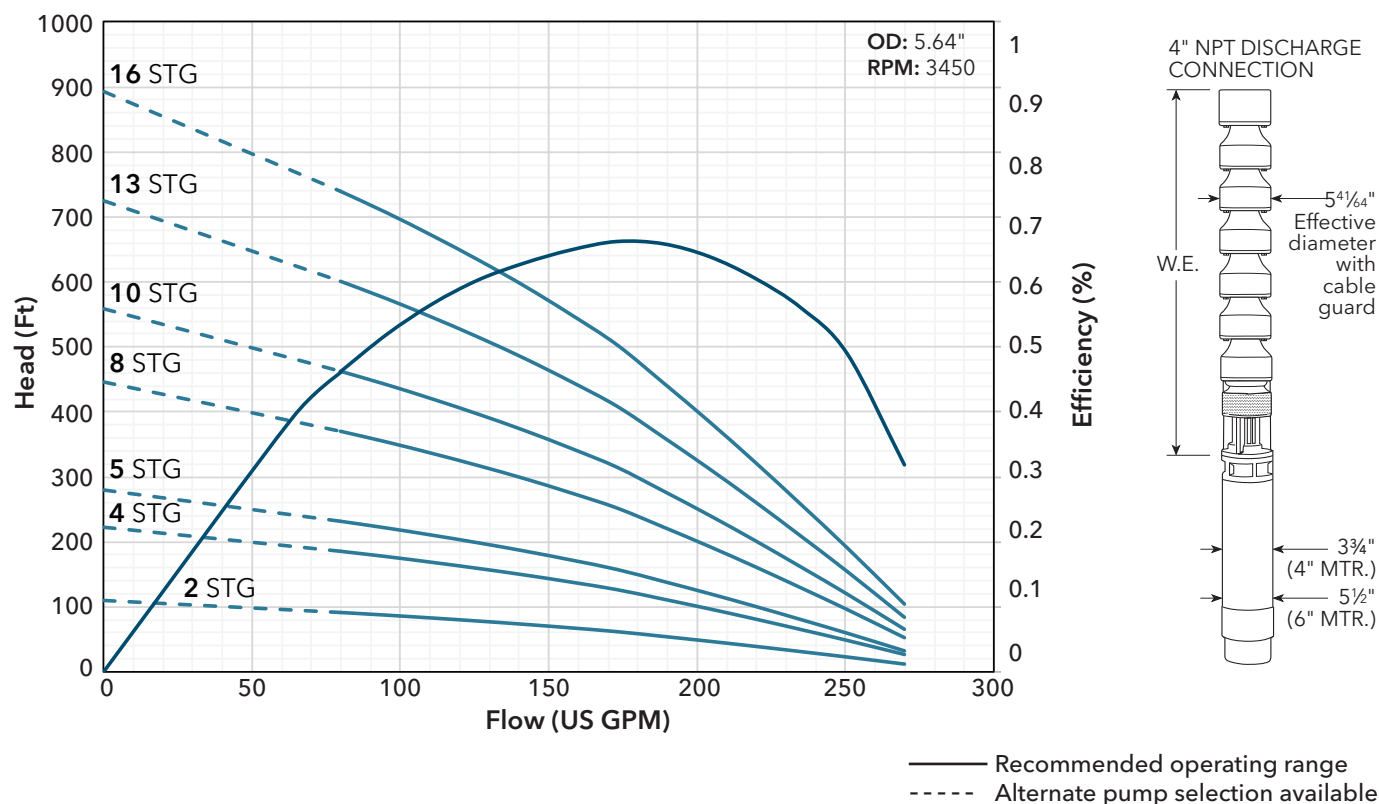

Stages	HP	W.E. Length (in)	W.E. Wt. (lbs.)	W.E. Model Number	GWT Series Motor PN# (V)				
					200	230	460	575	230/460
2	5	20.9	57	G-05-TLC-02-005-4-4-B	N/A	N/A	N/A	N/A	N/A
2	5	23.3	62	G-05-TLC-02-005-6-4-B	6F058	6F051	6F054	6F055	6F0524
4	10	30.4	82	G-05-TLC-04-010-4-4-B	N/A	N/A	N/A	N/A	N/A
4	10	32.8	87	G-05-TLC-04-010-6-4-B	6F108	6F101	6F104	6F105	6F1024
5	15	37.6	101	G-05-TLC-05-015-6-4-B	6F158	6F151	6F154	6F155	6F1524
8	20	52	140	G-05-TLC-08-020-6-4-B	6F208	6F202	6F204	6F205	6F2024
10	25	61.7	166	G-05-TLC-10-025-6-4-B	6F258	6F252	6F254	6F255	6F2524
13	30	76	205	G-05-TLC-13-030-6-4-B	6F308	6F302	6F304	6F305	6F3024
16	40	90.6	244	G-05-TLC-16-040-6-4-B	N/A	N/A	6F404	6F405	N/A

**NOTES:**

1. Dimensions / Weights are not for construction purposes.
2. To use pre-configured model number, no changes are allowed with the exception of impeller trim.
3. Xylem pumps can be used with multiple motor brands. If no motor is listed, another manufacturer's is likely available, consult the submersible turbine pricebook (PTURBVS) for a complete list.

**IMPELLER MODEL:** 5TLC Trimmed

**BEP FLOW:** 183 GPM

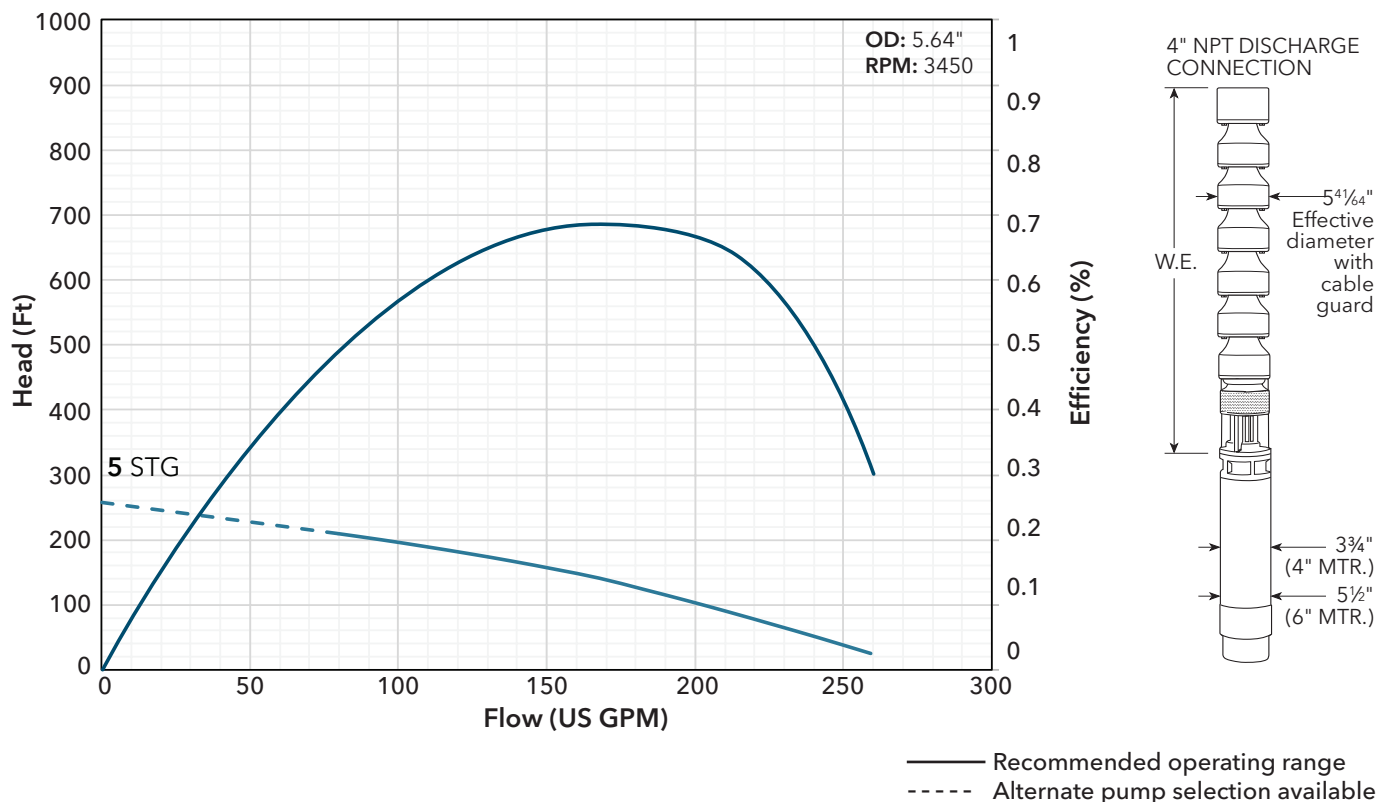

Stages	HP	W.E. Length (in)	W.E Wt. (lbs.)	W.E. Model Number	GWT Series Motor PN# (V)				
					200	230	460	575	230/460
5	10	37.6	101	G-05-TLC-05-010-6-4-B	6F108	6F102	6F104	6F105	6F1024

**NOTES:**

1. Dimensions / Weights are not for construction purposes.
2. To use pre-configured model number, no changes are allowed with the exception of impeller trim.
3. Xylem pumps can be used with multiple motor brands. If no motor is listed, another manufacturer's is likely available, consult the submersible turbine pricebook (PTURBVS) for a complete list
4. Configuration shown is equipped with trimmed impellers as standard to remain below NOL hp.

**IMPELLER MODEL: 5THC**

**BEP FLOW: 243 GPM**

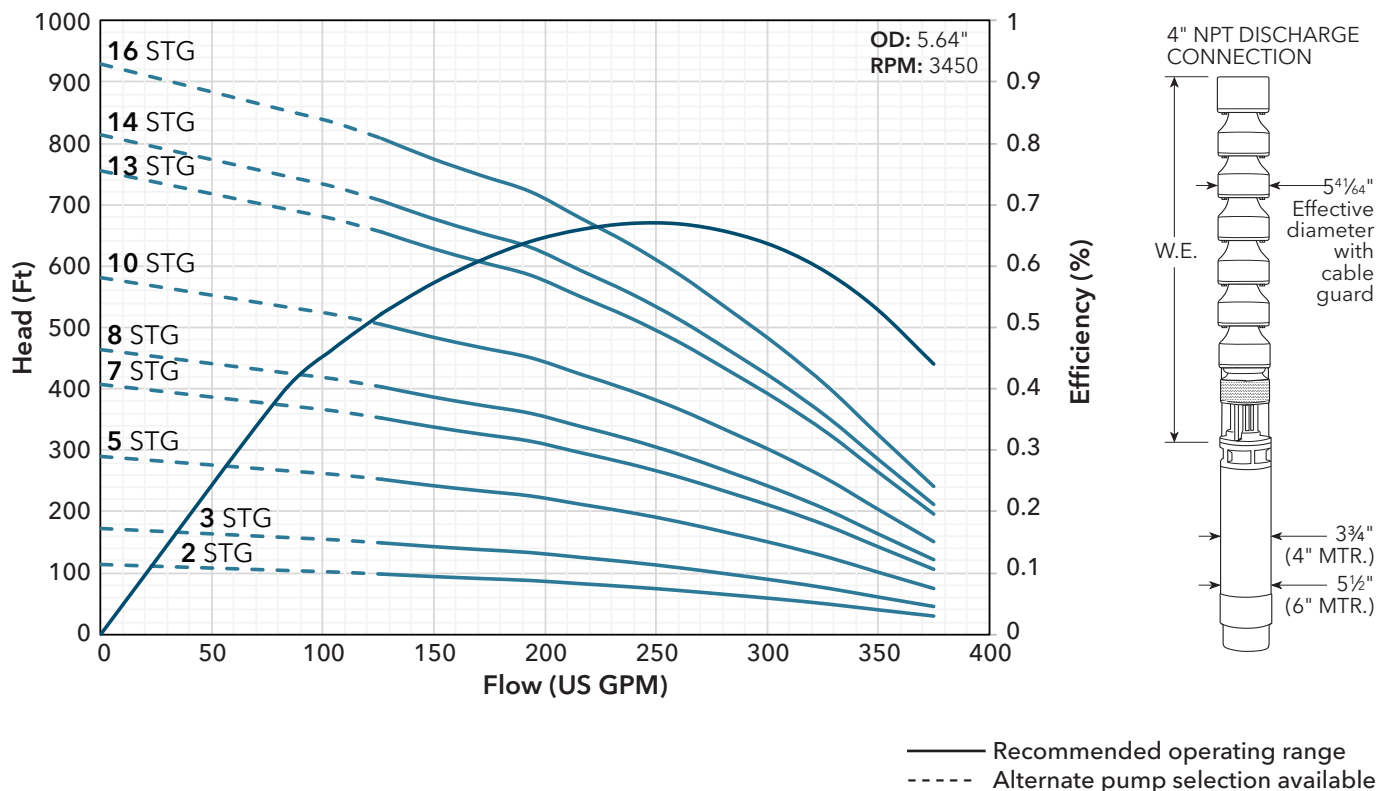

Stages	HP	W.E. Length (in)	W.E. Wt. (lbs.)	W.E. Model Number	GWT Series Motor PN# (V)				
					200	230	460	575	230/460
2	7.5	20.9	57	G-05-THC-02-007-4-4-B	N/A	N/A	N/A	N/A	N/A
2	7.5	23.3	62	G-05-THC-02-007-6-4-B	6F078	6F071	6F074	6F075	6F0724
3	15	28	75	G-05-THC-03-015-6-4-B	6F158	6F151	6F154	6F155	6F1524
5	20	37.6	101	G-05-THC-05-020-6-4-B	6F208	6F202	6F204	6F205	6F2024
7	25	47.3	127	G-05-THC-07-025-6-4-B	6F258	6F252	6F254	6F255	6F2524
8	30	52	153	G-05-THC-08-030-6-4-B	6F308	6F302	6F304	6F305	6F3024
10	40	61.7	166	G-05-THC-10-040-6-4-B	N/A	N/A	6F404	6F405	N/A
13	50	76	218	G-05-THC-13-050-6-4-B	N/A	N/A	6F504	6F505	N/A
14	50	80.7	221	G-05-THC-14-050-6-4-B	N/A	N/A	6F504	6F505	N/A
16	60	90.6	257	G-05-THC-16-060-6-4-B	N/A	N/A	86F604	86F605	N/A

**NOTES:**

1. Dimensions / Weights are not for construction purposes.
2. To use pre-configured model number, no changes are allowed with the exception of impeller trim.
3. Xylem pumps can be used with multiple motor brands. If no motor is listed, another manufacturer's is likely available, consult the submersible turbine pricebook (PTURBVS) for a complete list.

**IMPELLER MODEL:** 5THC Trimmed

**BEP FLOW:** 260 GPM

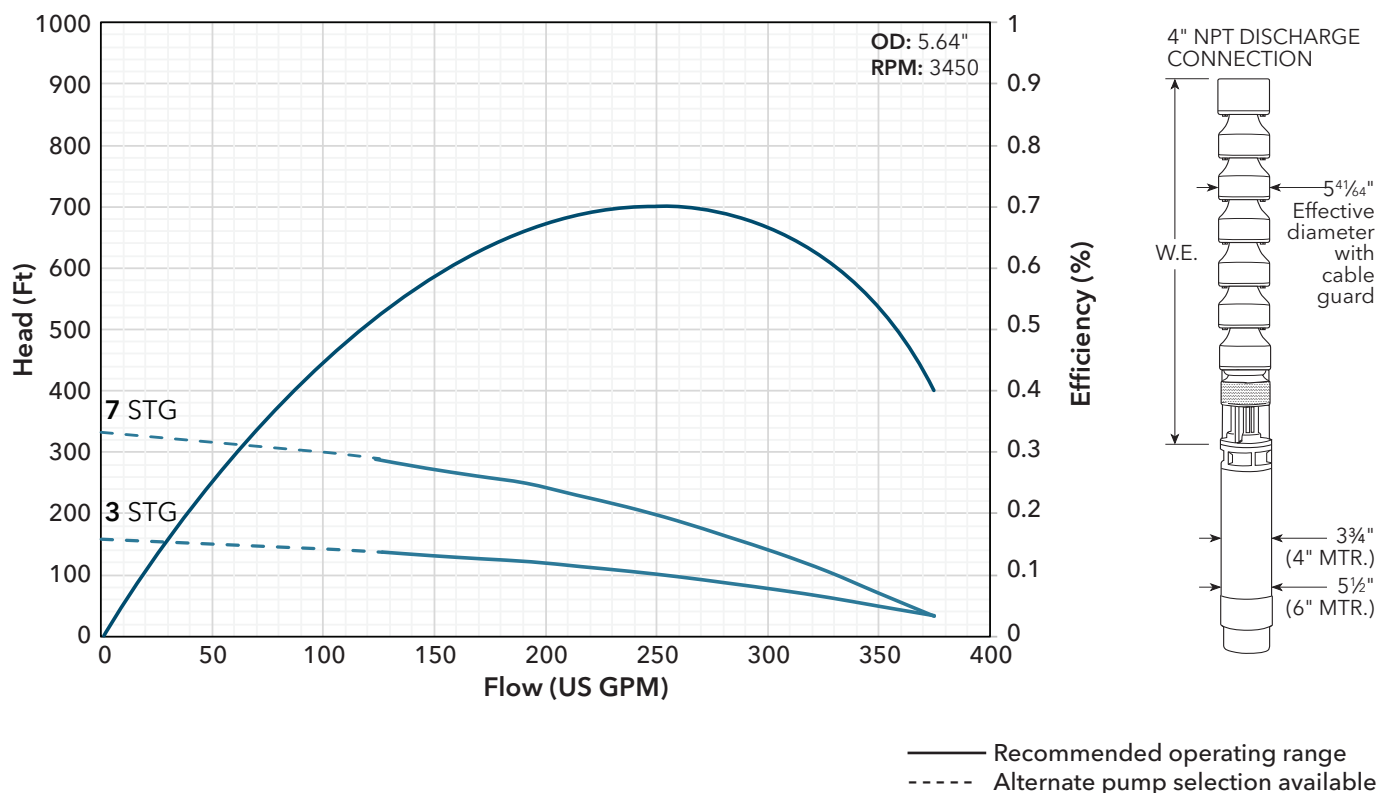

Stages	HP	W.E. Length (in)	W.E. Wt. (lbs.)	W.E. Model Number	GWT Series Motor PN# (V)				
					200	230	460	575	230/460
3	10	28	75	G-05-THC-03-010-6-4-B	6F108	6F102	6F104	6F105	6F1024
7	20	47.3	127	G-05-THC-07-020-6-4-B	6F208	6F202	6F204	6F205	6F2024

**NOTES:**

1. Dimensions / Weights are not for construction purposes.
2. To use pre-configured model number, no changes are allowed with the exception of impeller trim.
3. Xylem pumps can be used with multiple motor brands. If no motor is listed, another manufacturer's is likely available, consult the submersible turbine pricebook (PTURBVS) for a complete list
4. Configuration shown is equipped with trimmed impellers as standard to remain below NOL hp.

## Turbine

**IMPELLER MODEL: 6CLC**

**BEP FLOW: 190 GPM**

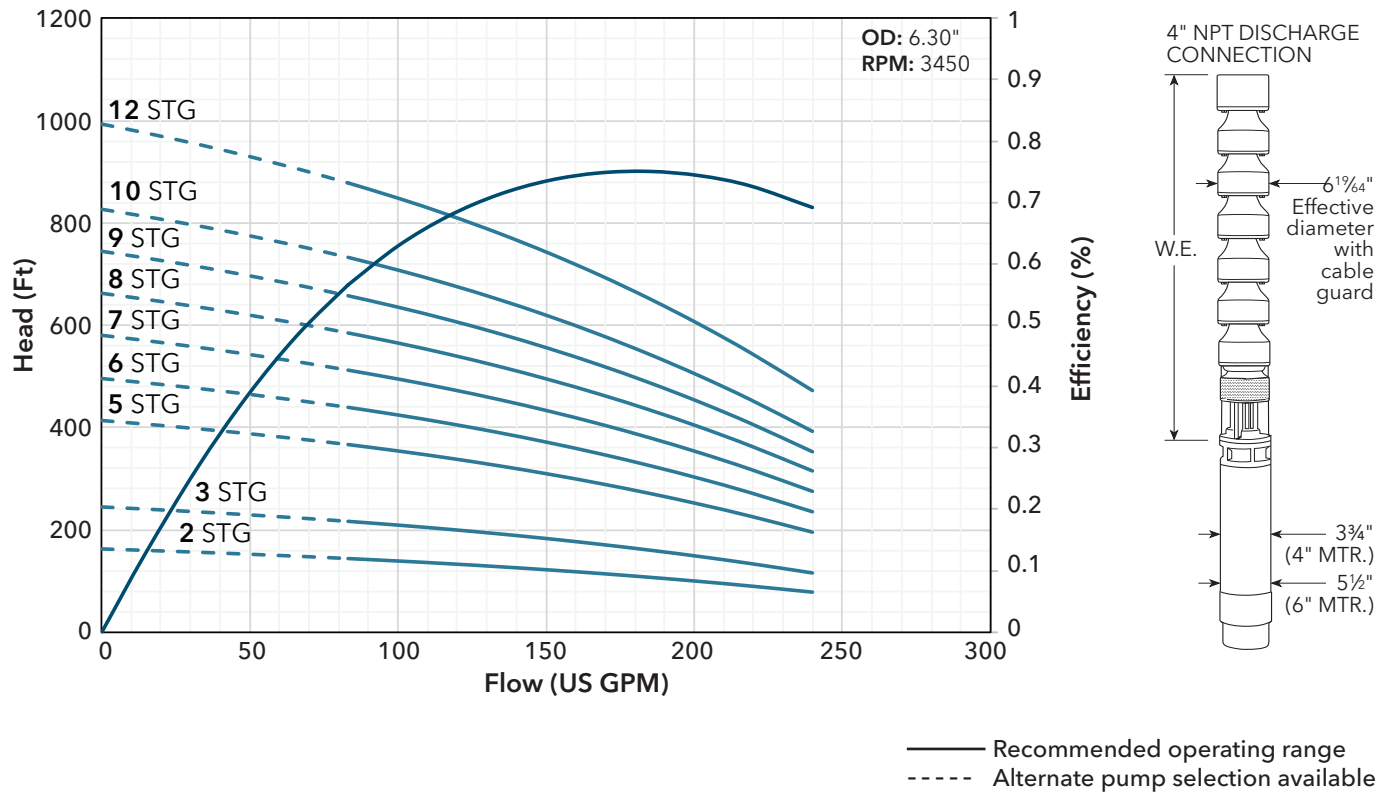

Stages	HP	W.E. Length (in)	W.E. Wt. (lbs.)	W.E. Model Number	GWT Series Motor PN# (V)				
					200	230	460	575	230/460
2	7.5	22.4	67	G-06-CLC-02-007-4-4-B	N/A	N/A	N/A	N/A	N/A
2	7.5	24.6	72	G-06-CLC-02-007-6-4-B	6F078	6F071	6F074	6F075	6F0724
3	10	34.8	89	G-06-CLC-03-010-6-4-B	6F108	6F101	6F104	6F105	6F1024
3	15	34.8	89	G-06-CLC-03-015-6-4-B	6F158	6F151	6F154	6F155	6F1524
5	20	40	123	G-06-CLC-05-020-6-4-B	6F208	6F202	6F204	6F205	6F2024
6	20	45.2	140	G-06-CLC-06-020-6-4-B	6F208	6F202	6F204	6F205	6F2024
6	25	45.2	140	G-06-CLC-06-025-6-4-B	6F258	6F252	6F254	6F255	6F2524
7	25	50.3	157	G-06-CLC-07-025-6-4-B	6F258	6F252	6F254	6F255	6F2524
8	25	55.4	174	G-06-CLC-08-025-6-4-B	6F258	6F252	6F254	6F255	6F2524
8	30	55.4	174	G-06-CLC-08-030-6-4-B	6F308	6F302	6F304	6F305	6F3024
9	30	60.5	191	G-06-CLC-09-030-6-4-B	6F308	6F302	6F304	6F305	6F3024
9	40	60.5	191	G-06-CLC-09-040-6-4-B	N/A	N/A	6F404	6F405	N/A
10	30	65.6	208	G-06-CLC-10-030-6-4-B	6F308	6F302	6F304	6F305	6F3024
10	40	65.6	208	G-06-CLC-10-040-6-4-B	N/A	N/A	6F404	6F405	N/A
12	40	75.8	242	G-06-CLC-12-040-6-4-B	N/A	N/A	6F404	6F405	N/A
12	50	75.8	242	G-06-CLC-12-050-6-4-B	N/A	N/A	6F504	6F505	N/A

**NOTES:**

1. Dimensions / Weights are not for construction purposes.
2. Models are selected to be non-overloading across the duty curve, except for highlighted selections which are non-overloading at the best efficiency duty point but may overload recommended motor size towards runout. Highlighted models stay below 1.15 service factor.
3. To use pre-configured model number, no changes are allowed with the exception of impeller trim.
4. Xylem pumps can be used with multiple motor brands. If no motor is listed, another manufacturer's is likely available, consult the submersible turbine pricebook (PTURBVS) for a complete list.



**IMPELLER MODEL:** 6CHC

**BEP FLOW:** 230 GPM

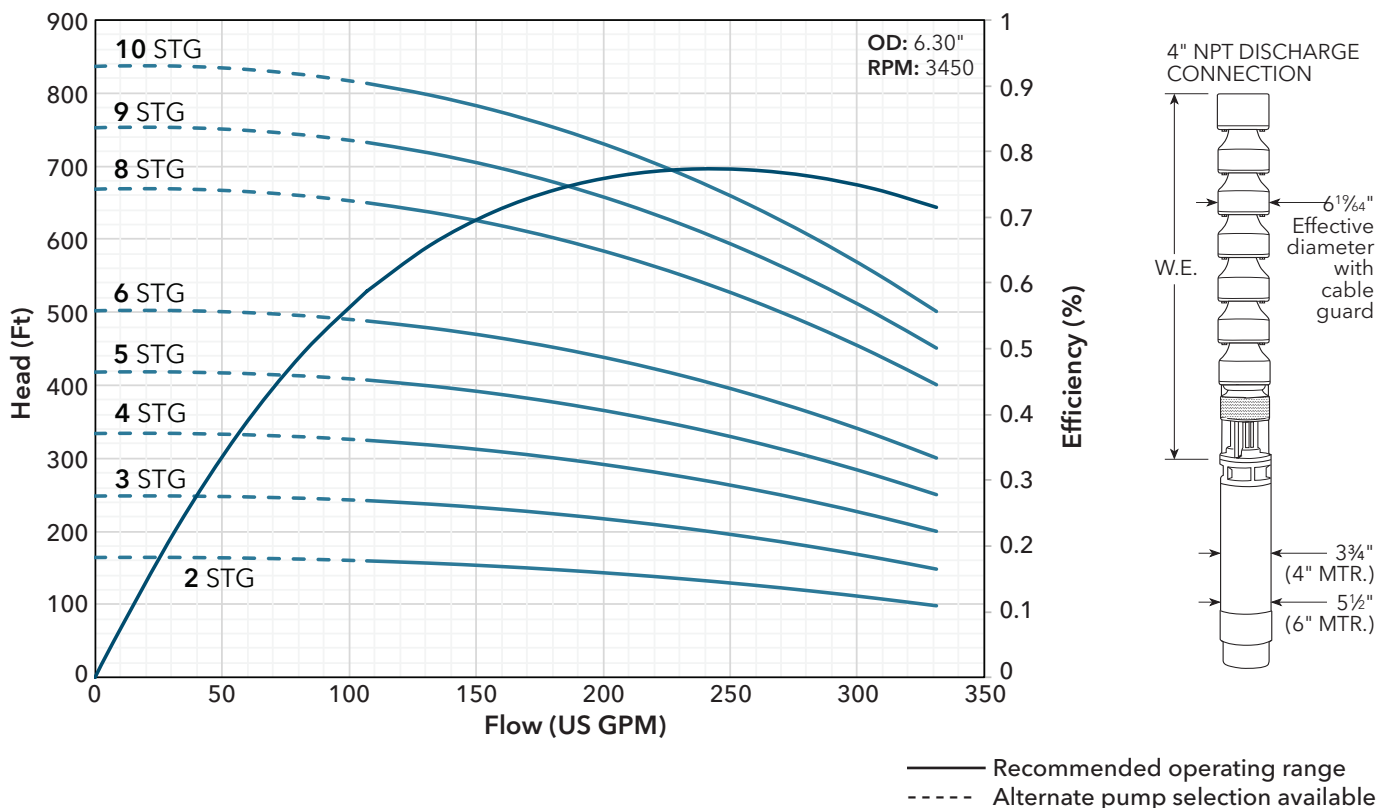

Stages	HP	W.E. Length (in)	W.E. Wt. (lbs.)	W.E. Model Number	GWT Series Motor PN# (V)				
					200	230	460	575	230/460
2	15	24.6	72	G-06-CHC-02-015-6-4-B	6F158	6F151	6F154	6F155	6F1524
3	20	29.7	89	G-06-CHC-03-020-6-4-B	6F208	6F202	6F204	6F205	6F2024
4	25	34.8	106	G-06-CHC-04-025-6-4-B	6F258	6F252	6F254	6F255	6F2524
5	30	40	123	G-06-CHC-05-030-6-4-B	6F308	6F302	6F304	6F305	6F3024
6	40	40.3	157	G-06-CHC-06-040-6-4-B	N/A	N/A	6F404	6F405	N/A
8	50	55.4	174	G-06-CHC-08-050-6-4-B	N/A	N/A	6F504	6F505	N/A
9	60	60.5	191	G-06-CHC-09-050-6-4-B	N/A	N/A	86F604	86F605	N/A
9	60	60.5	191	G-06-CHC-09-060-6-4-B	N/A	N/A	86F604	86F605	N/A
10	60	65.6	208	G-06-CHC-10-060-6-4-B	N/A	N/A	86F604	86F605	N/A

**NOTES:**

1. Dimensions / Weights are not for construction purposes.
2. Models are selected to be non-overloading across the duty curve, except for highlighted selections which are non-overloading at the best efficiency duty point but may overload recommended motor size towards runout. Highlighted models stay below 1.15 service factor.
3. To use pre-configured model number, no changes are allowed with the exception of impeller trim
4. Xylem pumps can be used with multiple motor brands. If no motor is listed, another manufacturer's is likely available, consult the submersible turbine pricebook (PTURBVS) for a complete list.

**IMPELLER MODEL:** 7WALC

**BEP FLOW:** 224 GPM

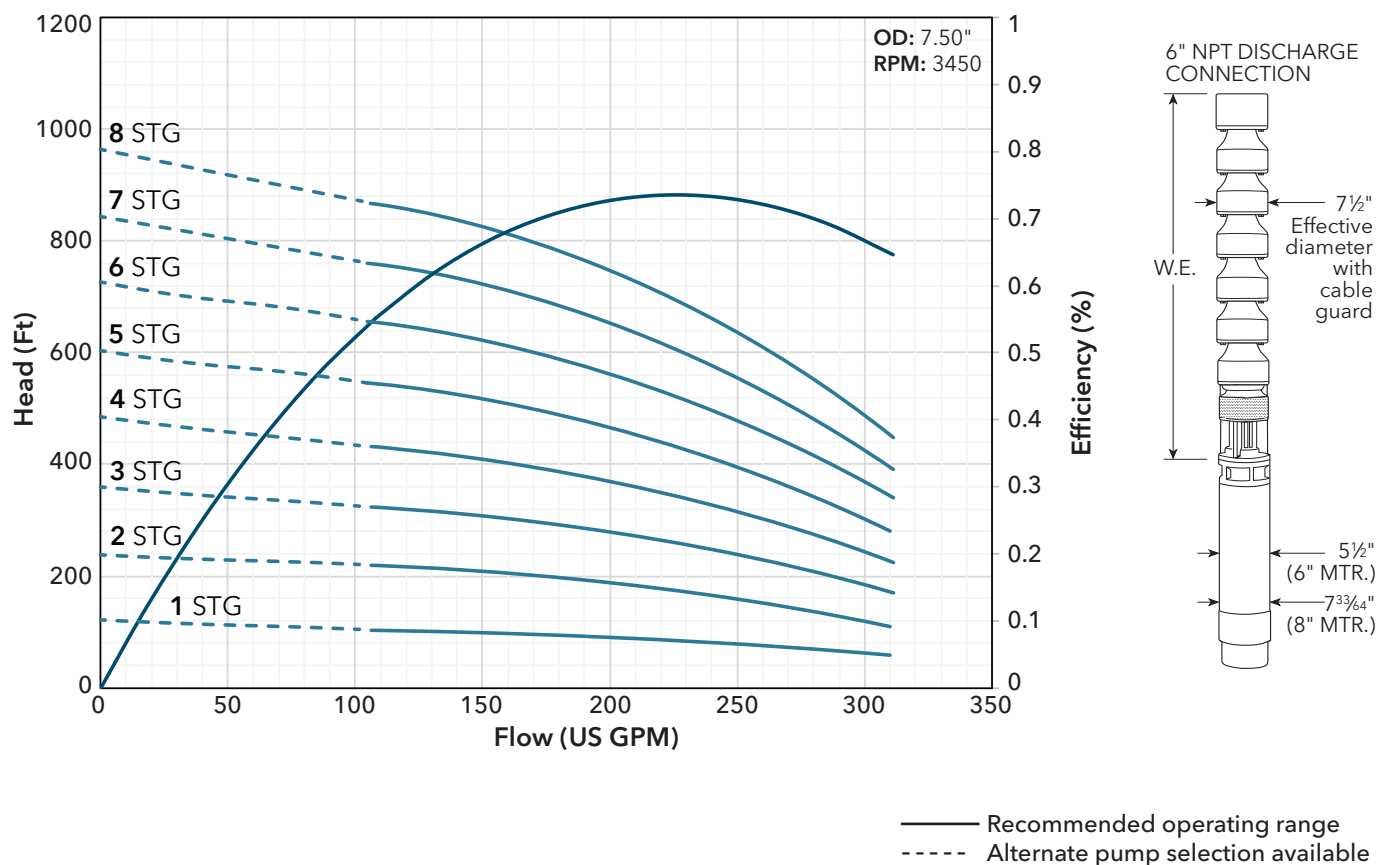

Stages	HP	W.E. Length (in)	W.E. Wt. (lbs.)	W.E. Model Number	GWT Series Motor PN# (V)				
					200	230	460	575	230/460
1	7.5	22	68	G-07-WAL-01-007-6-6-B	6F078	6F071	6F074	6F075	6F0724
2	15	27.5	98	G-07-WAL-02-015-6-6-B	6F158	6F151	6F154	6F155	6F1524
3	20	33	128	G-07-WAL-03-020-6-6-B	6F208	6F202	6F204	6F205	6F2024
3	25	33	128	G-07-WAL-03-025-6-6-B	6F258	6F252	6F254	6F255	6F2524
4	30	38.5	158	G-07-WAL-04-030-6-6-B	6F308	6F302	6F304	6F305	6F3024
5	40	44	188	G-07-WAL-05-040-6-6-B	N/A	N/A	6F404	6F405	N/A
6	40	49.5	218	G-07-WAL-06-040-6-6-B	N/A	N/A	6F404	6F405	N/A
6	50	49.5	218	G-07-WAL-06-050-6-6-B	N/A	N/A	6F504	6F505	N/A

**NOTES:**

1. Dimensions / Weights are not for construction purposes.
2. Models are selected to be non-overloading across the duty curve, except for highlighted selections which are non-overloading at the best efficiency duty point but may overload recommended motor size towards runout. Highlighted models stay below 1.15 service factor.
3. To use pre-configured model number, no changes are allowed with the exception of impeller trim.
4. Xylem pumps can be used with multiple motor brands. If no motor is listed, another manufacturer's is likely available, consult the submersible turbine pricebook (PTURBVS) for a complete list.

**IMPELLER MODEL:** 7WALC Trimmed

**BEP FLOW:** 220 GPM

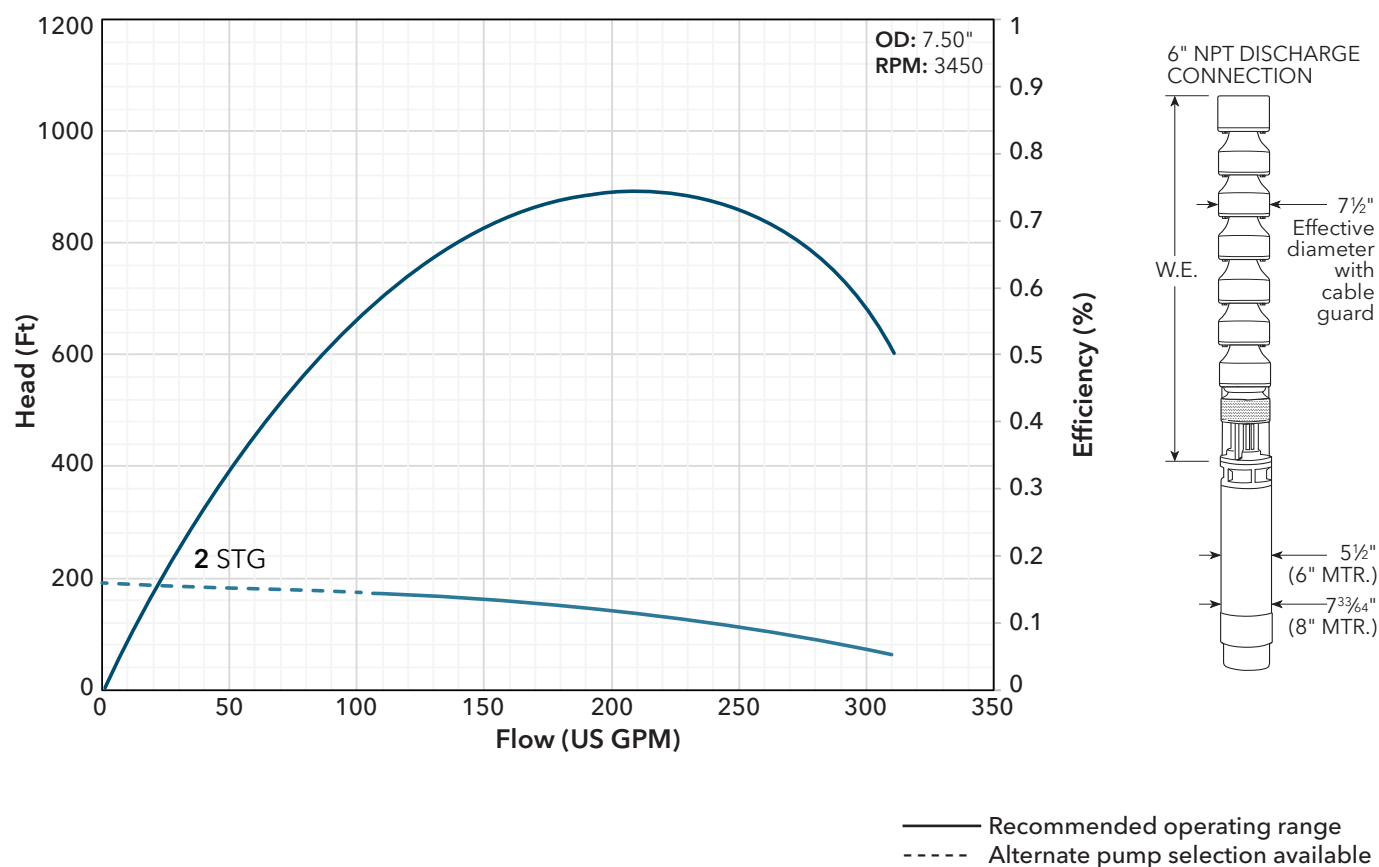

Stages	HP	W.E. Length (in)	W.E Wt. (lbs.)	W.E. Model Number	GWT Series Motor PN# (V)				
					200	230	460	575	230/460
2	10	27.5	98	G-07-WAL-02-010-6-6-B	6F108	6F102	6F104	6F105	6F1024

**NOTES:**

1. Dimensions / Weights are not for construction purposes.
2. To use pre-configured model number, no changes are allowed with the exception of impeller trim.
3. Xylem pumps can be used with multiple motor brands. If no motor is listed, another manufacturer's is likely available, consult the submersible turbine pricebook (PTURBVS) for a complete list
4. Configuration shown is equipped with trimmed impellers as standard to remain below NOL hp.

**IMPELLER MODEL:** 7WAHC

**BEP FLOW:** 270 GPM

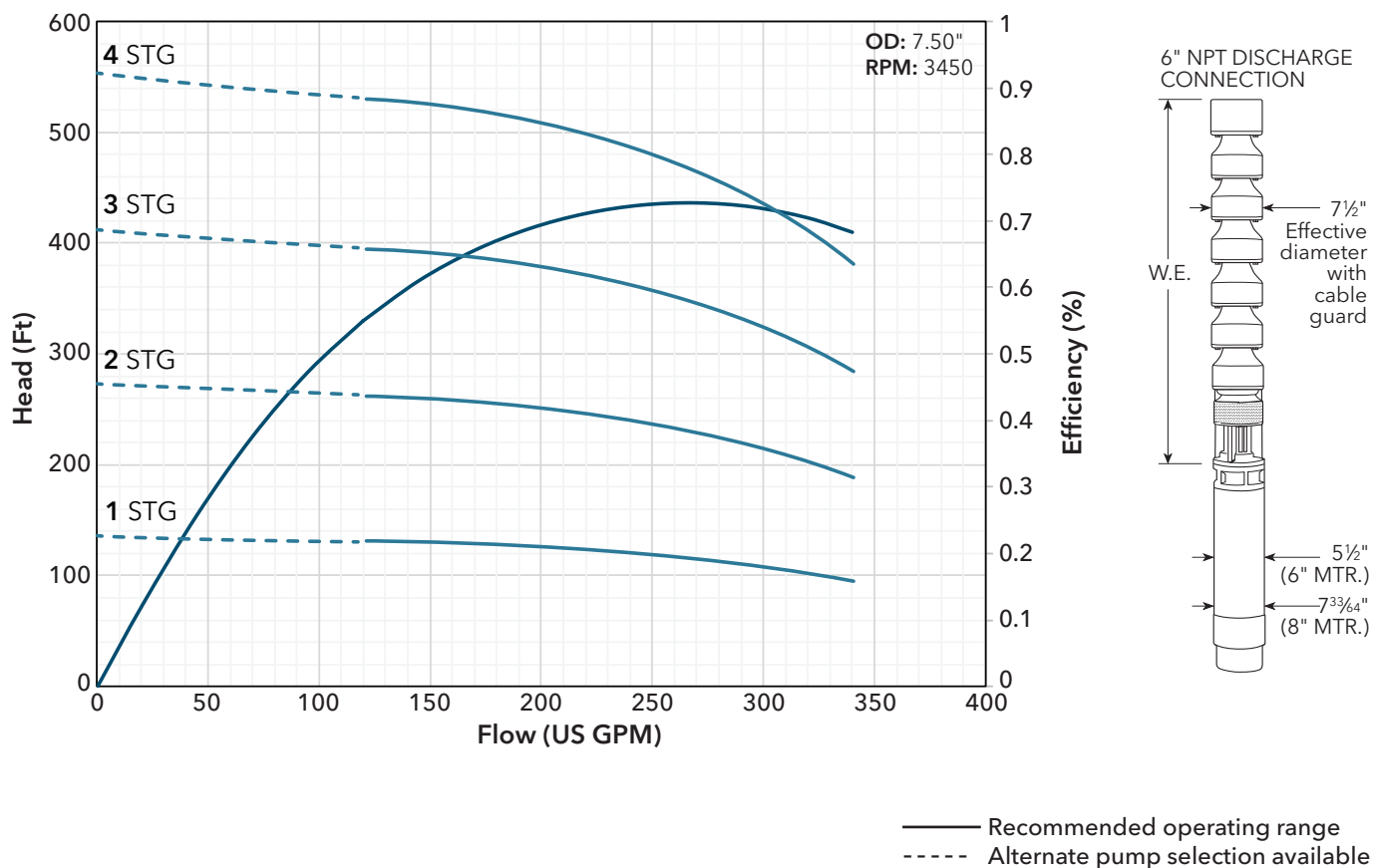

Stages	HP	W.E. Length (in)	W.E. Wt. (lbs.)	W.E. Model Number	GWT Series Motor PN# (V)				
					200	230	460	575	230/460
1	15	22	68	G-07-WAH-01-015-6-6-B	6F158	6F151	6F154	6F155	6F1524
2	25	27.5	98	G-07-WAH-02-025-6-6-B	6F258	6F252	6F254	6F255	6F2524
3	40	33	128	G-07-WAH-03-040-6-6-B	N/A	N/A	6F404	6F405	N/A
4	50	38.5	158	G-07-WAH-04-050-8-6-B	N/A	N/A	6F504	6F505	N/A

**NOTES:**

1. Dimensions / Weights are not for construction purposes.
2. To use pre-configured model number, no changes are allowed with the exception of impeller trim.
3. Xylem pumps can be used with multiple motor brands. If no motor is listed, another manufacturer's is likely available, consult the submersible turbine pricebook (PTURBVS) for a complete list.

**IMPELLER MODEL:** 7WAHC Trimmed

**BEP FLOW:** 261 GPM

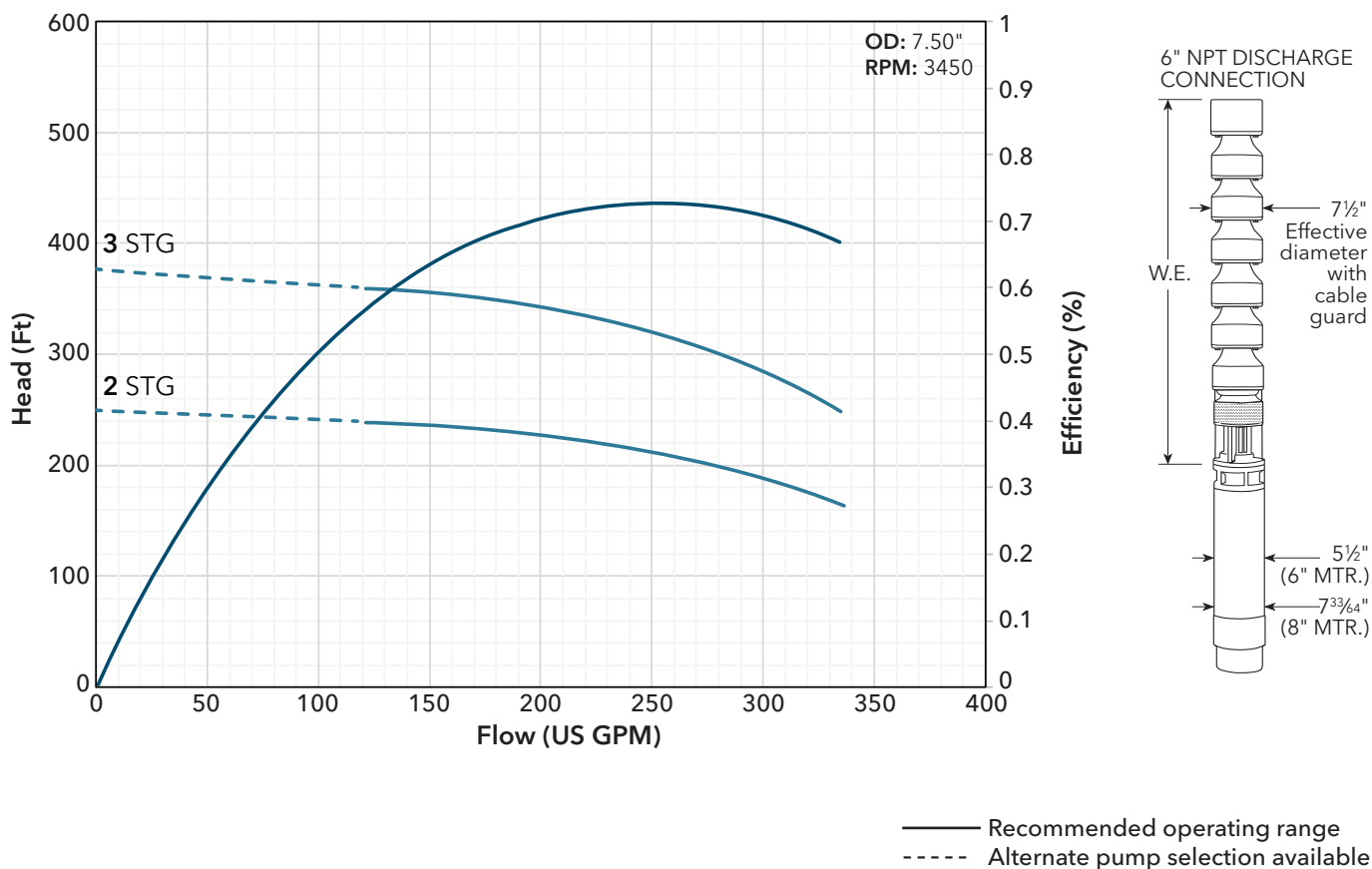

Stages	HP	W.E. Length (in)	W.E. Wt. (lbs.)	W.E. Model Number	GWT Series Motor PN# (V)				
					200	230	460	575	230/460
2	20	27.5	98	G-07-WAH-02-020-6-6-B	6F208	6F202	6F204	6F205	6F2024
3	30	33	128	G-07-WAH-03-030-6-6-B	N/A	N/A	6F304	6F305	N/A

**NOTES:**

1. Dimensions / Weights are not for construction purposes.
2. To use pre-configured model number, no changes are allowed with the exception of impeller trim.
3. Xylem pumps can be used with multiple motor brands. If no motor is listed, another manufacturer's is likely available, consult the submersible turbine pricebook (PTURBVS) for a complete list
4. Configuration shown is equipped with trimmed impellers as standard to remain below NOL hp.

**IMPELLER MODEL: 7CLC**

**BEP FLOW: 375 GPM**

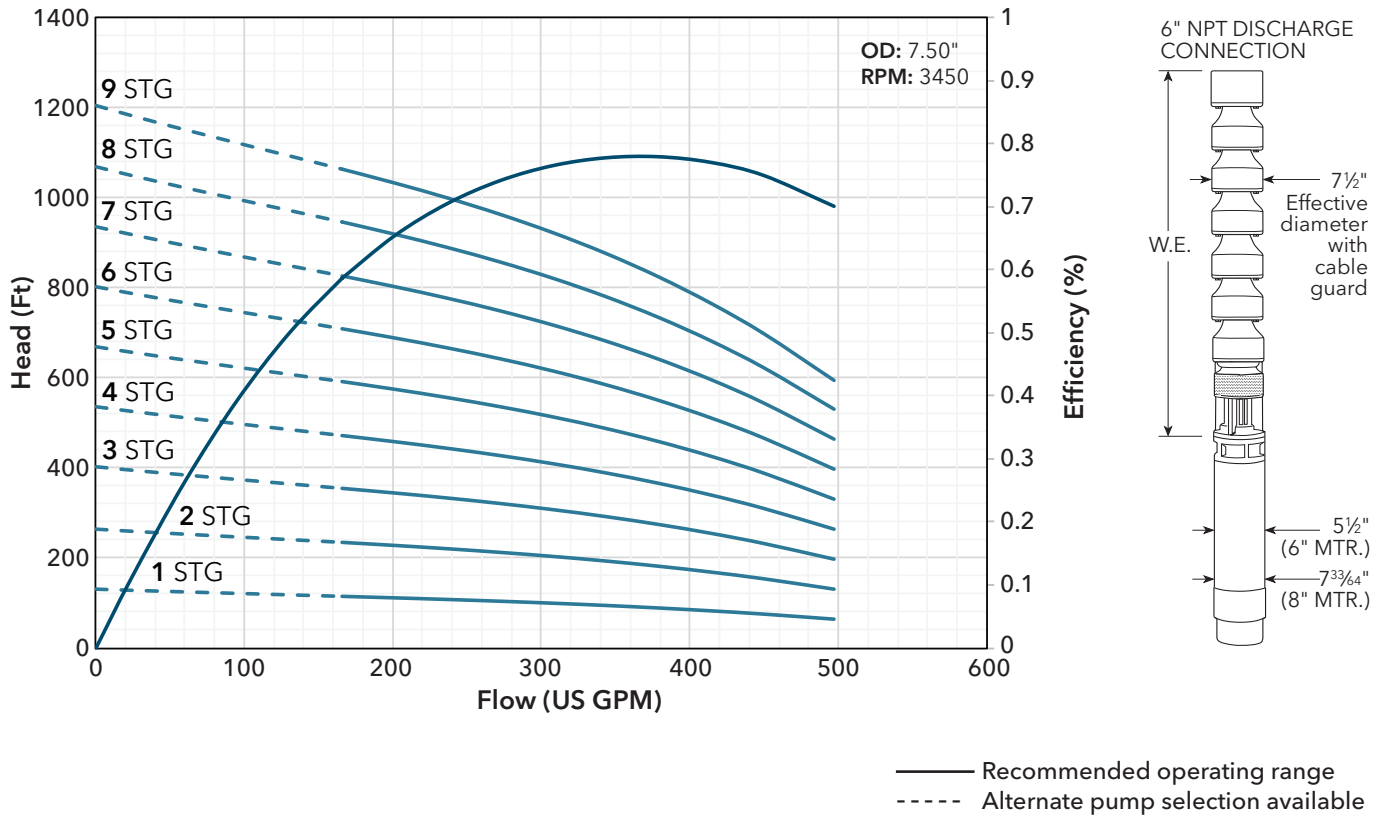

Stages	HP	W.E. Length (in)	W.E Wt. (lbs.)	W.E. Model Number	GWT Series Motor PN# (V)				
					200	230	460	575	230/460
1	15	22.9	75	G-07-CLC-01-015-6-6-B	6F158	6F151	6F154	6F155	6F1524
2	25	29.3	103	G-07-CLC-02-025-6-6-B	6F258	6F252	6F254	6F255	6F2524
3	40	35.6	131	G-07-CLC-03-040-6-6-B	N/A	N/A	6F404	6F405	N/A
4	50	42	159	G-07-CLC-04-050-8-6-B	N/A	N/A	6F504	6F505	N/A
5	60	48.4	187	G-07-CLC-05-060-8-6-B	N/A	N/A	86F604	86F605	N/A
6	75	54.8	215	G-07-CLC-06-075-8-6-B	N/A	N/A	8F754	8F755	N/A
7	100	62.8	255	G-07-CLC-07-100-8-6-B	N/A	N/A	8F1004	8F1005	N/A
8	100	70.8	283	G-07-CLC-08-100-8-6-B	N/A	N/A	8F1004	8F1005	N/A
9	100	75.8	311	G-07-CLC-09-100-8-6-B	N/A	N/A	8F1004	8F1005	N/A
9	125	75.8	311	G-07-CLC-09-125-8-6-B	N/A	N/A	8F1254	8F1255	N/A

**NOTES:**

- Dimensions / Weights are not for construction purposes.
- Models are selected to be non-overloading across the duty curve, except for highlighted selections which are non-overloading at the best efficiency duty point but may overload recommended motor size towards runout. Highlighted models stay below 1.15 service factor.
- To use pre-configured model number, no changes are allowed with the exception of impeller trim.

## Turbine

**IMPELLER MODEL:** 7CLC Trimmed

**BEP FLOW:** 308 GPM

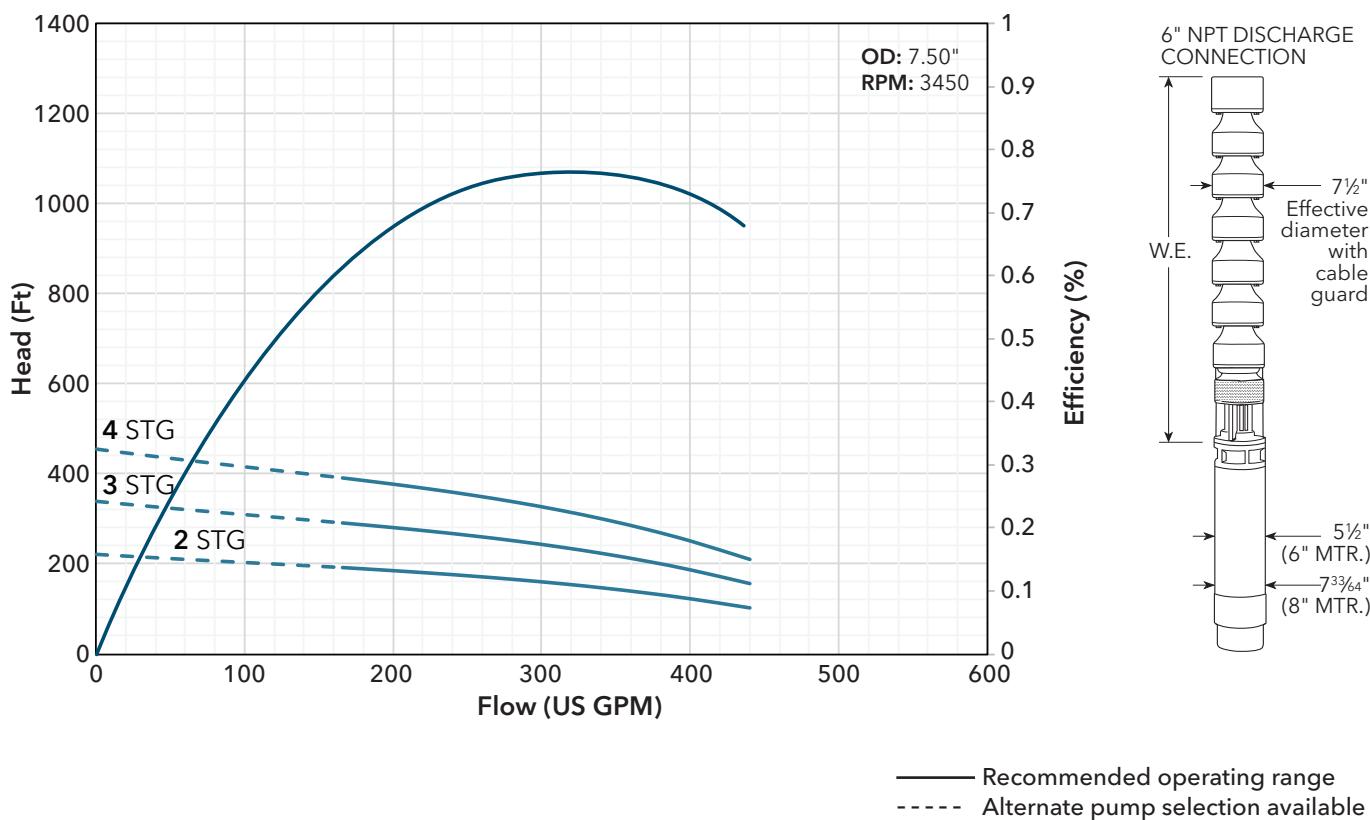

Stages	HP	W.E. Length (in)	W.E. Wt. (lbs.)	W.E. Model Number	GWT Series Motor PN# (V)				
					200	230	460	575	230/460
2	20	29.3	103	G-07-CLC-02-020-6-6-B	6F208	6F202	6F204	6F205	6F2024
3	30	35.6	131	G-07-CLC-03-030-6-6-B	N/A	N/A	6F304	6F305	N/A
4	40	42	159	G-07-CLC-04-040-8-6-B	N/A	N/A	6F404	6F405	N/A

**NOTES:**

1. Dimensions / Weights are not for construction purposes.
2. To use pre-configured model number, no changes are allowed with the exception of impeller trim.
3. Xylem pumps can be used with multiple motor brands. If no motor is listed, another manufacturer's is likely available, consult the submersible turbine pricebook (PTURBVS) for a complete list
4. Configuration shown is equipped with trimmed impellers as standard to remain below NOL hp.

## Turbine

**IMPELLER MODEL:** 7CHC

**BEP FLOW:** 448 GPM

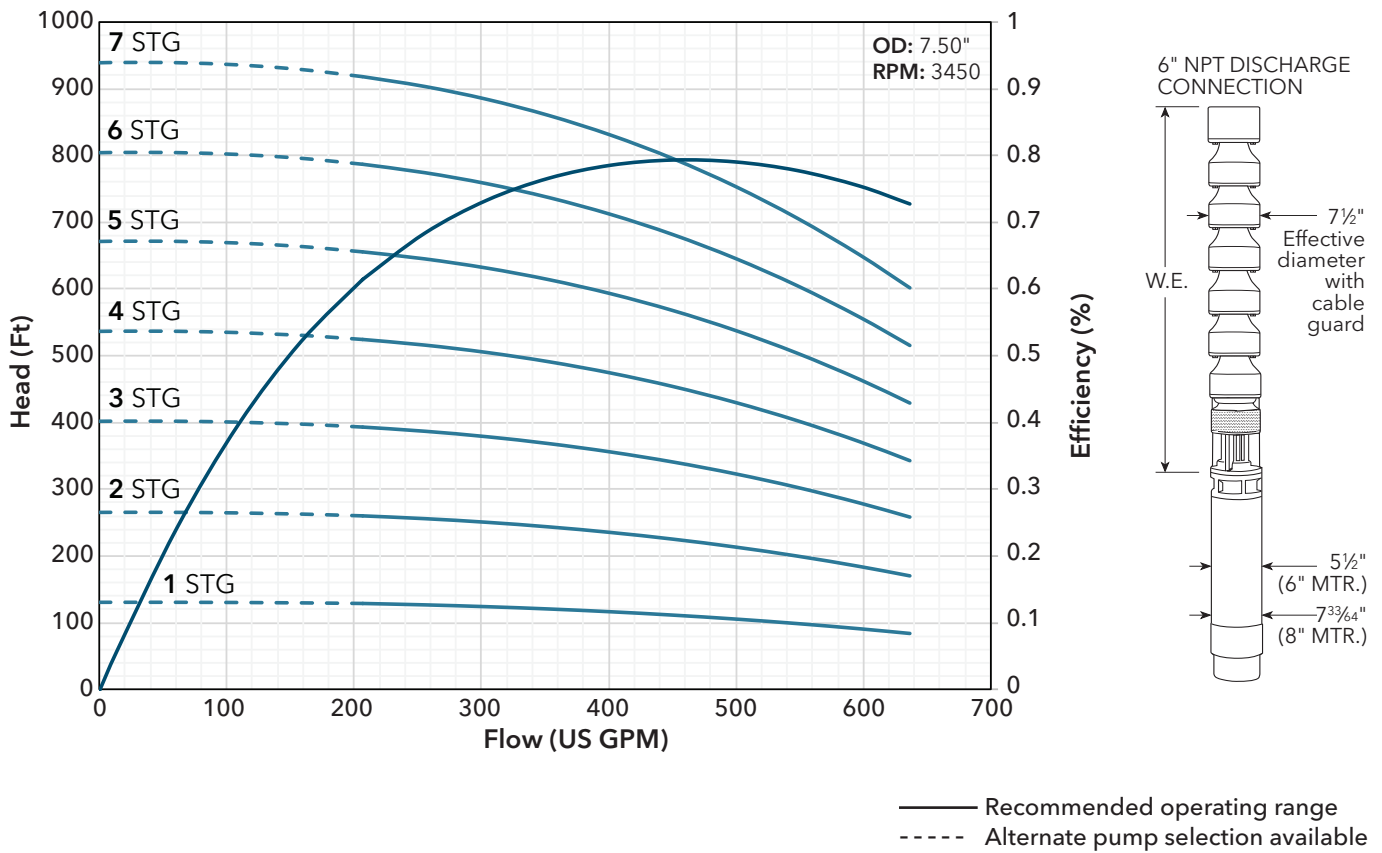

Stages	HP	W.E. Length (in)	W.E. Wt. (lbs.)	W.E. Model Number	GWT Series Motor PN# (V)				
					200	230	460	575	230/460
1	20	22.9	75	G-07-CHC-01-020-6-6-B	6F208	6F202	6F204	6F205	6F2024
2	40	29.3	103	G-07-CHC-02-040-6-6-B	N/A	N/A	6F404	6F405	N/A
3	50	35.6	131	G-07-CHC-03-050-8-6-B	N/A	N/A	8F504	8F505	N/A
3	60	35.6	131	G-07-CHC-03-060-8-6-B	N/A	N/A	86F604	86F605	N/A
4	75	43.6	171	G-07-CHC-04-075-8-6-B	N/A	N/A	8F754	8F755	N/A
5	100	50	199	G-07-CHC-05-100-8-6-B	N/A	N/A	8F1004	8F1005	N/A
6	100	56.5	227	G-07-CHC-06-100-8-6-B	N/A	N/A	8F1004	8F1005	N/A
6	125	56.5	227	G-07-CHC-06-125-8-6-B	N/A	N/A	8F1254	8F1255	N/A
7	125	63	255	G-07-CHC-07-125-8-6-B	N/A	N/A	8F1254	8F1255	N/A
7	150	63	255	G-07-CHC-07-150-8-6-B	N/A	N/A	8F1504	8F1505	N/A

**NOTES:**

1. Dimensions / Weights are not for construction purposes.
2. Models are selected to be non-overloading across the duty curve, except for highlighted selections which are non-overloading at the best efficiency duty point but may overload recommended motor size towards runout. Highlighted models stay below 1.15 service factor.
3. To use pre-configured model number, no changes are allowed with the exception of impeller trim.
4. Xylem pumps can be used with multiple motor brands. If no motor is listed, another manufacturer's is likely available, consult the submersible turbine pricebook (PTURBVS) for a complete list.



**IMPELLER MODEL:** 7CHC Trimmed

**BEP FLOW:** 422 GPM

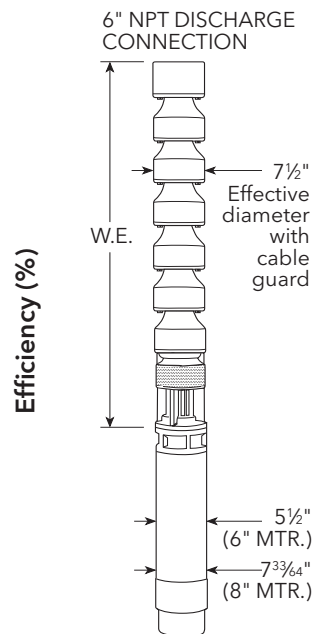
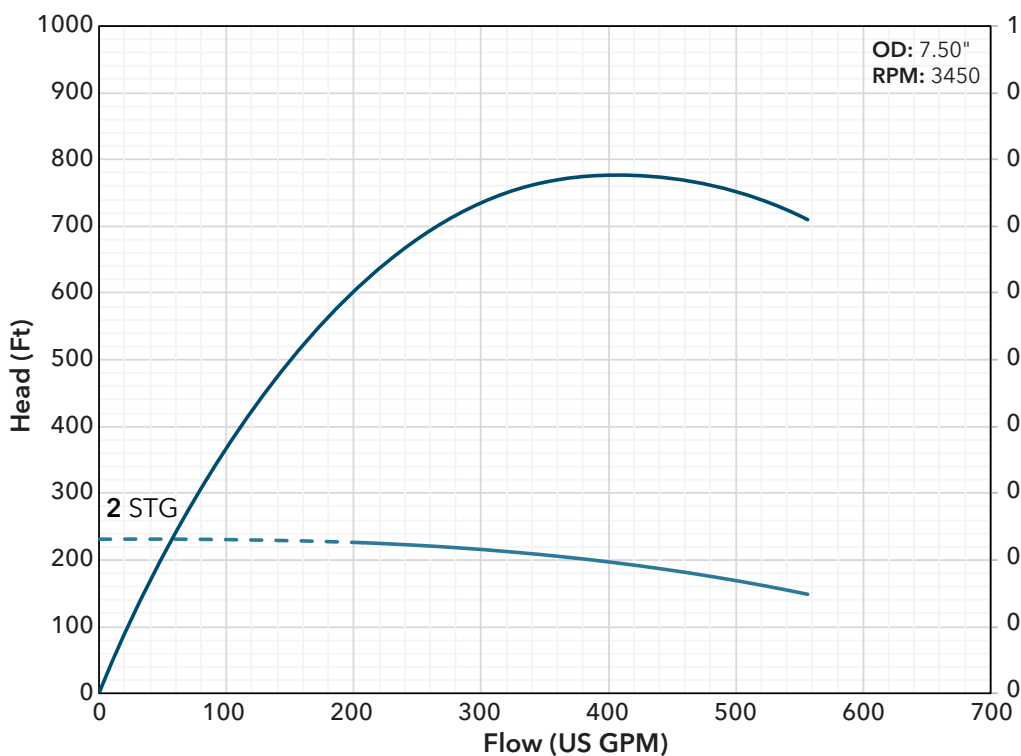

—— Recommended operating range  
 - - - - Alternate pump selection available

Stages	HP	W.E. Length (in)	W.E. Wt. (lbs.)	W.E. Model Number	GWT Series Motor PN# (V)				
					200	230	460	575	230/460
2	30	29.3	103	G-07-CHC-02-030-6-6-B	N/A	N/A	6F304	6F305	N/A

**NOTES:**

1. Dimensions / Weights are not for construction purposes.
2. To use pre-configured model number, no changes are allowed with the exception of impeller trim.
3. Xylem pumps can be used with multiple motor brands. If no motor is listed, another manufacturer's is likely available, consult the submersible turbine pricebook (PTURBVS) for a complete list
4. Configuration shown is equipped with trimmed impellers as standard to remain below NOL hp.

**IMPELLER MODEL:** 7TLC

**BEP FLOW:** 540 GPM

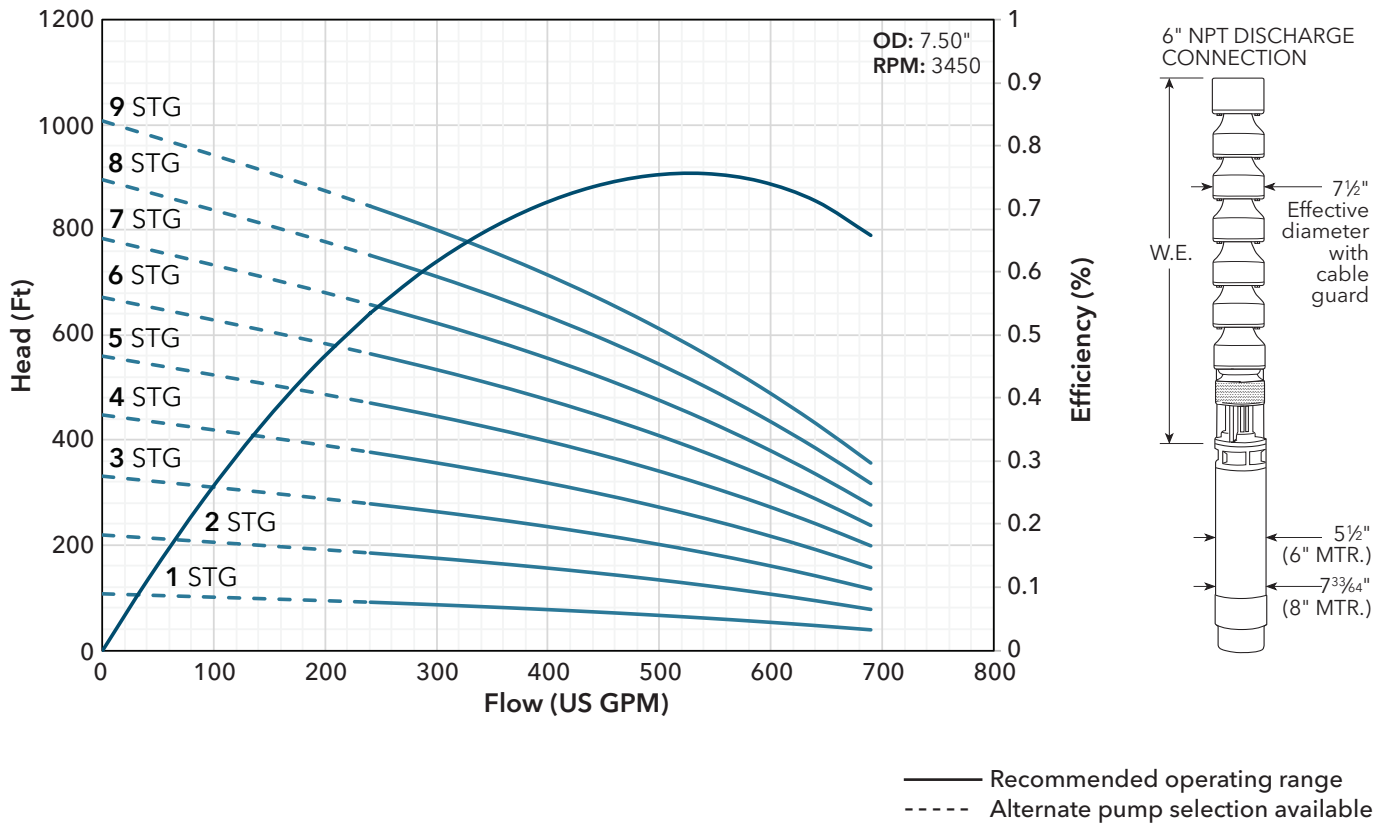

Stages	HP	W.E. Length (in)	W.E Wt. (lbs.)	W.E. Model Number	GWT Series Motor PN# (V)				
					200	230	460	575	230/460
1	15	23.6	78	G-07-TLC-01-015-6-6-B	6F158	6F151	6F154	6F155	6F1524
2	25	30.7	109	G-07-TLC-02-025-6-6-B	6F258	6F252	6F254	6F255	6F2524
3	40	37.8	140	G-07-TLC-03-040-6-6-B	N/A	N/A	6F404	6F405	N/A
4	50	44.9	171	G-07-TLC-04-050-6-6-B	N/A	N/A	6F504	6F505	N/A
5	60	52	202	G-07-TLC-05-060-6-6-B	N/A	N/A	86F604	86F605	N/A
6	75	59.1	233	G-07-TLC-06-075-8-6-B	N/A	N/A	8F754	8F755	N/A
7	100	67.1	276	G-07-TLC-07-100-8-6-B	N/A	N/A	8F1004	8F1005	N/A
8	100	74.2	307	G-07-TLC-08-100-8-6-B	N/A	N/A	8F1004	8F1005	N/A
9	100	81.3	338	G-07-TLC-09-100-8-6-B	N/A	N/A	8F1004	8F1005	N/A

**NOTES:**

1. Dimensions / Weights are not for construction purposes.
2. To use pre-configured model number, no changes are allowed with the exception of impeller trim.
3. Xylem pumps can be used with multiple motor brands. If no motor is listed, another manufacturer's is likely available, consult the submersible turbine pricebook (PTURBVS) for a complete list.

**IMPELLER MODEL:** 7TLC Trimmed

**BEP FLOW:** 540 GPM

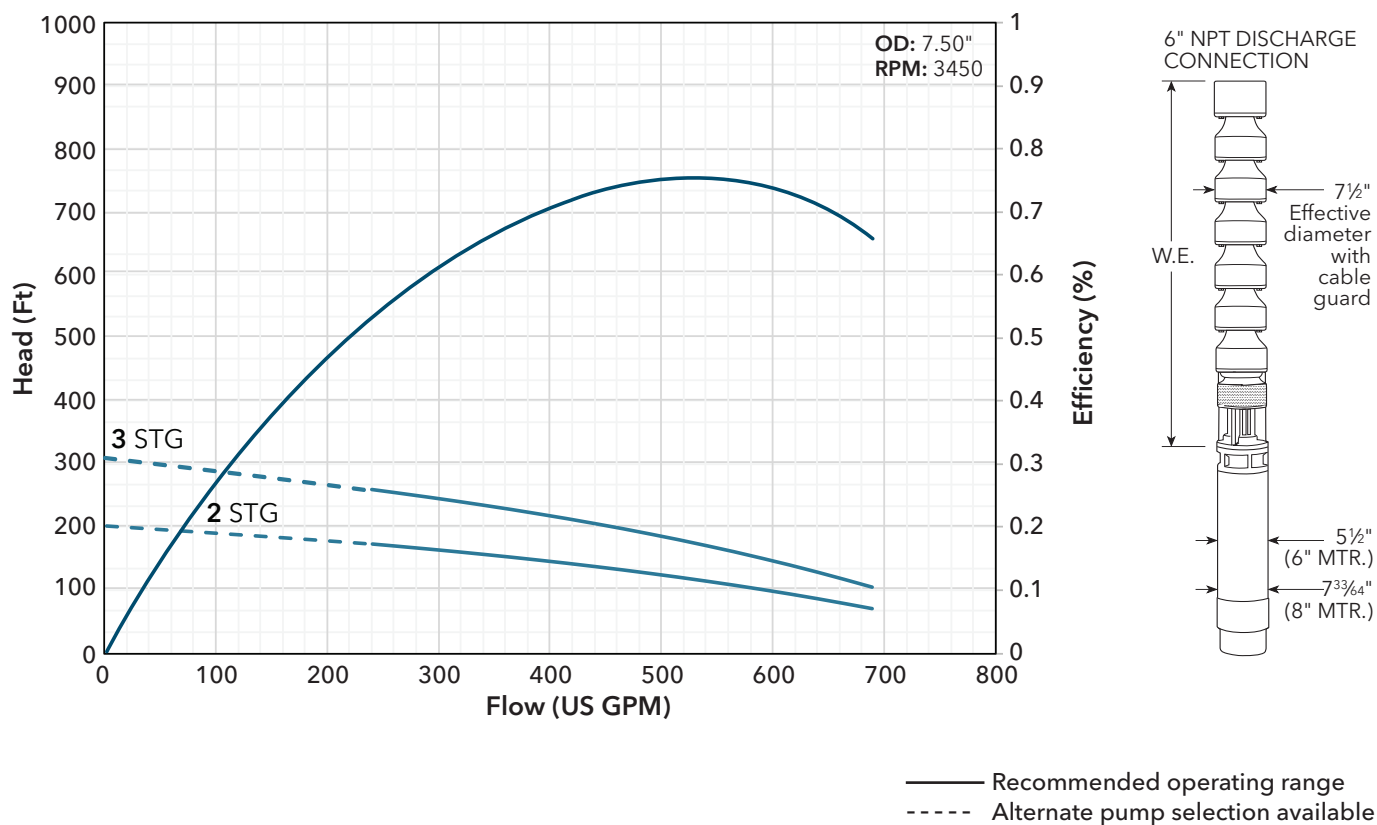

Stages	HP	W.E. Length (in)	W.E. Wt. (lbs.)	W.E. Model Number	GWT Series Motor PN# (V)				
					200	230	460	575	230/460
2	20	30.7	109	G-07-TLC-02-020-6-6-B	6F208	6F202	6F204	6F205	6F2024
3	30	37.8	140	G-07-TLC-03-030-6-6-B	N/A	N/A	6F304	6F305	N/A

**NOTES:**

1. Dimensions / Weights are not for construction purposes.
2. To use pre-configured model number, no changes are allowed with the exception of impeller trim.
3. Xylem pumps can be used with multiple motor brands. If no motor is listed, another manufacturer's is likely available, consult the submersible turbine pricebook (PTURBVS) for a complete list
4. Configuration shown is equipped with trimmed impellers as standard to remain below NOL hp.

**IMPELLER MODEL: 7THC**

**BEP FLOW: 700 GPM**

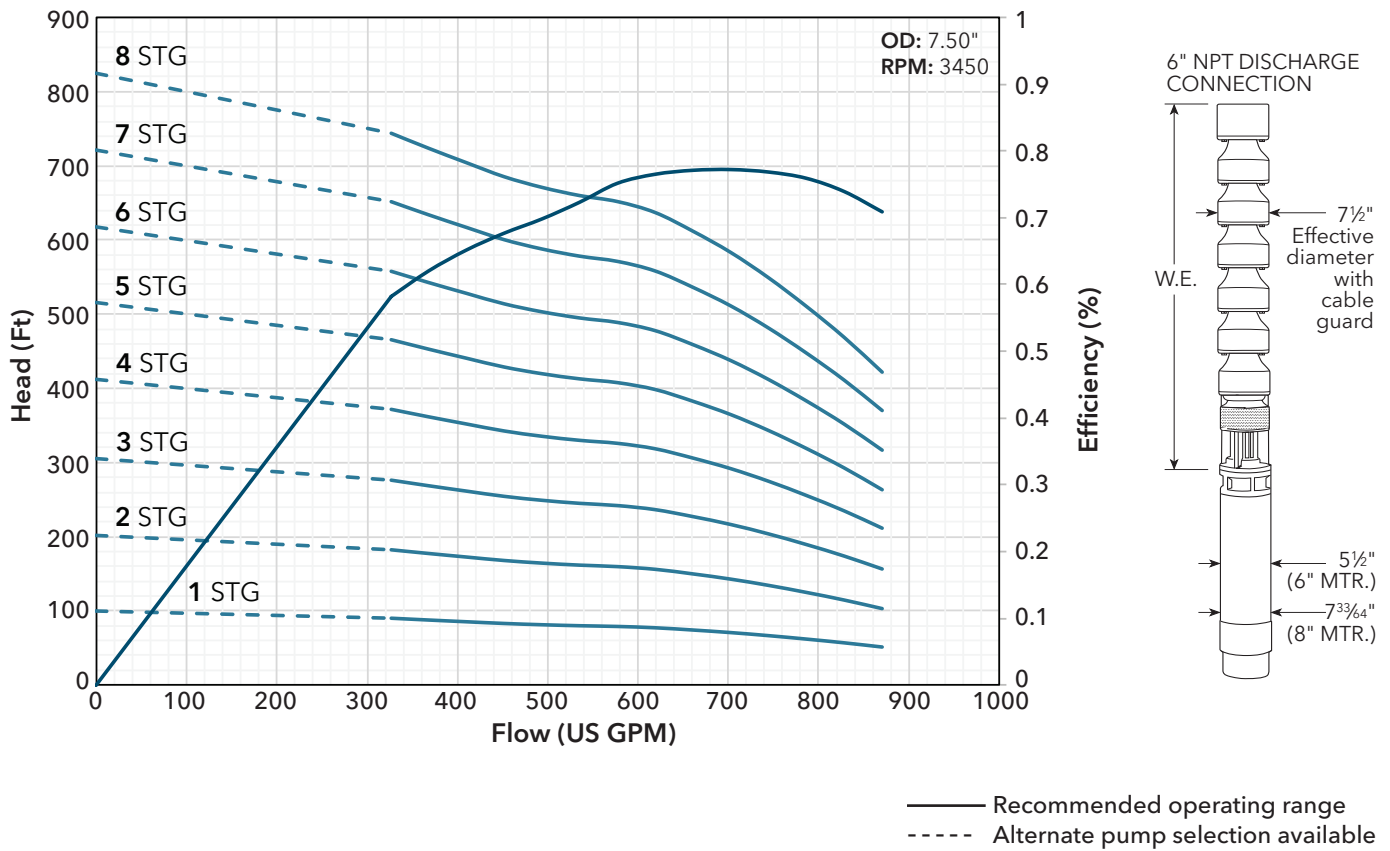

Stages	HP	W.E. Length (in)	W.E. Wt. (lbs.)	W.E. Model Number	GWT Series Motor PN# (V)				
					200	230	460	575	230/460
1	20	23.6	78	G-07-THC-01-020-6-6-B	6F208	6F202	6F204	6F205	6F2024
2	40	30.7	109	G-07-THC-02-040-6-6-B	N/A	N/A	6F404	6F405	N/A
3	50	37.8	140	G-07-THC-03-050-8-6-B	N/A	N/A	6F504	6F505	N/A
4	75	44.9	171	G-07-THC-04-075-8-6-B	N/A	N/A	8F754	8F755	N/A
5	100	52.9	214	G-07-THC-05-100-8-6-B	N/A	N/A	8F1004	8F1005	N/A
6	100	60	245	G-07-THC-06-100-8-6-B	N/A	N/A	8F1004	8F1005	N/A
7	125	67.1	276	G-07-THC-07-125-8-6-B	N/A	N/A	8F1254	8F1255	N/A
8	150	74.2	307	G-07-THC-08-150-8-6-B	N/A	N/A	8F1504	8F1505	N/A

**NOTES:**

1. Dimensions / Weights are not for construction purposes.
2. To use pre-configured model number, no changes are allowed with the exception of impeller trim.
3. Xylem pumps can be used with multiple motor brands. If no motor is listed, another manufacturer's is likely available, consult the submersible turbine pricebook (PTURBVS) for a complete list.

**IMPELLER MODEL:** 7THC Trimmed

**BEP FLOW:** 675 GPM

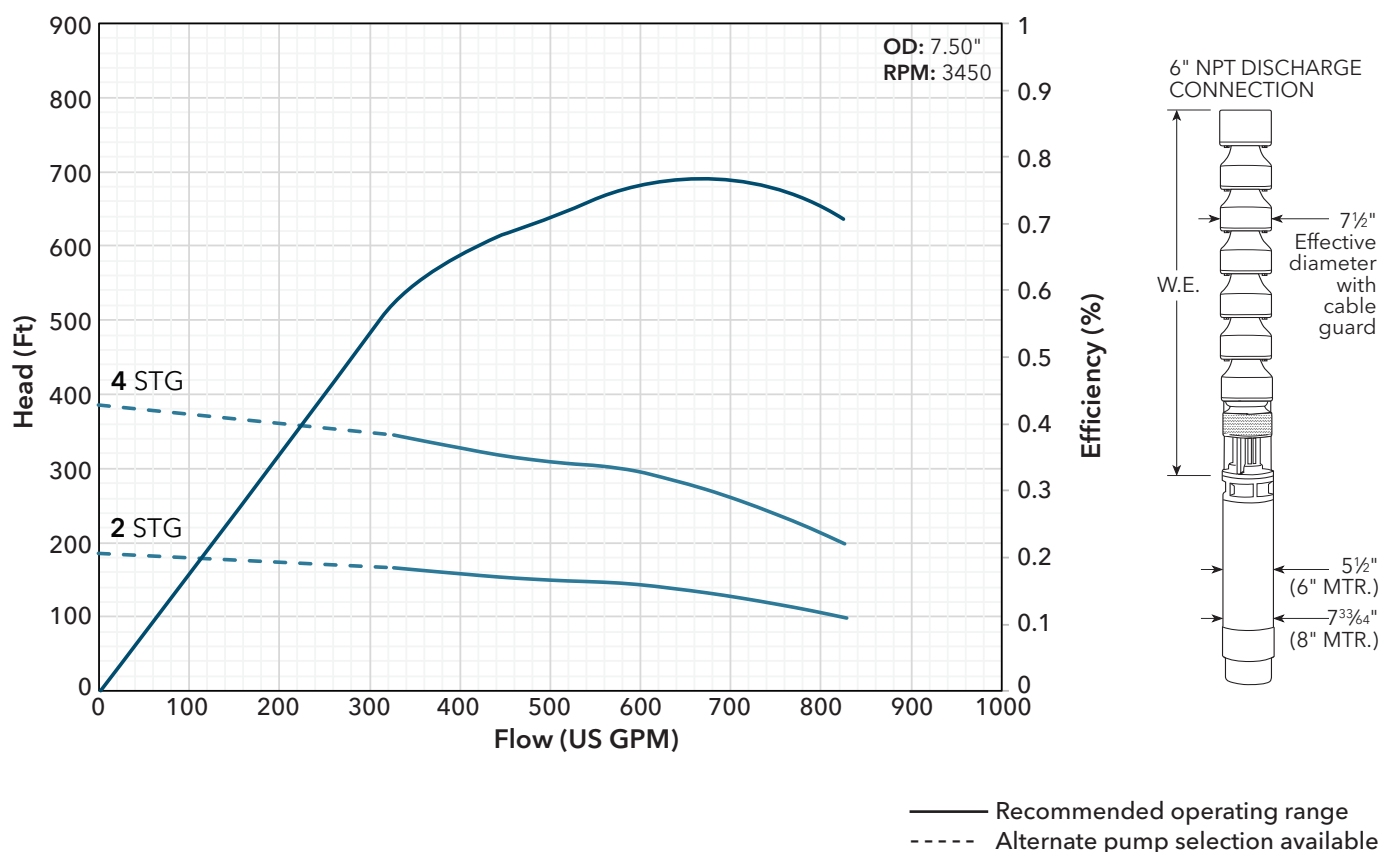

Stages	HP	W.E. Length (in)	W.E. Wt. (lbs.)	W.E. Model Number	GWT Series Motor PN# (V)				
					200	230	460	575	230/460
2	30	30.7	109	G-07-THC-02-030-6-6-B	N/A	N/A	6F304	6F305	N/A
4	60	44.9	171	G-07-THC-04-060-8-6-B	N/A	N/A	86F604	86F605	N/A

**NOTES:**

1. Dimensions / Weights are not for construction purposes.
2. To use pre-configured model number, no changes are allowed with the exception of impeller trim.
3. Xylem pumps can be used with multiple motor brands. If no motor is listed, another manufacturer's is likely available, consult the submersible turbine pricebook (PTURBVS) for a complete list
4. Configuration shown is equipped with trimmed impellers as standard to remain below NOL hp.

## Turbine

**IMPELLER MODEL: 8RJLC**

**BEP FLOW: 487 GPM**

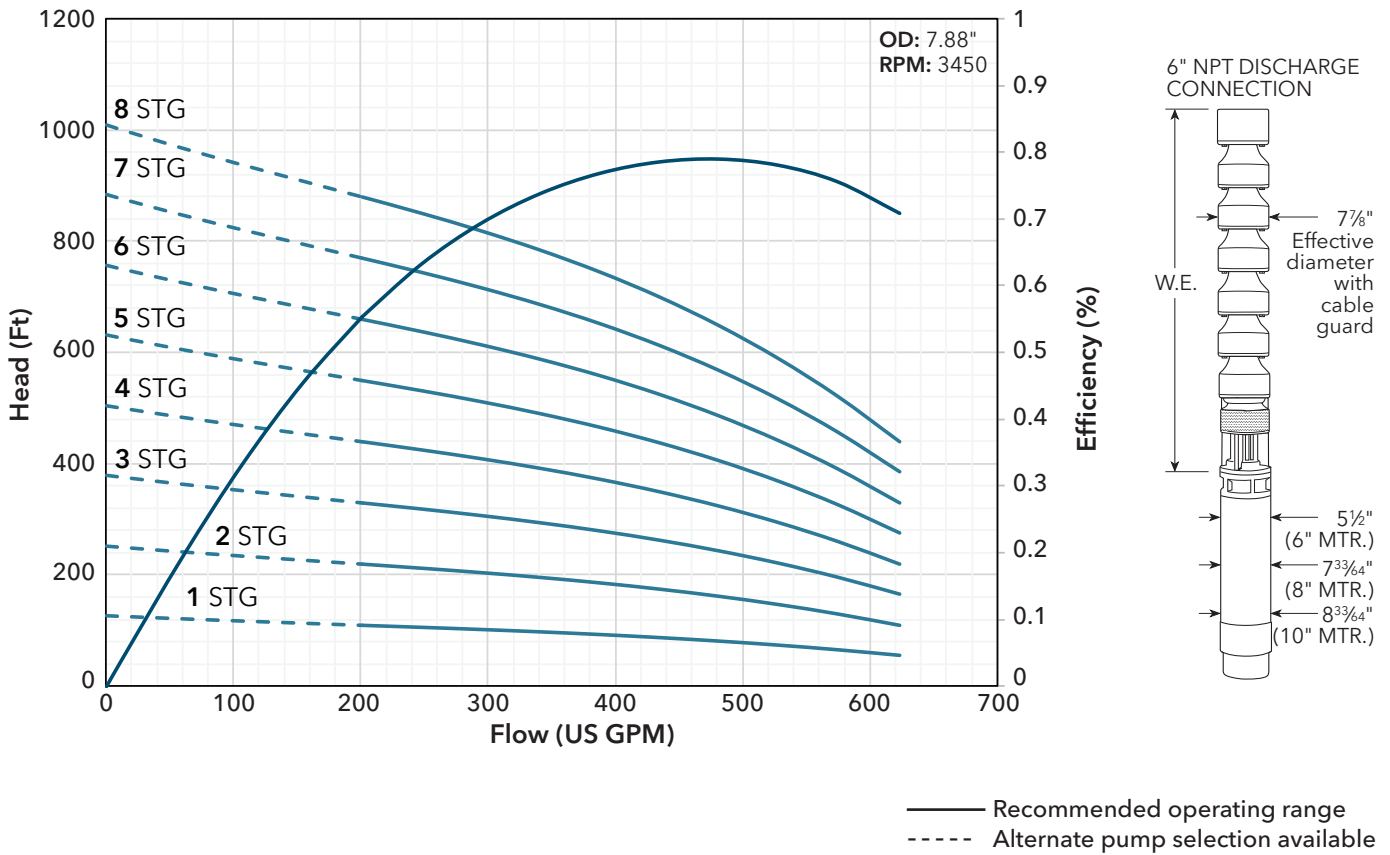

Stages	HP	W.E. Length (in)	W.E. Wt. (lbs.)	W.E. Model Number	GWT Series Motor PN# (V)				
					200	230	460	575	230/460
1	15	23	90	G-08-JLC-01-015-6-6-B	6F158	6F151	6F154	6F155	6F1524
2	25	29.5	124	G-08-JLC-02-025-6-6-B	6F258	6F252	6F254	6F255	6F2524
2	30	29.5	124	G-08-JLC-02-030-6-6-B	6F308	6F302	6F304	6F305	6F3024
3	40	36	258	G-08-JLC-03-040-6-6-B	N/A	N/A	6F404	6F405	N/A
4	50	42.5	292	G-08-JLC-04-050-8-6-B	N/A	N/A	8F504	8F505	N/A
4	60	42.5	292	G-08-JLC-04-060-8-6-B	N/A	N/A	86F604	86F605	N/A
5	75	49	326	G-08-JLC-05-075-8-6-B	N/A	N/A	8F754	8F755	N/A
6	75	63.7	272	G-08-JLC-06-075-8-6-B	N/A	N/A	8F754	8F755	N/A
6	100	63.7	272	G-08-JLC-06-100-8-6-B	N/A	N/A	8F1004	8F1005	N/A
7	100	70.2	306	G-08-JLC-07-100-8-6-B	N/A	N/A	8F1004	8F1005	N/A
8	100	76.7	340	G-08-JLC-08-100-8-6-B	N/A	N/A	8F1004	8F1005	N/A
8	125	76.7	340	G-08-JLC-08-125-8-6-B	N/A	N/A	8F1254	8F1255	N/A

**NOTES:**

1. Dimensions / Weights are not for construction purposes.
2. Models are selected to be non-overloading across the duty curve, except for highlighted selections which are non-overloading at the best efficiency duty point but may overload recommended motor size towards runout. Highlighted models stay below 1.15 service factor.
3. To use pre-configured model number, no changes are allowed with the exception of impeller trim.
4. Xylem pumps can be used with multiple motor brands. If no motor is listed, another manufacturer's is likely available, consult the submersible turbine pricebook (PTURBVS) for a complete list.

**IMPELLER MODEL: 8RJHC**

**BEP FLOW: 647 GPM**

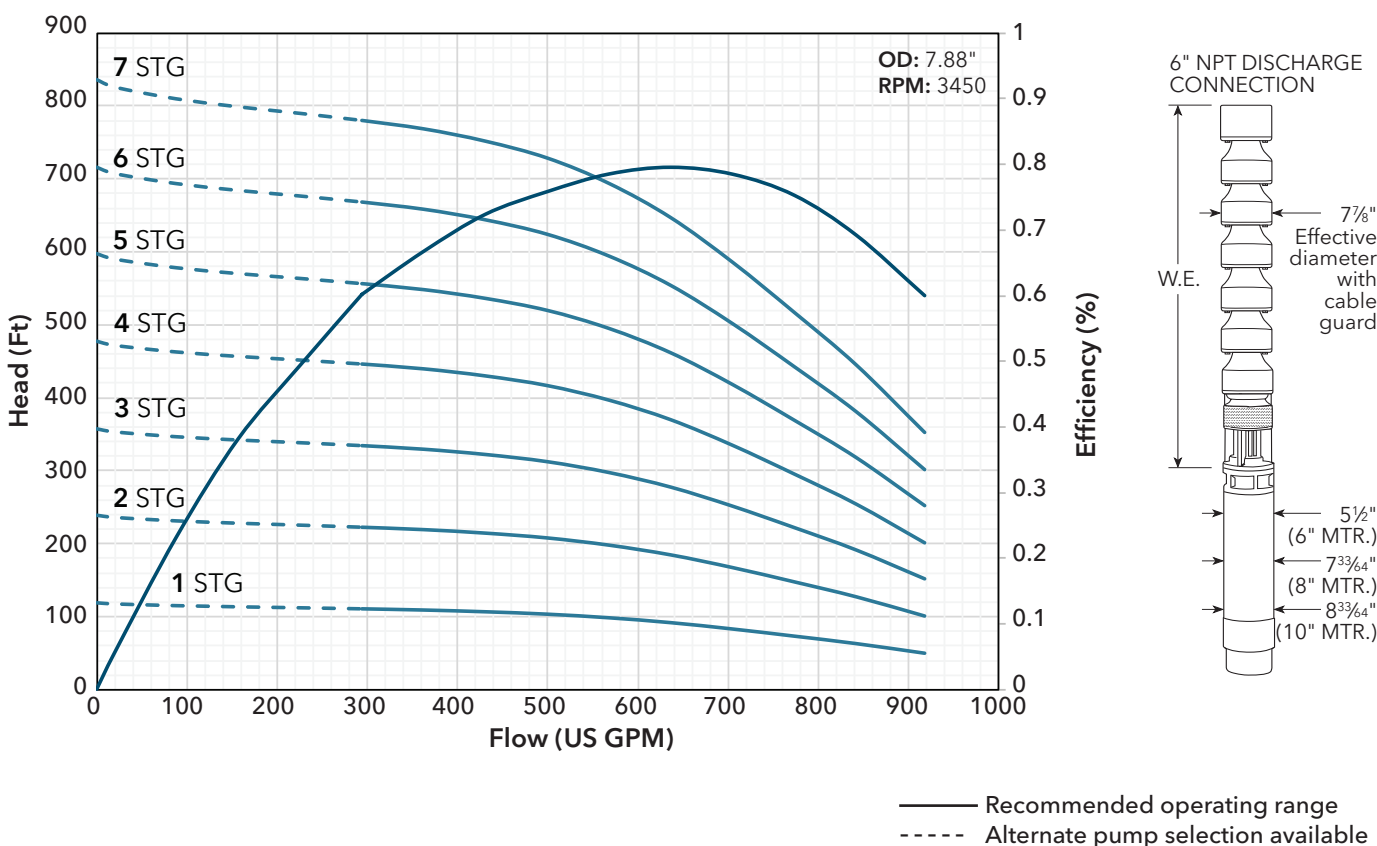

Stages	HP	W.E. Length (in)	W.E. Wt. (lbs.)	W.E. Model Number	GWT Series Motor PN# (V)				
					200	230	460	575	230/460
1	20	23	90	G-08-JHC-01-020-6-6-B	6F208	6F202	6F204	6F205	6F2024
2	40	29.5	124	G-08-JHC-02-040-6-6-B	N/A	N/A	6F404	6F405	N/A
3	60	36	258	G-08-JHC-03-060-8-6-B	N/A	N/A	8F604	8F605	N/A
4	75	50.7	204	G-08-JHC-04-075-8-6-B	N/A	N/A	8F754	8F755	N/A
4	100	50.7	204	G-08-JHC-04-100-8-6-B	N/A	N/A	8F1004	8F1005	N/A
5	100	57.2	238	G-08-JHC-05-100-8-6-B	N/A	N/A	8F1004	8F1005	N/A
6	125	63.7	272	G-08-JHC-06-125-8-6-B	N/A	N/A	8F1254	8F1255	N/A
7	150	70.2	306	G-08-JHC-07-150-8-6-B	N/A	N/A	8F1504	8F1505	N/A

**NOTES:**

1. Dimensions / Weights are not for construction purposes.
2. Models are selected to be non-overloading across the duty curve, except for highlighted selections which are non-overloading at the best efficiency duty point but may overload recommended motor size towards runout. Highlighted models stay below 1.15 service factor.
3. To use pre-configured model number, no changes are allowed with the exception of impeller trim.
4. Xylem pumps can be used with multiple motor brands. If no motor is listed, another manufacturer's is likely available, consult the submersible turbine pricebook (PTURBVS) for a complete list.

## Turbine

**IMPELLER MODEL:** 8RJHC Trimmed

**BEP FLOW:** 567 GPM

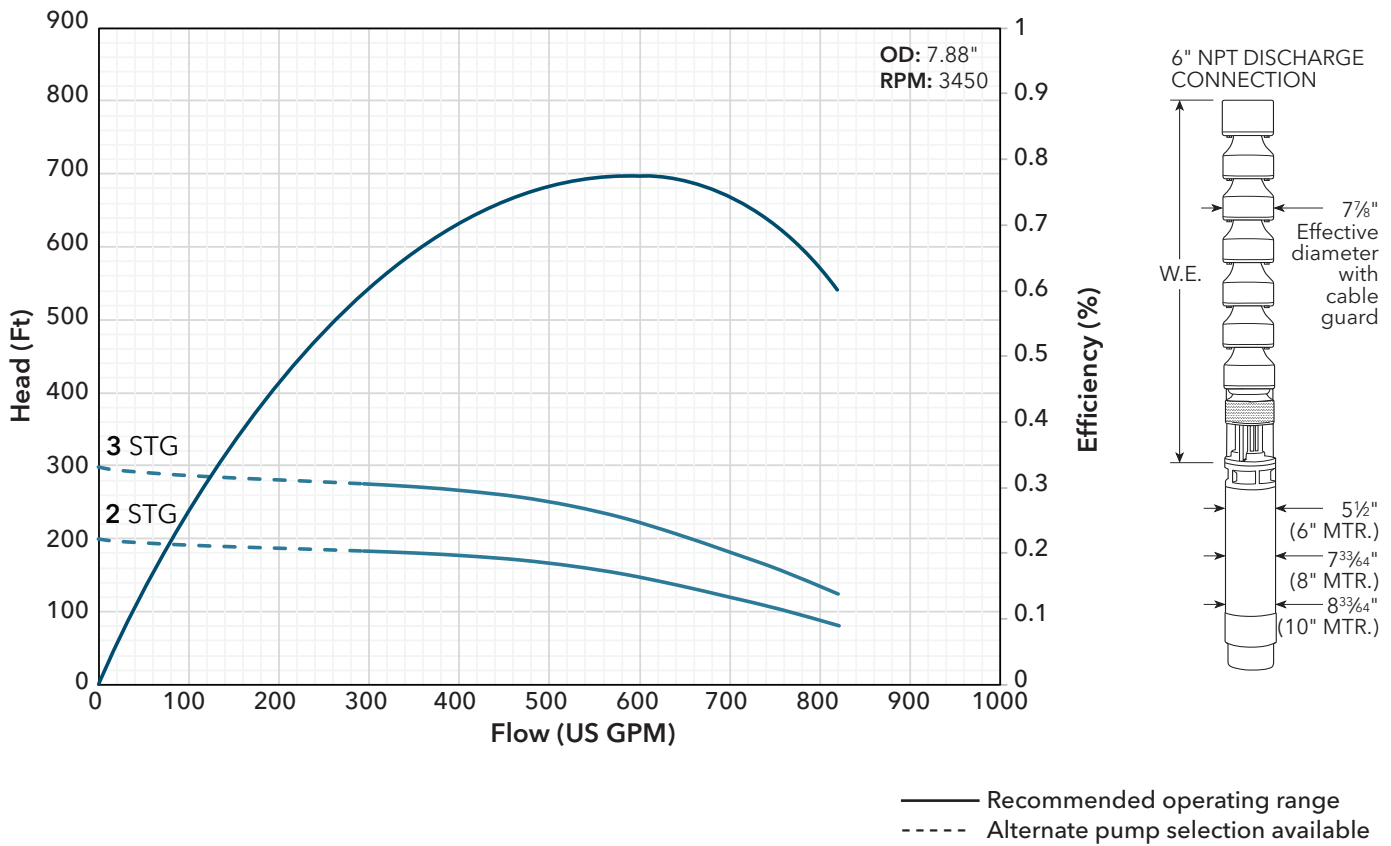

Stages	HP	W.E. Length (in)	W.E. Wt. (lbs.)	W.E. Model Number	GWT Series Motor PN# (V)				
					200	230	460	575	230/460
2	30	29.5	124	G-08-JHC-02-030-6-6-B	N/A	N/A	6F304	6F305	N/A
3	50	36	258	G-08-JHC-03-050-8-6-B	N/A	N/A	6F504	6F505	N/A

**NOTES:**

1. Dimensions / Weights are not for construction purposes.
2. To use pre-configured model number, no changes are allowed with the exception of impeller trim.
3. Xylem pumps can be used with multiple motor brands. If no motor is listed, another manufacturer's is likely available, consult the submersible turbine pricebook (PTURBVS) for a complete list
4. Configuration shown is equipped with trimmed impellers as standard to remain below NOL hp.



**IMPELLER MODEL:** 9WALC

**BEP FLOW:** 370 GPM

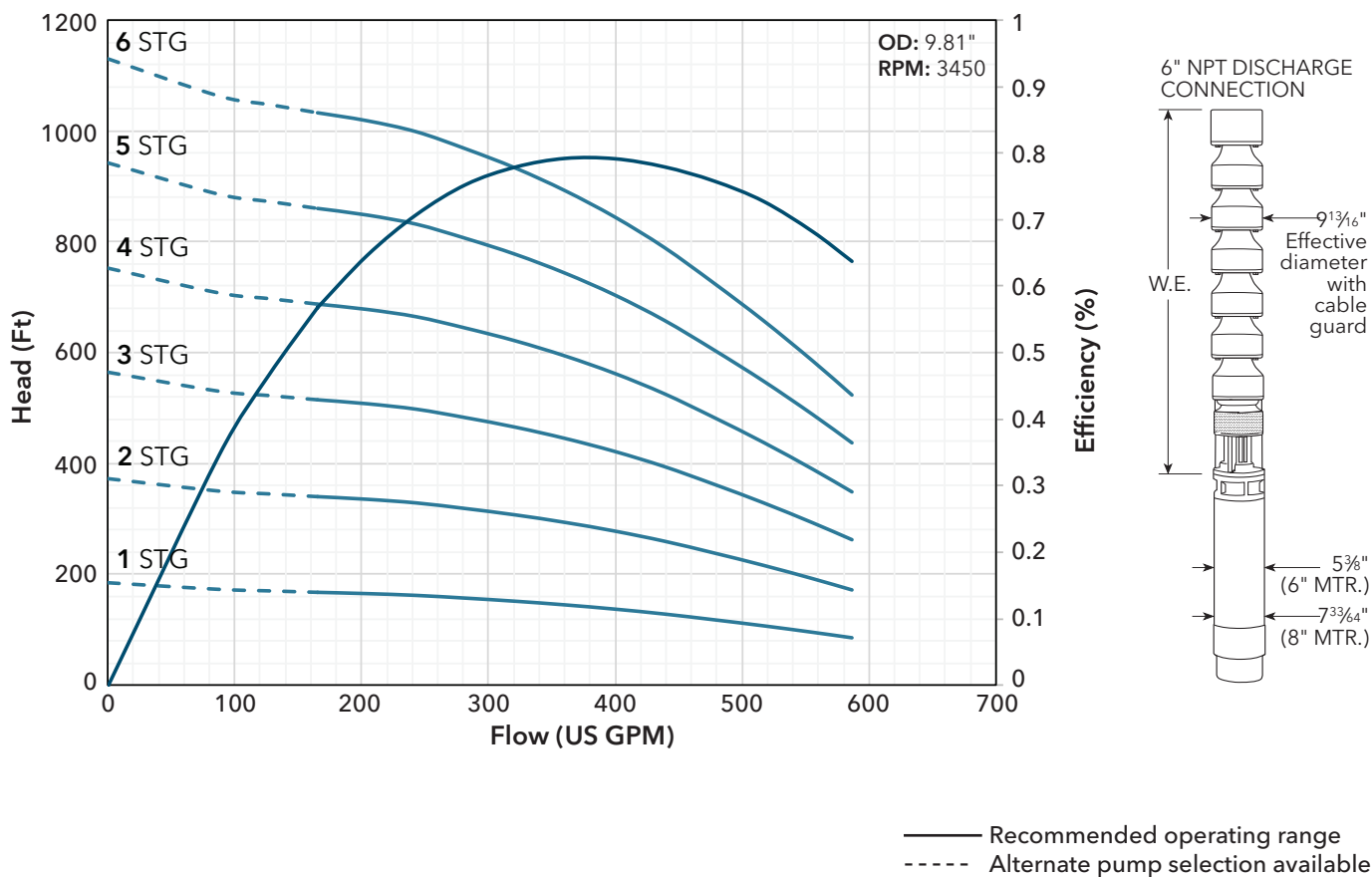

Stages	HP	W.E. Length (in)	W.E Wt. (lbs.)	W.E. Model Number	GWT Series Motor PN# (V)				
					200	230	460	575	230/460
1	20	26.3	158	G-09-WAL-01-020-6-6-B	6F208	6F202	6F204	6F205	6F2024
2	40	32.9	216	G-09-WAL-02-040-6-6-B	N/A	N/A	6F404	6F405	N/A
3	60	39.5	274	G-09-WAL-03-060-8-6-B	N/A	N/A	86F604	86F605	N/A
4	75	46.1	332	G-09-WAL-04-075-8-6-B	N/A	N/A	8F754	8F755	N/A
4	100	46.1	332	G-09-WAL-04-100-8-6-B	N/A	N/A	8F1004	8F1005	N/A
5	100	50.9	402	G-09-WAL-05-100-8-6-B	N/A	N/A	8F1004	8F1005	N/A
6	125	57.5	460	G-09-WAL-06-125-8-6-B	N/A	N/A	8F1254	8F1255	N/A

**NOTES:**

1. Dimensions / Weights are not for construction purposes.
2. Models are selected to be non-overloading across the duty curve, except for highlighted selections which are non-overloading at the best efficiency duty point but may overload recommended motor size towards runout. Highlighted models stay below 1.15 service factor.
3. To use pre-configured model number, no changes are allowed with the exception of impeller trim.
4. Xylem pumps can be used with multiple motor brands. If no motor is listed, another manufacturer's is likely available, consult the submersible turbine pricebook (PTURBVS) for a complete list.

**IMPELLER MODEL:** 9WALC Trimmed

**BEP FLOW:** 368 GPM

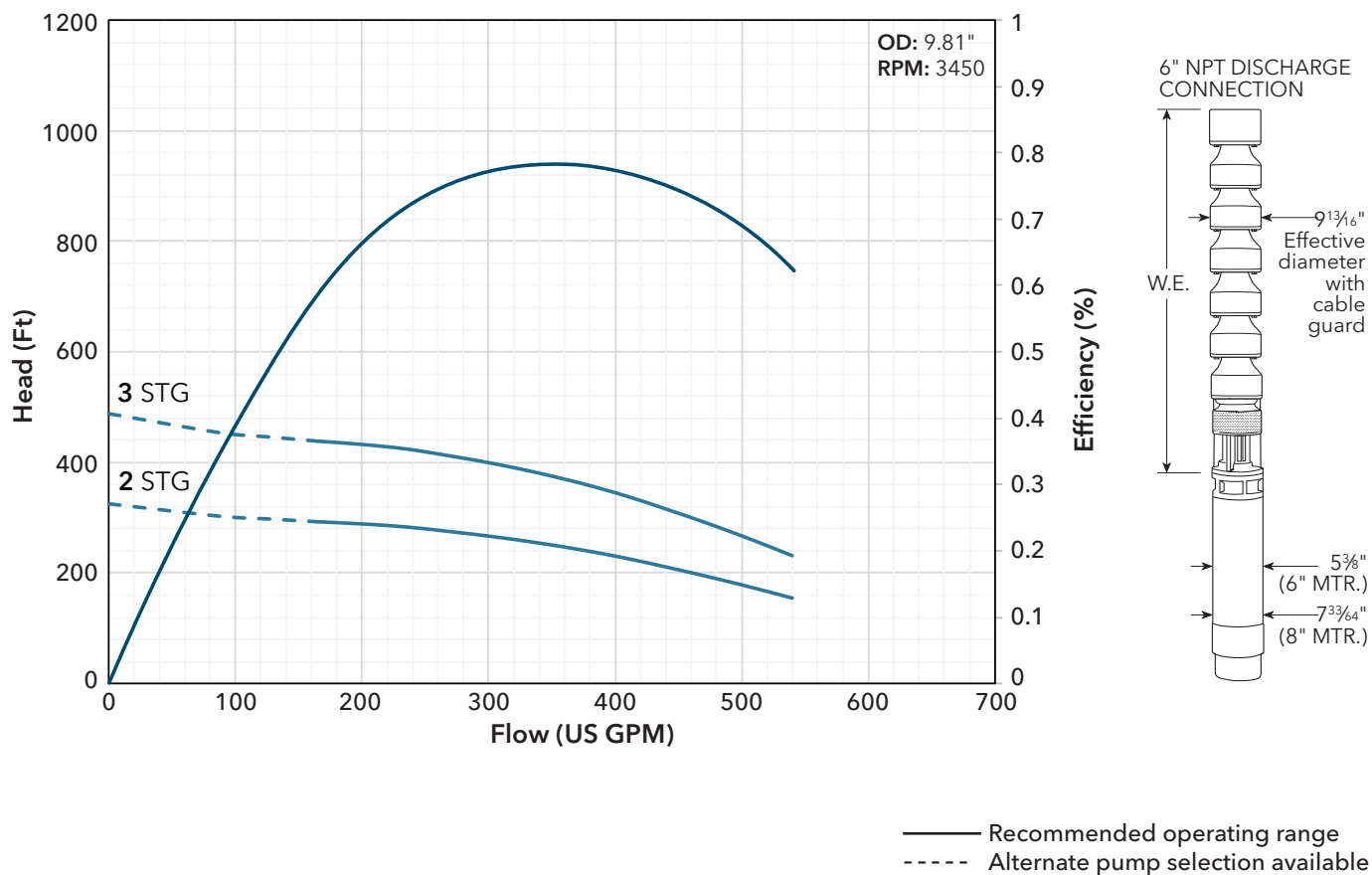

Stages	HP	W.E. Length (in)	W.E Wt. (lbs.)	W.E. Model Number	GWT Series Motor PN# (V)				
					200	230	460	575	230/460
2	30	32.9	216	G-09-WAL-02-030-6-6-B	N/A	N/A	6F304	6F305	N/A
3	50	39.5	274	G-09-WAL-03-050-8-6-B	N/A	N/A	6F504	6F505	N/A

**NOTES:**

1. Dimensions / Weights are not for construction purposes.
2. To use pre-configured model number, no changes are allowed with the exception of impeller trim.
3. Xylem pumps can be used with multiple motor brands. If no motor is listed, another manufacturer's is likely available, consult the submersible turbine pricebook (PTURBVS) for a complete list
4. Configuration shown is equipped with trimmed impellers as standard to remain below NOL hp.

## Turbine

**IMPELLER MODEL:** 9WAHC

**BEP FLOW:** 490 GPM

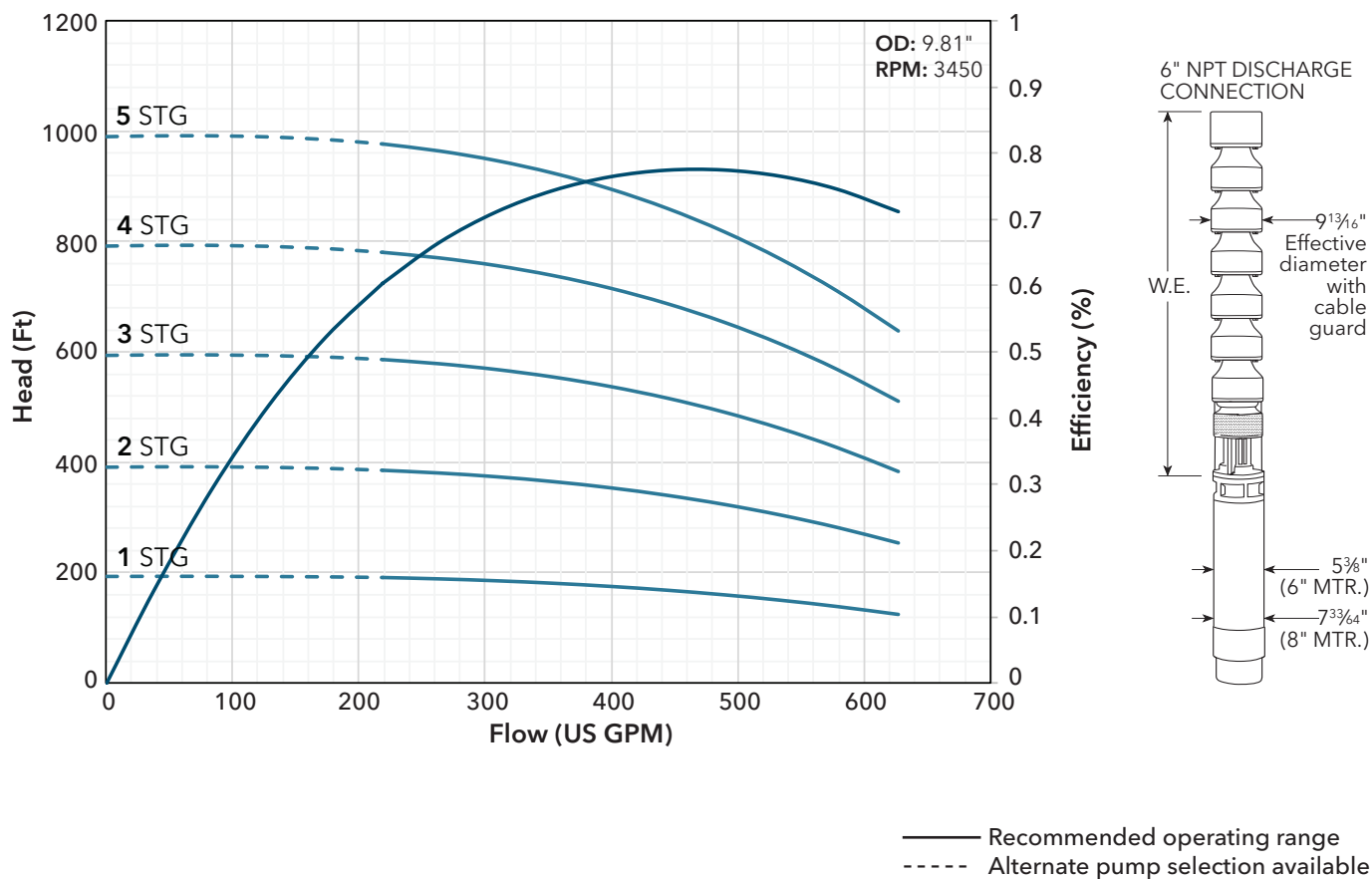

Stages	HP	W.E. Length (in)	W.E Wt. (lbs.)	W.E. Model Number	GWT Series Motor PN# (V)				
					200	230	460	575	230/460
1	30	26.3	158	G-09-WAH-01-030-6-6-B	6F308	6F302	6F304	6F305	6F3024
2	60	32.9	216	G-09-WAH-02-060-8-6-B	N/A	N/A	86F604	86F605	N/A
3	100	39.5	332	G-09-WAH-03-100-8-6-B	N/A	N/A	8F1004	8F1005	N/A
4	125	44.3	344	G-09-WAH-04-125-8-6-B	N/A	N/A	8F1254	8F1255	N/A
5	150	50.9	402	G-09-WAH-05-150-8-6-B	N/A	N/A	8F1504	8F1505	N/A

**NOTES:**

1. Dimensions / Weights are not for construction purposes.
2. To use pre-configured model number, no changes are allowed with the exception of impeller trim.
3. Xylem pumps can be used with multiple motor brands. If no motor is listed, another manufacturer's is likely available, consult the submersible turbine pricebook (PTURBVS) for a complete list.

**IMPELLER MODEL:** 9WAHC Trimmed

**BEP FLOW:** 413 GPM

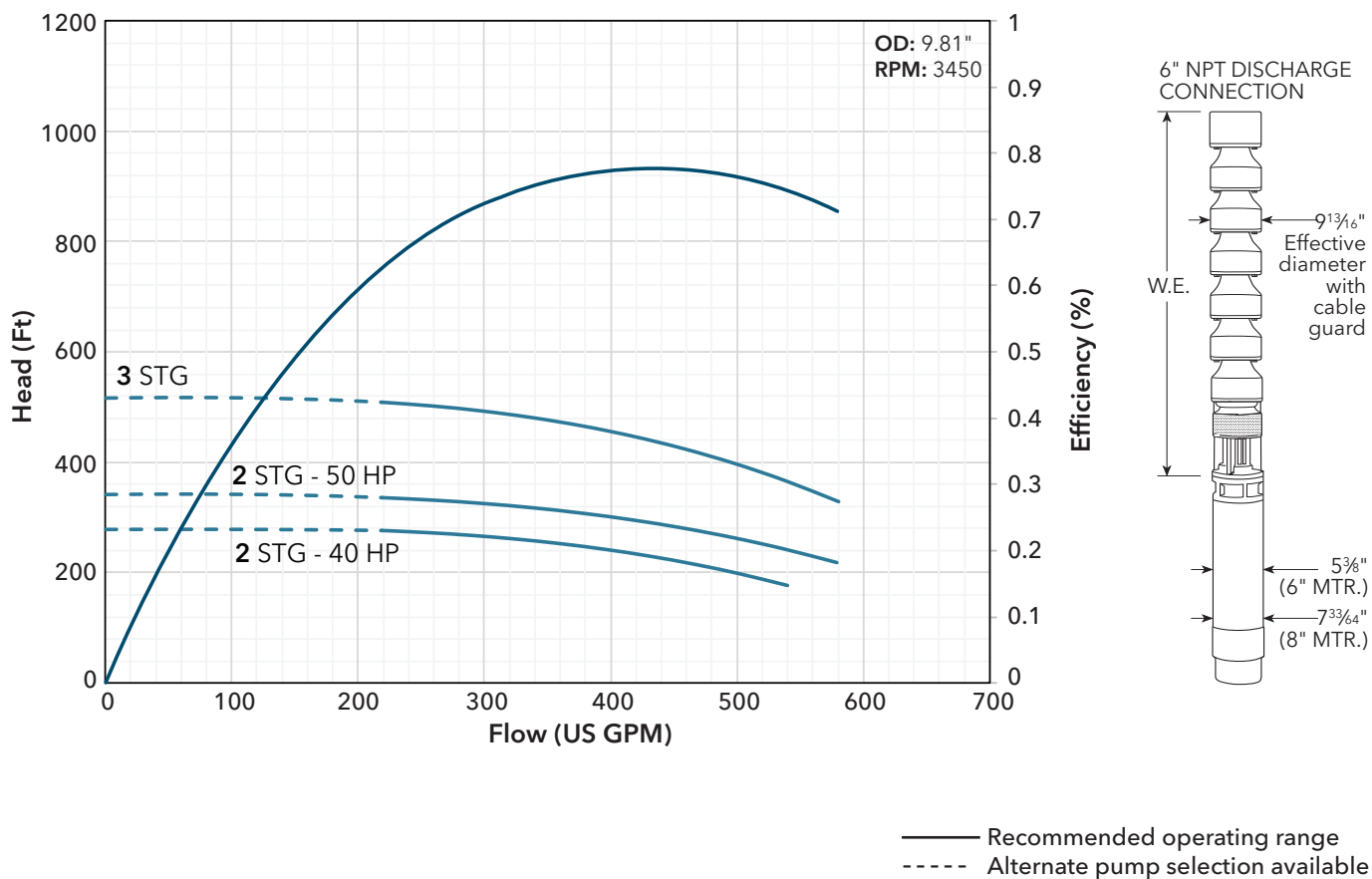

Stages	HP	W.E. Length (in)	W.E. Wt. (lbs.)	W.E. Model Number	GWT Series Motor PN# (V)				
					200	230	460	575	230/460
2	40	32.9	216	G-09-WAH-02-040-8-6-B	N/A	N/A	6F404	6F405	N/A
2	50	32.9	216	G-09-WAH-02-050-8-6-B	N/A	N/A	6F504	6F505	N/A
3	75	39.5	332	G-09-WAH-03-075-8-6-B	N/A	N/A	8F754	8F755	N/A

**NOTES:**

1. Dimensions / Weights are not for construction purposes.
2. To use pre-configured model number, no changes are allowed with the exception of impeller trim.
3. Xylem pumps can be used with multiple motor brands. If no motor is listed, another manufacturer's is likely available, consult the submersible turbine pricebook (PTURBVS) for a complete list
4. Configuration shown is equipped with trimmed impellers as standard to remain below NOL hp.

**IMPELLER MODEL:** 9RCLC

**BEP FLOW:** 858 GPM

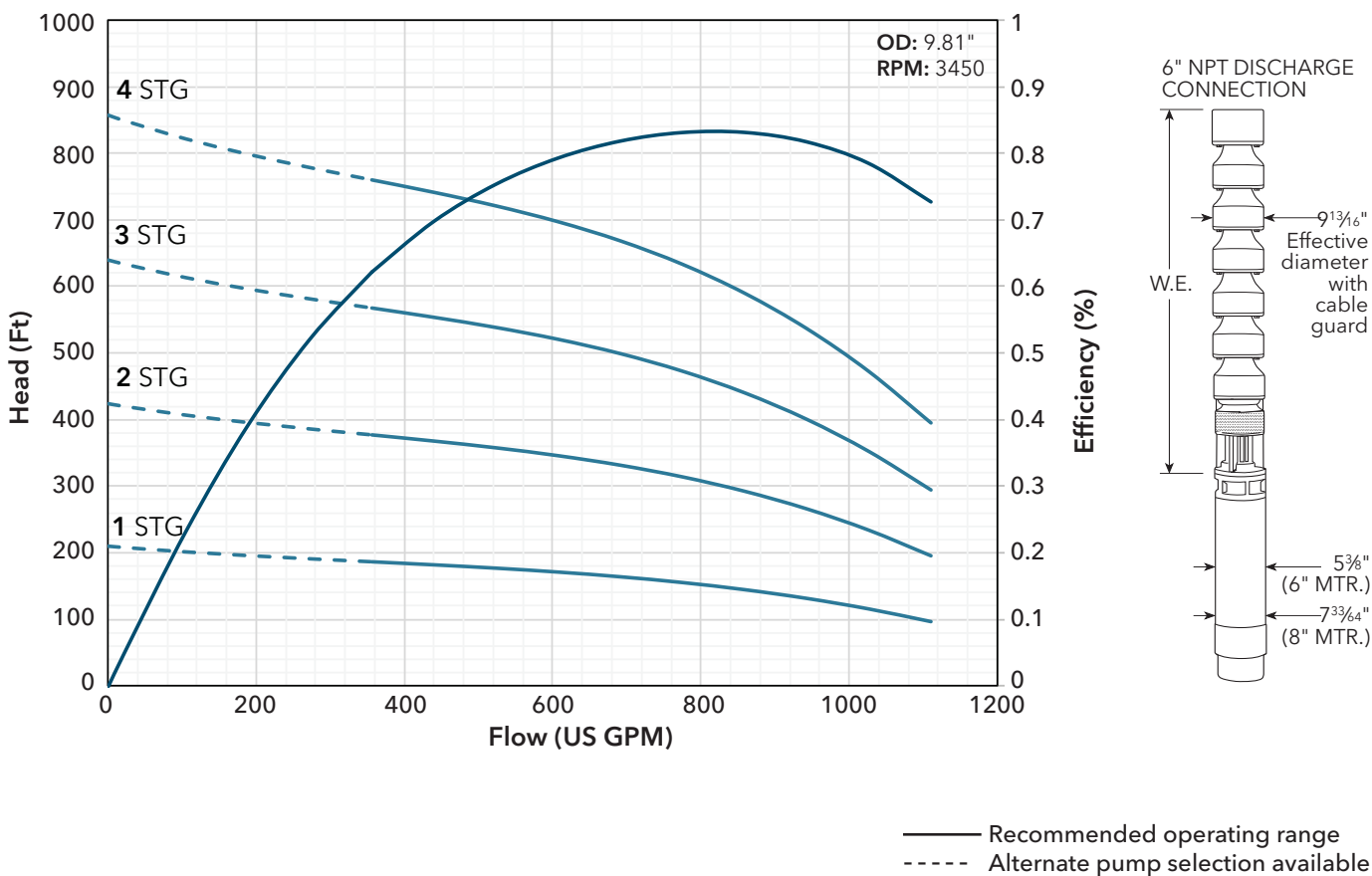

Stages	HP	W.E. Length (in)	W.E Wt. (lbs.)	W.E. Model Number	GWT Series Motor PN# (V)				
					200	230	460	575	230/460
1	40	28	194	G-09-CLC-01-040-6-6-B	N/A	N/A	6F404	6F405	N/A
2	100	36.6	258	G-09-CLC-02-100-8-6-B	N/A	N/A	8F1004	8F1005	N/A
3	125	43.2	334	G-09-CLC-03-125-8-6-B	N/A	N/A	8F1254	8F1255	N/A
4	175	51.8	398	G-09-CLC-04-175-8-6-B	N/A	N/A	N/A	N/A	N/A

**NOTES:**

1. Dimensions / Weights are not for construction purposes.
2. To use pre-configured model number, no changes are allowed with the exception of impeller trim.
3. Xylem pumps can be used with multiple motor brands. If no motor is listed, another manufacturer's is likely available, consult the submersible turbine pricebook (PTURBVS) for a complete list.

## Turbine

**IMPELLER MODEL:** 9RCLC Trimmed

**BEP FLOW:** 743 GPM

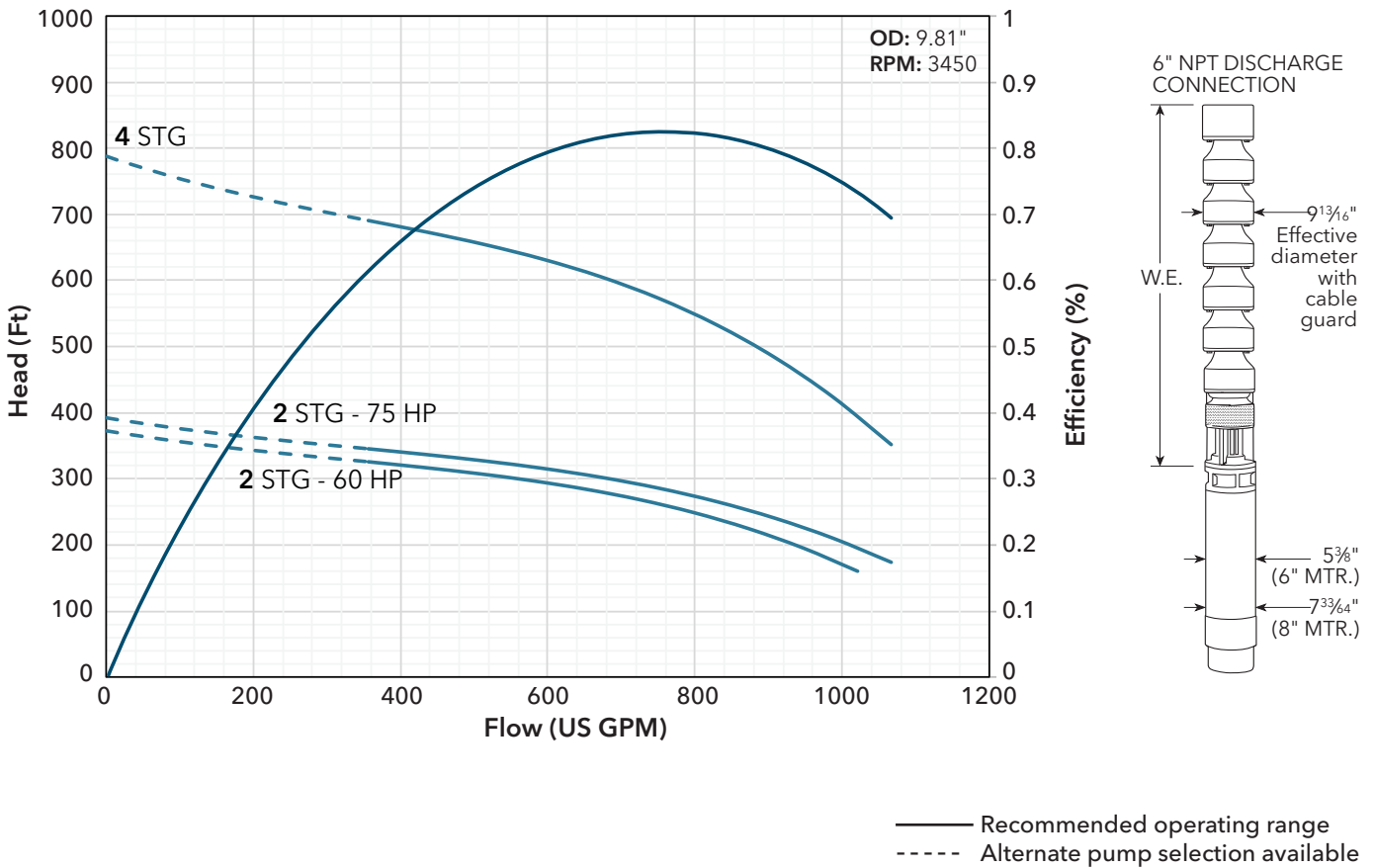

Stages	HP	W.E. Length (in)	W.E Wt. (lbs.)	W.E. Model Number	GWT Series Motor PN# (V)				
					200	230	460	575	230/460
2	60	36.6	258	G-09-CLC-02-060-8-6-B	N/A	N/A	86F604	86F605	N/A
2	75	36.6	258	G-09-CLC-02-075-8-6-B	N/A	N/A	8F754	8F755	N/A
4	150	51.8	398	G-09-CLC-04-150-8-6-B	N/A	N/A	N/A	N/A	N/A

**NOTES:**

1. Dimensions / Weights are not for construction purposes.
2. To use pre-configured model number, no changes are allowed with the exception of impeller trim.
3. Xylem pumps can be used with multiple motor brands. If no motor is listed, another manufacturer's is likely available, consult the submersible turbine pricebook (PTURBVS) for a complete list
4. Configuration shown is equipped with trimmed impellers as standard to remain below NOL hp.

**IMPELLER MODEL: 9RCHC**

**BEP FLOW: 1033 GPM**

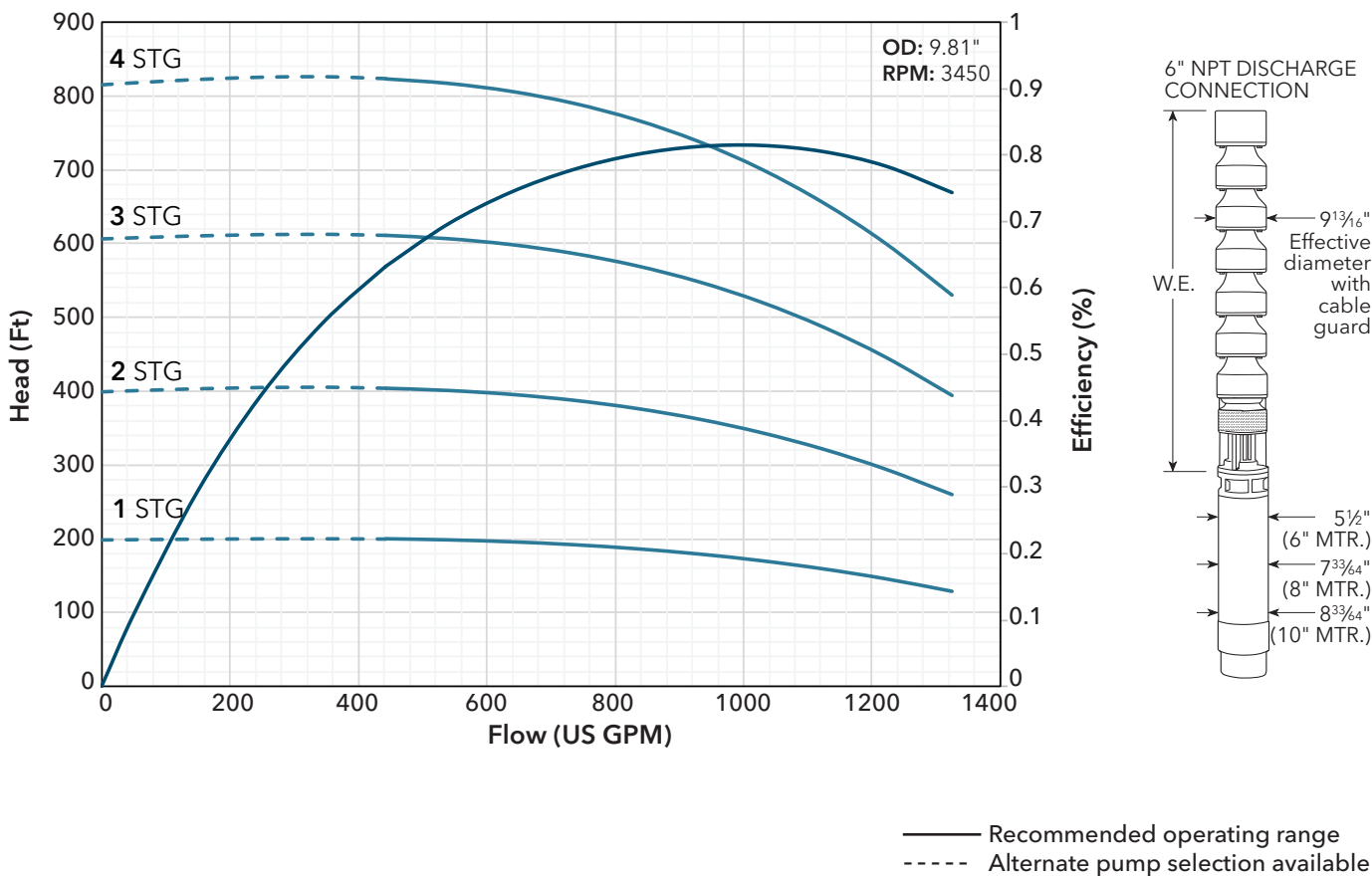

Stages	HP	W.E. Length (in)	W.E Wt. (lbs.)	W.E. Model Number	GWT Series Motor PN# (V)				
					200	230	460	575	230/460
1	60	28	194	G-09-CHC-01-060-8-6-B	N/A	N/A	86F604	86F605	N/A
2	125	34.8	270	G-09-CHC-02-125-8-6-B	N/A	N/A	8F1254	8F1255	N/A
3	175	43.5	334	G-09-CHC-03-175-8-6-B	N/A	N/A	N/A	N/A	N/A
4	250	51.8	398	G-09-CHC-04-250-0-6-B	N/A	N/A	N/A	N/A	N/A

**NOTES:**

1. Dimensions / Weights are not for construction purposes.
2. To use pre-configured model number, no changes are allowed with the exception of impeller trim.
3. Xylem pumps can be used with multiple motor brands. If no motor is listed, another manufacturer's is likely available, consult the submersible turbine pricebook (PTURBVS) for a complete list.

## Turbine

**IMPELLER MODEL:** 9RCHC Trimmed

**BEP FLOW:** 1006 GPM

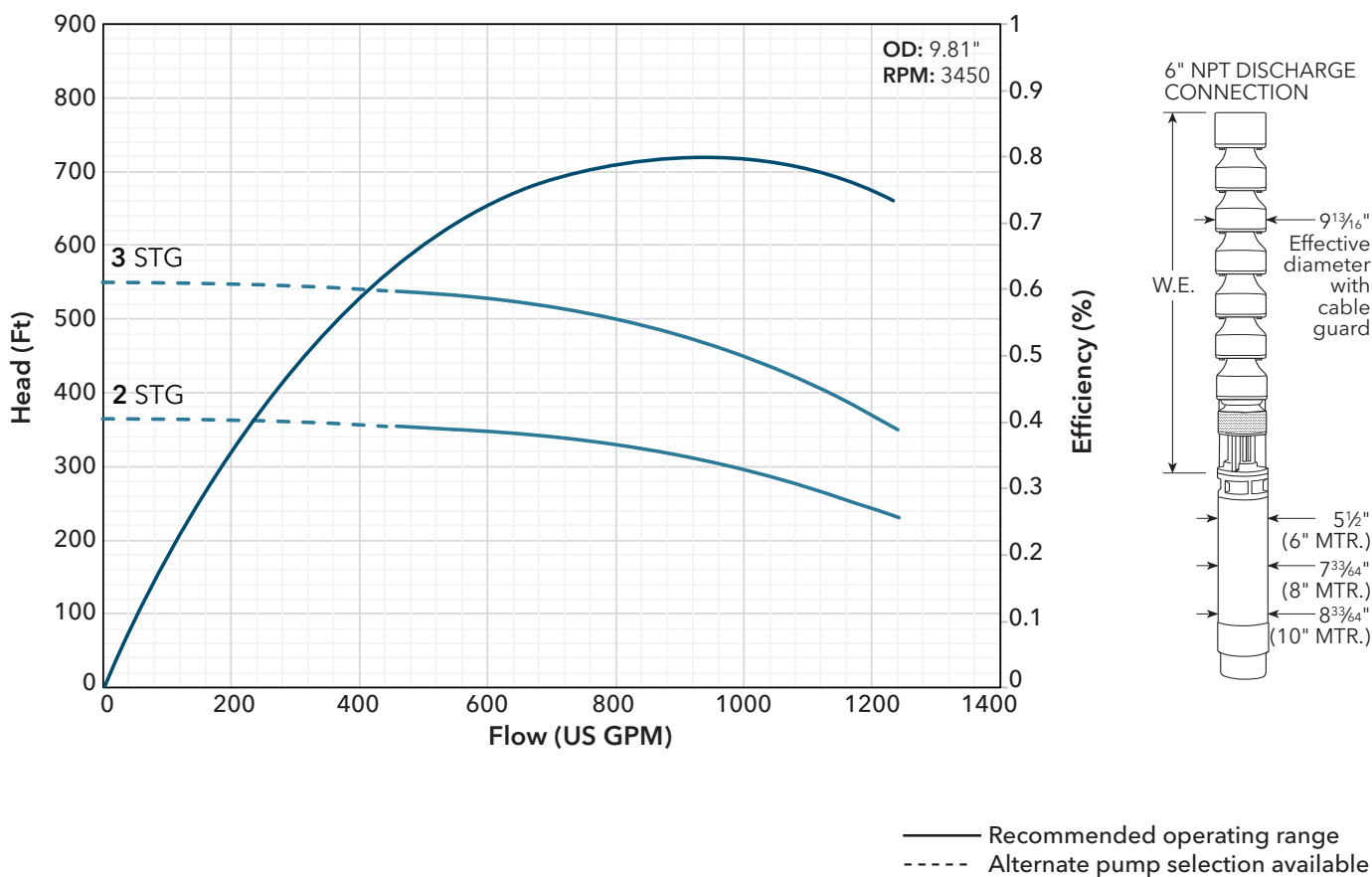

Stages	HP	W.E. Length (in)	W.E Wt. (lbs.)	W.E. Model Number	GWT Series Motor PN# (V)				
					200	230	460	575	230/460
2	100	34.8	270	G-09-CHC-02-100-8-6-B	N/A	N/A	8F1004	8F1005	N/A
3	150	43.5	334	G-09-CHC-03-150-8-6-B	N/A	N/A	N/A	N/A	N/A

**NOTES:**

1. Dimensions / Weights are not for construction purposes.
2. To use pre-configured model number, no changes are allowed with the exception of impeller trim.
3. Xylem pumps can be used with multiple motor brands. If no motor is listed, another manufacturer's is likely available, consult the submersible turbine pricebook (PTURBVS) for a complete list
4. Configuration shown is equipped with trimmed impellers as standard to remain below NOL hp.



**IMPELLER MODEL: 9TLC**

**BEP FLOW: 1156 GPM**

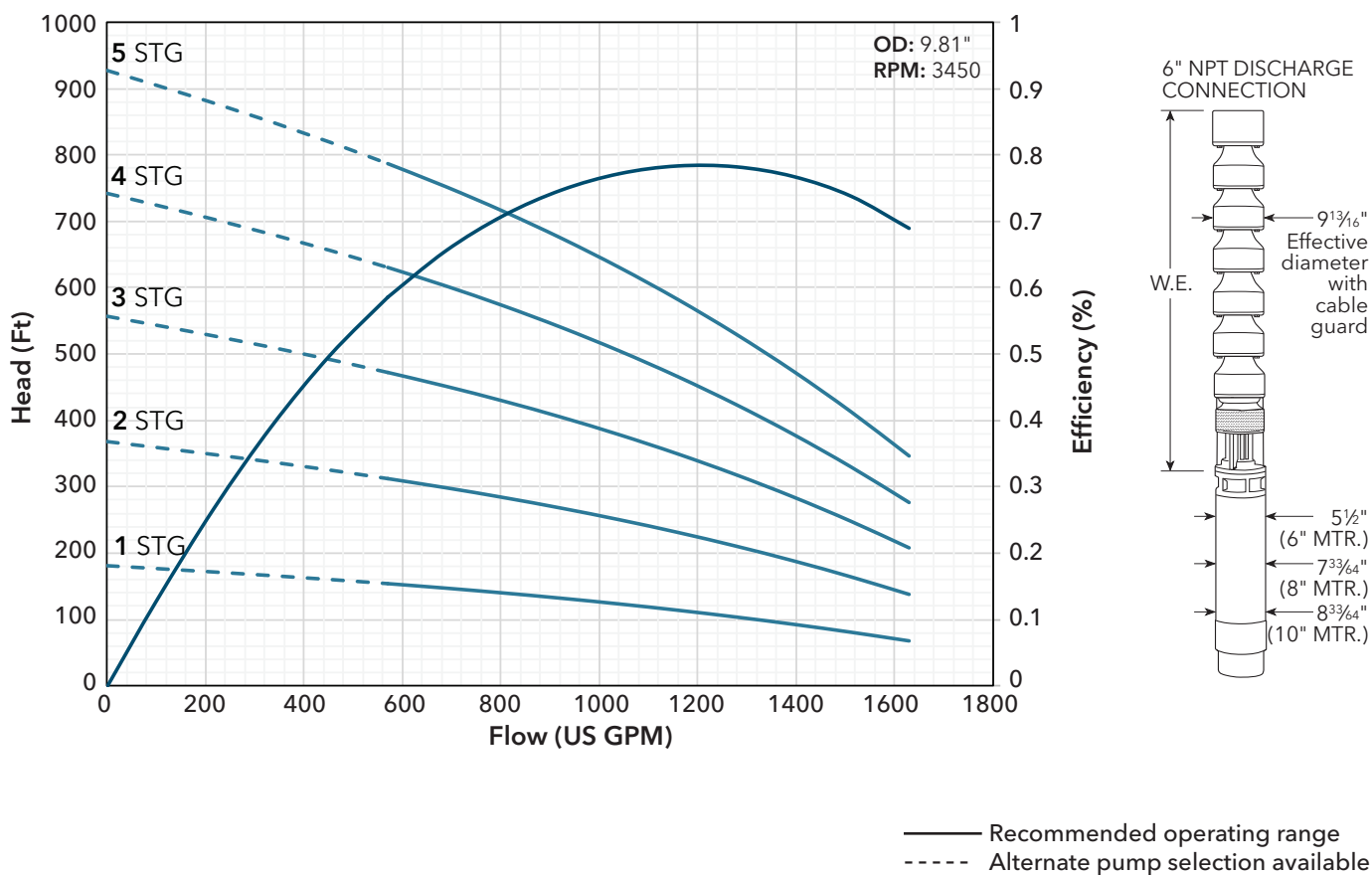

Stages	HP	W.E. Length (in)	W.E Wt. (lbs.)	W.E. Model Number	GWT Series Motor PN# (V)				
					200	230	460	575	230/460
1	50	28	194	G-09-TLC-01-050-8-6-B	N/A	N/A	6F504	6F505	N/A
2	100	34.8	270	G-09-TLC-02-100-8-6-B	N/A	N/A	8F1004	8F1005	N/A
3	150	43.5	334	G-09-TLC-03-150-8-6-B	N/A	N/A	8F1504	8F1505	N/A
4	175	51.8	398	G-09-TLC-04-175-8-6-B	N/A	N/A	N/A	N/A	N/A
5	250	70.1	492	G-09-TLC-05-250-0-6-B	N/A	N/A	N/A	N/A	N/A

**NOTES:**

1. Dimensions / Weights are not for construction purposes.
2. To use pre-configured model number, no changes are allowed with the exception of impeller trim.
3. Xylem pumps can be used with multiple motor brands. If no motor is listed, another manufacturer's is likely available, consult the submersible turbine pricebook (PTURBVS) for a complete list.

**IMPELLER MODEL:** 9TLC Trimmed

**BEP FLOW:** 1226 GPM

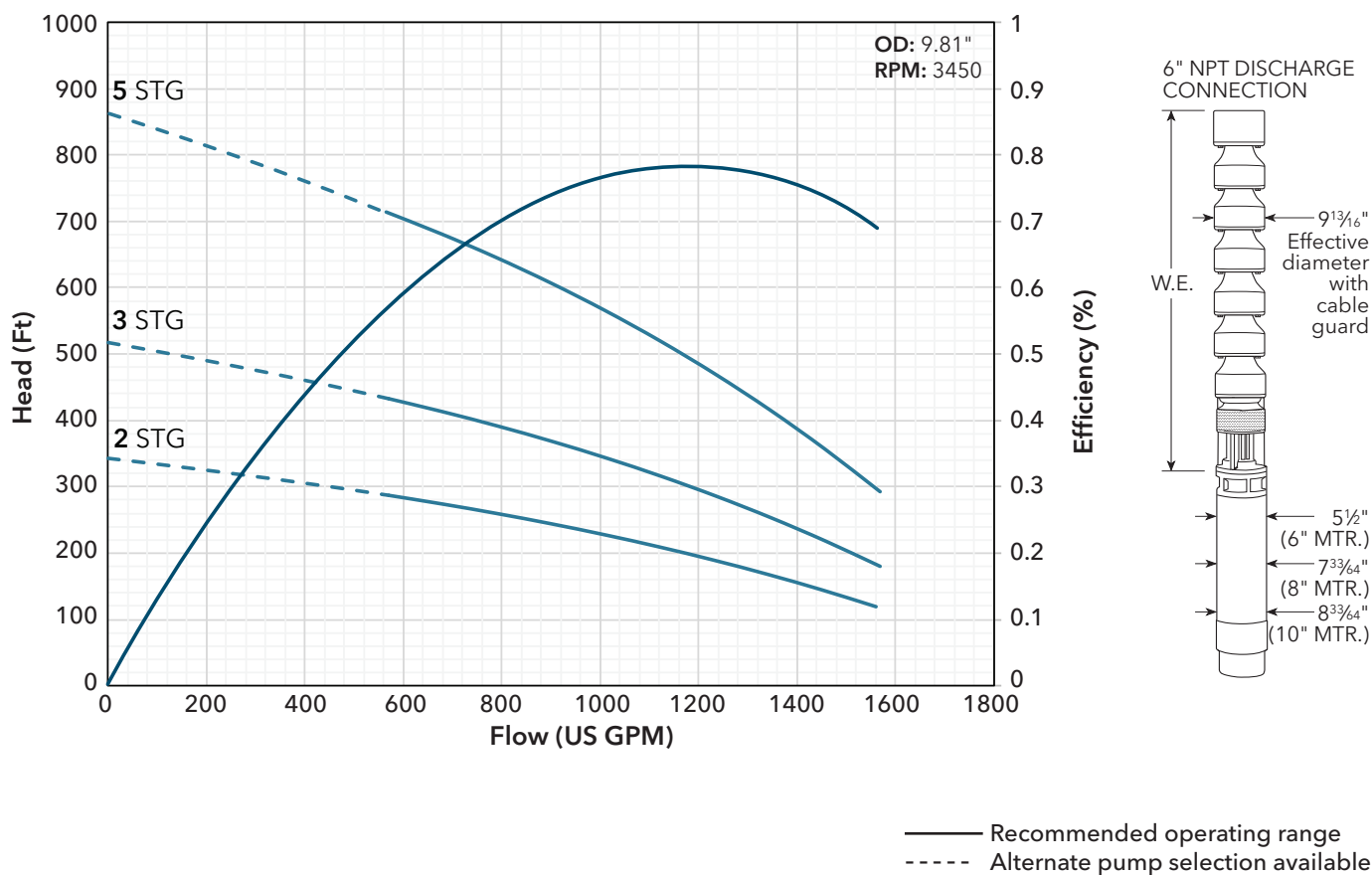

Stages	HP	W.E. Length (in)	W.E Wt. (lbs.)	W.E. Model Number	GWT Series Motor PN# (V)				
					200	230	460	575	230/460
2	75	34.8	270	G-09-TLC-02-075-8-6-B	N/A	N/A	8F754	8F755	N/A
3	125	43.5	334	G-09-TLC-03-125-8-6-B	N/A	N/A	8F1254	8F1255	N/A
5	200	70.1	492	G-09-TLC-05-200-0-6-B	N/A	N/A	N/A	N/A	N/A

**NOTES:**

1. Dimensions / Weights are not for construction purposes.
2. To use pre-configured model number, no changes are allowed with the exception of impeller trim.
3. Xylem pumps can be used with multiple motor brands. If no motor is listed, another manufacturer's is likely available, consult the submersible turbine pricebook (PTURBVS) for a complete list
4. Configuration shown is equipped with trimmed impellers as standard to remain below NOL hp.

## Turbine

**IMPELLER MODEL: 9THC**

**BEP FLOW: 1526 GPM**

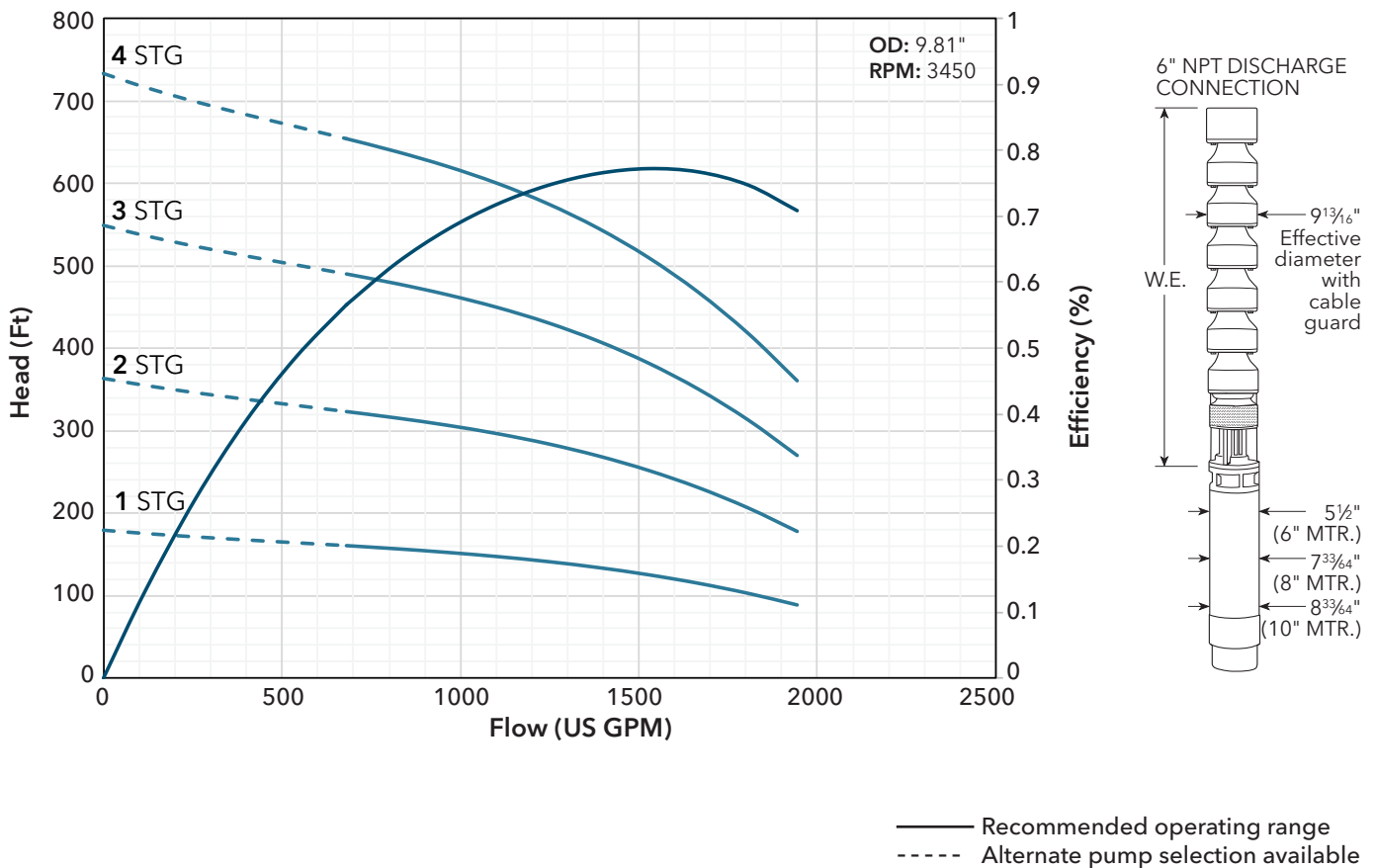

Stages	HP	W.E. Length (in)	W.E Wt. (lbs.)	W.E. Model Number	GWT Series Motor PN# (V)				
					200	230	460	575	230/460
1	75	28.9	200	G-09-THC-01-075-8-6-B	N/A	N/A	8F754	8F755	N/A
2	125	36.3	282	G-09-THC-02-125-8-6-B	N/A	N/A	8F1254	8F1255	N/A
2	150	36.3	282	G-09-THC-02-150-8-6-B	N/A	N/A	8F1504	8F1505	N/A
3	200	45.5	352	G-09-THC-03-200-0-6-B	N/A	N/A	N/A	N/A	N/A
4	250	57.8	422	G-09-THC-04-250-0-6-B	N/A	N/A	N/A	N/A	N/A
4	300	57.8	422	G-09-THC-04-300-0-6-B	N/A	N/A	N/A	N/A	N/A

**NOTES:**

1. Dimensions / Weights are not for construction purposes.
2. Models are selected to be non-overloading across the duty curve, except for highlighted selections which are non-overloading at the best efficiency duty point but may overload recommended motor size towards runout. Highlighted models stay below 1.15 service factor.
3. To use pre-configured model number, no changes are allowed with the exception of impeller trim.
4. Xylem pumps can be used with multiple motor brands. If no motor is listed, another manufacturer's is likely available, consult the submersible turbine pricebook (PTURBVS) for a complete list.

## Turbine

**IMPELLER MODEL:** 10WALC

**BEP FLOW:** 585 GPM

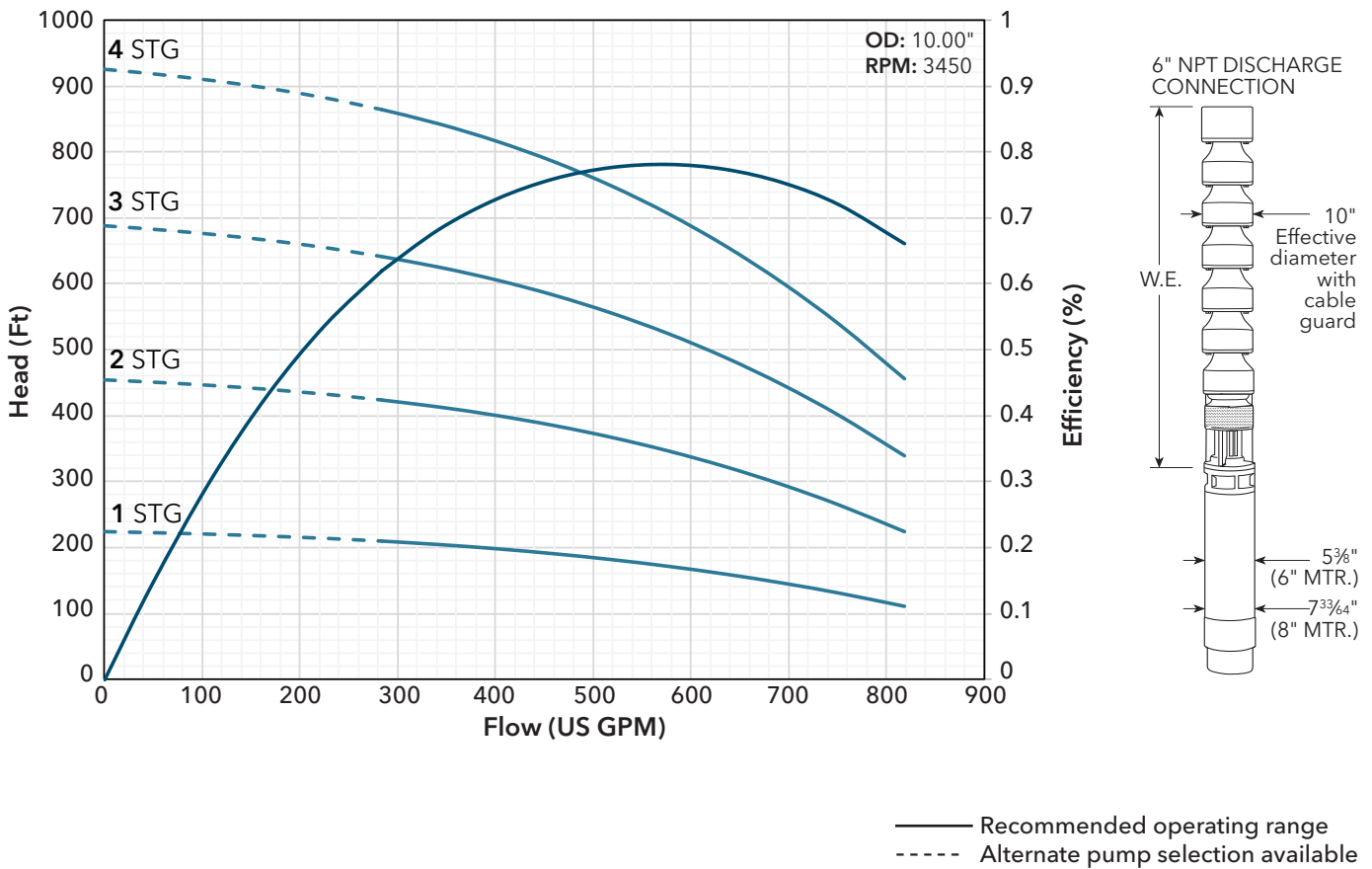

Stages	HP	W.E. Length (in)	W.E Wt. (lbs.)	W.E. Model Number	GWT Series Motor PN# (V)				
					200	230	460	575	230/460
1	40	27.3	183	G-10-WAL-01-040-6-6-B	N/A	N/A	6F404	6F405	N/A
2	75	33	244	G-10-WAL-02-75-8-6-B	N/A	N/A	#N/A	#N/A	N/A
3	100	40.6	300	G-10-WAL-03-100-8-6-B	N/A	N/A	8F1004	8F1005	N/A
3	125	40.6	300	G-10-WAL-03-125-8-6-B	N/A	N/A	8F1254	8F1255	N/A
4	150	48.3	356	G-10-WAL-04-150-8-6-B	N/A	N/A	8F1504	8F1505	N/A

**NOTES:**

1. Dimensions / Weights are not for construction purposes.
2. Models are selected to be non-overloading across the duty curve, except for highlighted selections which are non-overloading at the best efficiency duty point but may overload recommended motor size towards runout. Highlighted models stay below 1.15 service factor.
3. To use pre-configured model number, no changes are allowed with the exception of impeller trim.
4. Xylem pumps can be used with multiple motor brands. If no motor is listed, another manufacturer's is likely available, consult the submersible turbine pricebook (PTURBVS) for a complete list.

## Turbine

**IMPELLER MODEL:** 10WALC Trimmed

**BEP FLOW:** 577 GPM

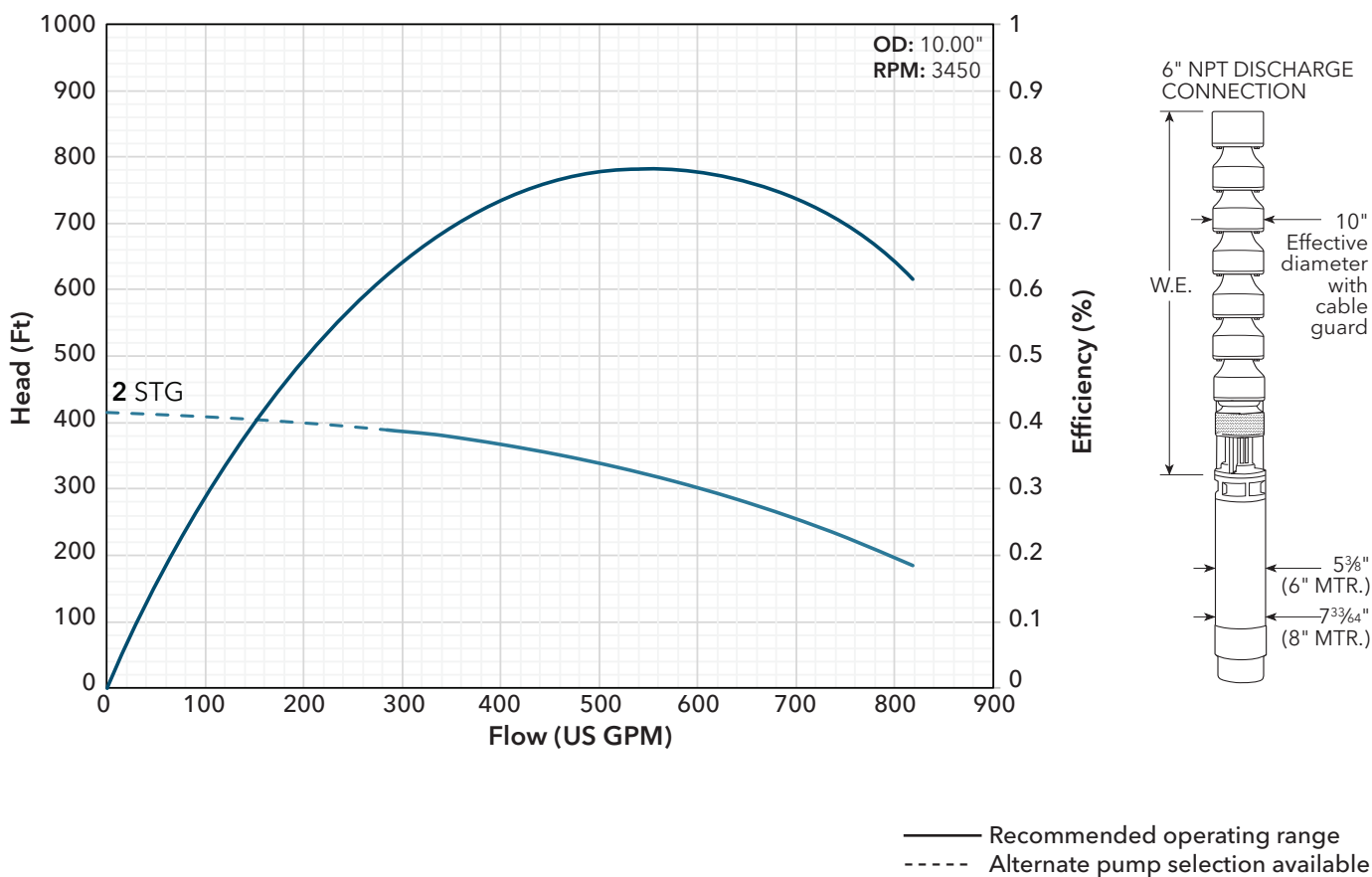

Stages	HP	W.E. Length (in)	W.E. Wt. (lbs.)	W.E. Model Number	GWT Series Motor PN# (V)				
					200	230	460	575	230/460
2	60	33	244	G-10-WAL-02-060-8-6-B	N/A	N/A	86F604	86F605	N/A

### NOTES:

1. Dimensions / Weights are not for construction purposes.
2. To use pre-configured model number, no changes are allowed with the exception of impeller trim.
3. Xylem pumps can be used with multiple motor brands. If no motor is listed, another manufacturer's is likely available, consult the submersible turbine pricebook (PTURBVS) for a complete list
4. Configuration shown is equipped with trimmed impellers as standard to remain below NOL hp.

**IMPELLER MODEL:** 10WAHC

**BEP FLOW:** 721 GPM

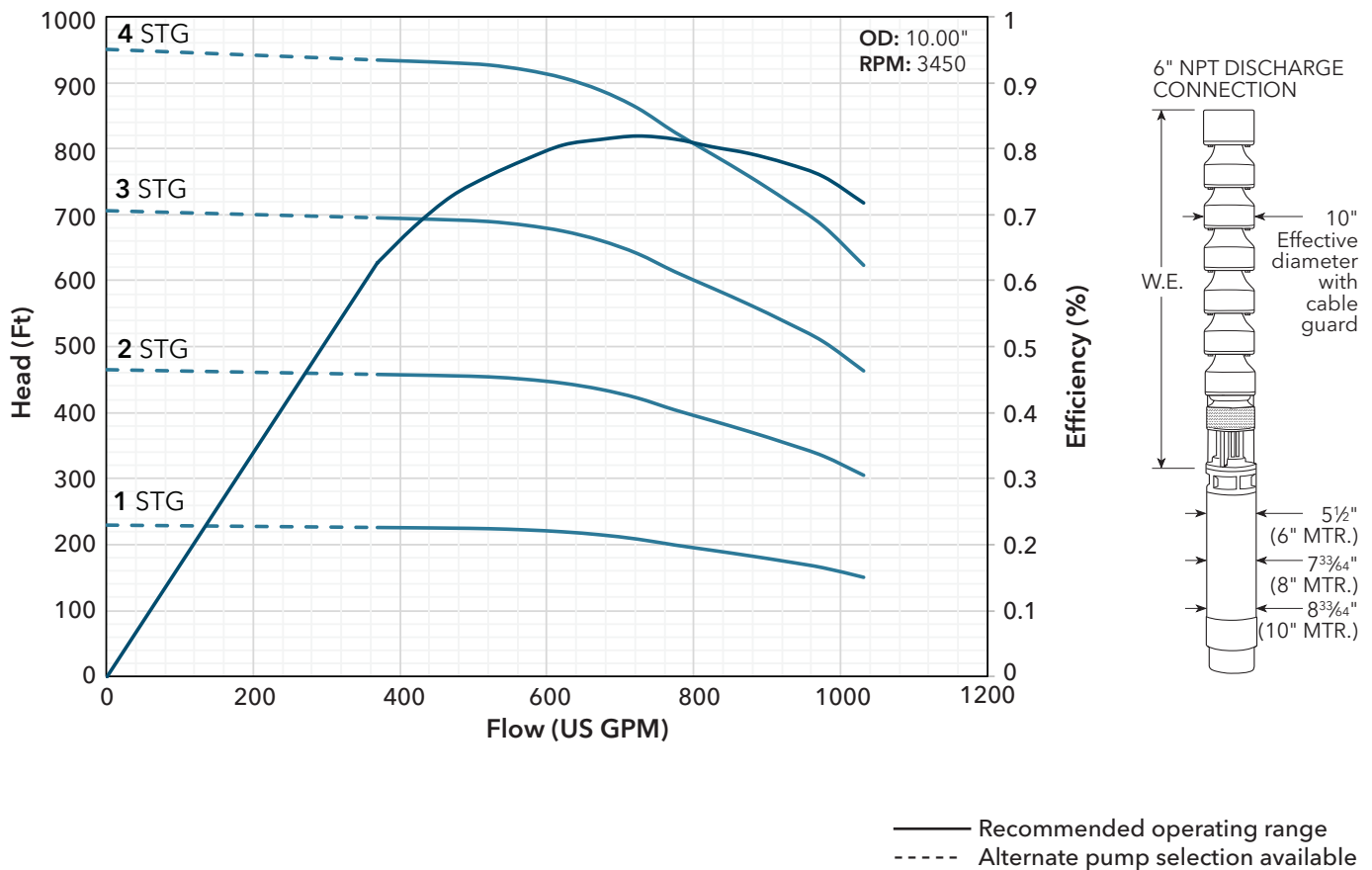

Stages	HP	W.E. Length (in)	W.E Wt. (lbs.)	W.E. Model Number	GWT Series Motor PN# (V)				
					200	230	460	575	230/460
1	50	27.3	183	G-10-WAH-01-050-6-6-B	N/A	N/A	6F504	6F505	N/A
1	60	27.3	183	G-10-WAH-01-060-6-6-B	N/A	N/A	86F604	86F605	N/A
2	100	33	244	G-10-WAH-02-100-8-6-B	N/A	N/A	8F1004	8F1005	N/A
2	125	33	244	G-10-WAH-02-125-8-6-B	N/A	N/A	8F1254	8F1255	N/A
3	150	40.6	300	G-10-WAH-03-150-8-6-B	N/A	N/A	8F1504	8F1505	N/A
3	175	40.6	300	G-10-WAH-03-175-8-6-B	N/A	N/A	N/A	N/A	N/A
4	200	48.3	356	G-10-WAH-04-200-0-6-B	N/A	N/A	N/A	N/A	N/A
4	250	48.3	356	G-10-WAH-04-250-0-6-B	N/A	N/A	N/A	N/A	N/A

**NOTES:**

1. Dimensions / Weights are not for construction purposes.
2. Models are selected to be non-overloading across the duty curve, except for highlighted selections which are non-overloading at the best efficiency duty point but may overload recommended motor size towards runout. Highlighted models stay below 1.15 service factor.
3. To use pre-configured model number, no changes are allowed with the exception of impeller trim.
4. Xylem pumps can be used with multiple motor brands. If no motor is listed, another manufacturer's is likely available, consult the submersible turbine pricebook (PTURBVS) for a complete list.

**IMPELLER MODEL:** 11CLC

**BEP FLOW:** 1228 GPM

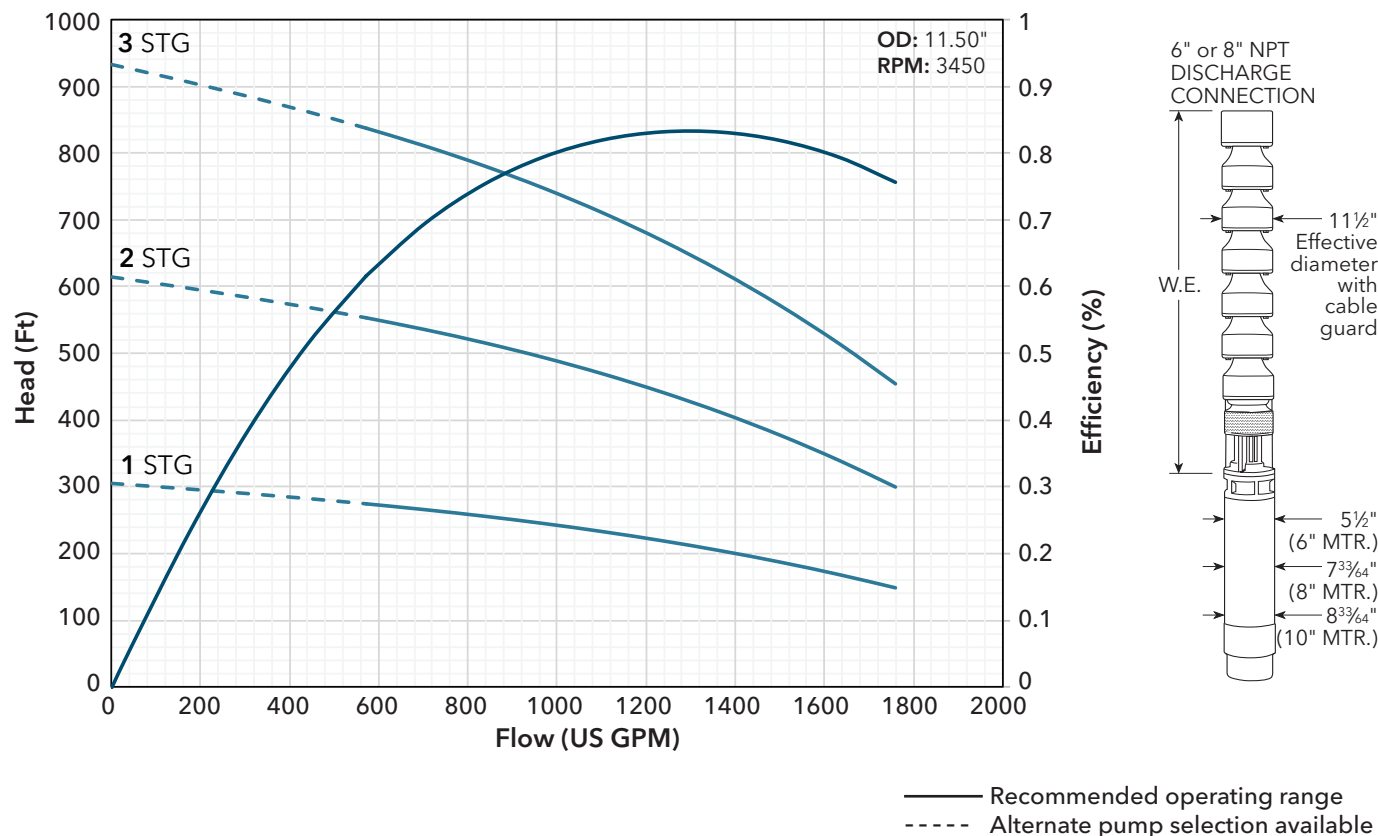

Stages	HP	W.E. Length (in)	W.E. Wt. (lbs.)	W.E. Model Number	GWT Series Motor PN# (V)				
					200	230	460	575	230/460
1	100	28.3	285	G-11-CLC-01-100-8-8-B	N/A	N/A	8F1004	8F1005	N/A
2	175	38.1	382	G-11-CLC-02-175-8-8-B	N/A	N/A	N/A	N/A	N/A
3	250	48	479	G-11-CLC-03-250-0-8-B	N/A	N/A	N/A	N/A	N/A
3	300	48	479	G-11-CLC-03-300-0-8-B	N/A	N/A	N/A	N/A	N/A

**NOTES:**

1. Dimensions / Weights are not for construction purposes.
2. Models are selected to be non-overloading across the duty curve, except for highlighted selections which are non-overloading at the best efficiency duty point but may overload recommended motor size towards runout. Highlighted models stay below 1.15 service factor.
3. To use pre-configured model number, no changes are allowed with the exception of impeller trim.
4. Xylem pumps can be used with multiple motor brands. If no motor is listed, another manufacturer's is likely available, consult the submersible turbine pricebook (PTURBVS) for a complete list.

**IMPELLER MODEL:** 11CLC Trimmed

**BEP FLOW:** 1148 GPM

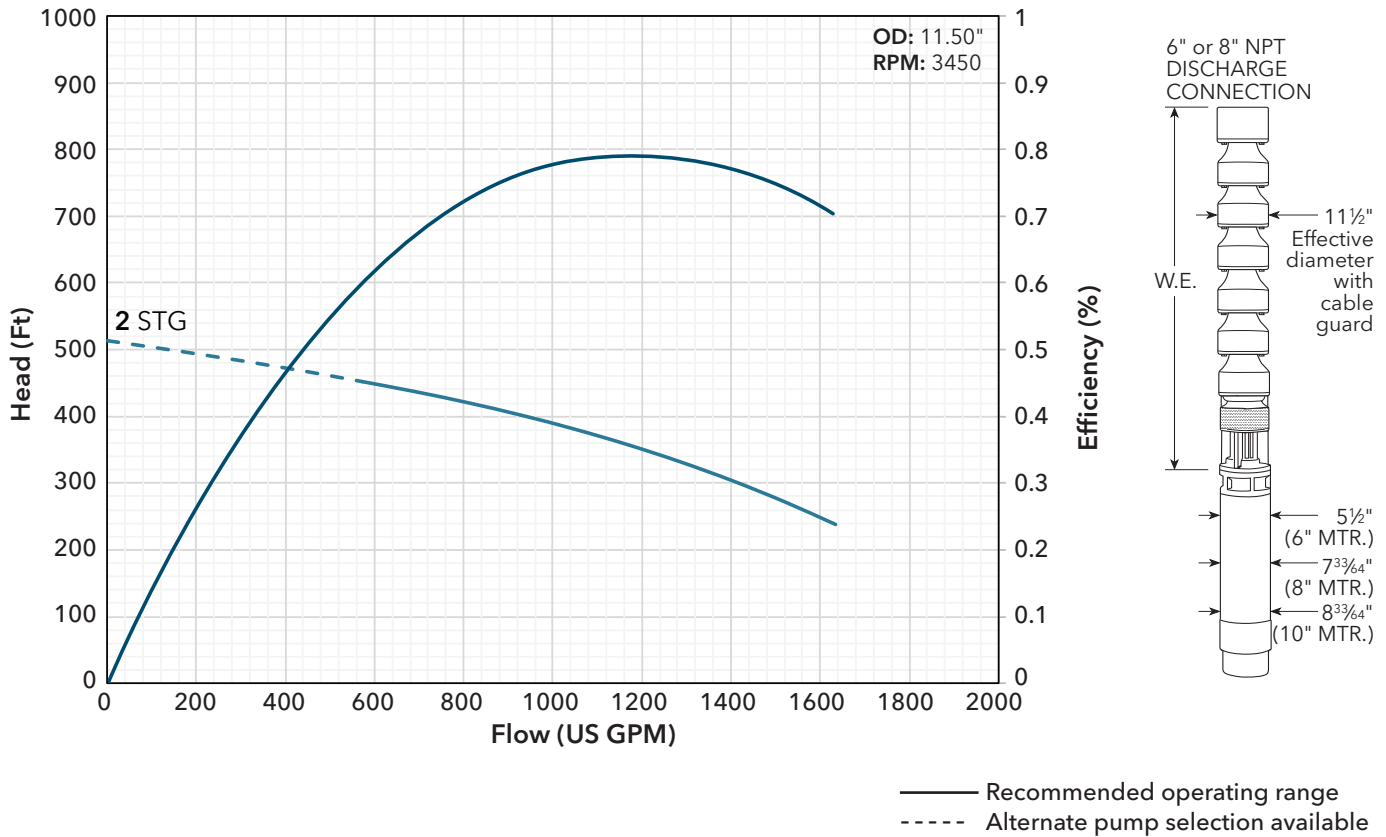

Stages	HP	W.E. Length (in)	W.E. Wt. (lbs.)	W.E. Model Number	GWT Series Motor PN# (V)				
					200	230	460	575	230/460
2	150	38.1	382	G-11-CLC-02-150-8-8-B	N/A	N/A	N/A	N/A	N/A

**NOTES:**

1. Dimensions / Weights are not for construction purposes.
2. To use pre-configured model number, no changes are allowed with the exception of impeller trim.
3. Xylem pumps can be used with multiple motor brands. If no motor is listed, another manufacturer's is likely available, consult the submersible turbine pricebook (PTURBVS) for a complete list
4. Configuration shown is equipped with trimmed impellers as standard to remain below NOL hp.



Xylem Inc.  
P.O. Box 5487, Lubbock, TX 79408  
Phone: (866) 673-0428  
Fax: (888) 322-5877  
www.xylem.com

Xylem is a registered trademark of Xylem Inc. or one of its subsidiaries.  
All other trademarks or registered trademarks are property of their respective owners.  
© 2024 Xylem Inc. BR5-11TPE R4 October 2024