

---

# Pre-Lubrication Recommendations

## 200.E.11

### **OPEN LINESHAFT PUMPS**

Open lineshaft pumps utilize neoprene lineshaft bearings which must be kept wet when the unit is operating. After the pumped liquid fills the column pipe, the bearings are kept lubricated by this liquid, however, at start up and shut down certain precautions must be taken to provide lubrication to these bearings.

**START UP:** Under normal conditions if the static water level is 30 feet or less pre-lubrication is not required since the bearings will hold enough moisture to provide initial lubrication. On deeper settings, however, it is necessary that the bearings receive pre-lubrication as outlined below.

**SHUTDOWN:** Non-Reverse Ratchet mechanisms mounted in the driver are recommended on units with settings of 50 feet or more. The Non-Reverse Ratchet prevents reverse rotation due to back flow, thus eliminating post-lubrication requirements. If Non-Reverse Ratchets are not employed post-lubrication must be provided using methods similar to those outlined below.

# Pre-Lubrication Recommendations

## 200.E.11

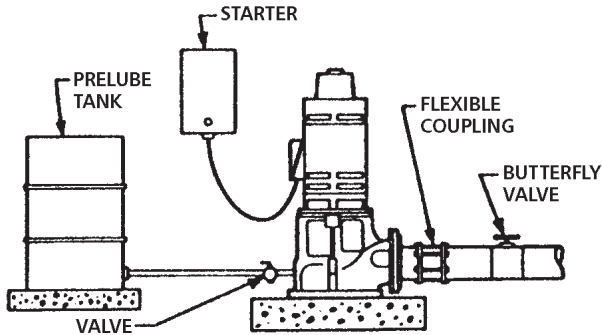

MANUAL CONTROL —  
OPEN DISCHARGE

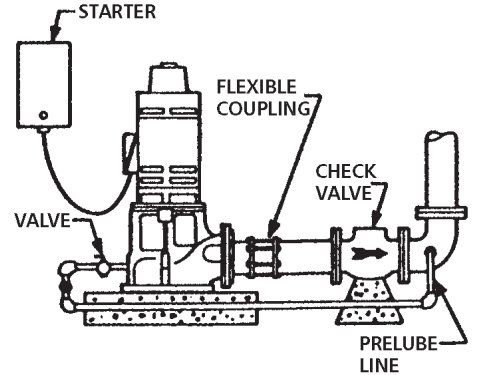

MANUAL CONTROL —  
PRESSURIZED DISCHARGE

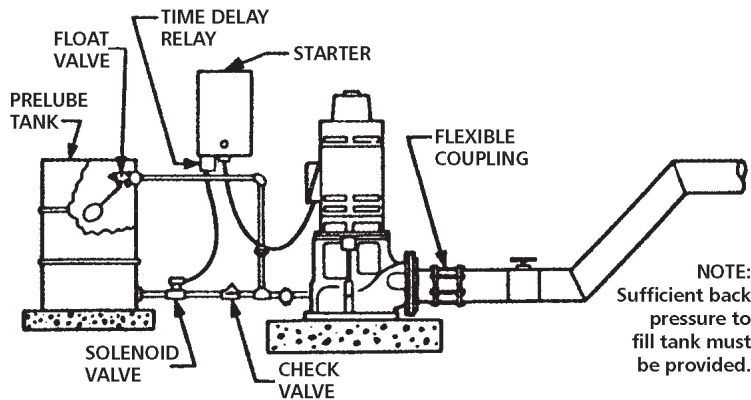

AUTOMATIC CONTROL —  
OPEN DISCHARGE

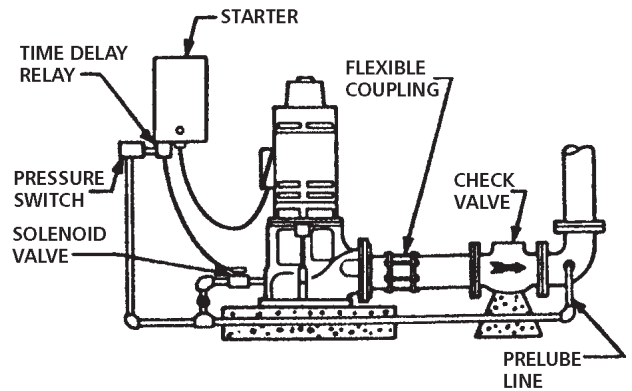

AUTOMATIC CONTROL —  
PRESSURIZED DISCHARGE

**Xylem Inc.**

[www.xylem.com/brands/gouldswatertechnology](http://www.xylem.com/brands/gouldswatertechnology)

Goulds is a registered trademark of Goulds Pumps, Inc. and is used under license.  
© 2012 Xylem Inc. D200E11 January 2009

**GOULDS**  
WATER TECHNOLOGY  
a xylem brand