

# hydrovar® X

INTEGRATED MOTOR & VARIABLE SPEED DRIVE SOLUTIONS  
**Ultra-Premium Efficiency, Connectivity and Simplicity**

Xylem's hydrovar® X line of products combine ultra-premium efficient motors with integrated variable speed drives and pumps. The result is intelligence, performance, connectivity, and simplicity in one comprehensive package, from one reliable source - Goulds Water Technology.

**Simple:** Built-in application software makes hydrovar X one of the easiest drives to commission, program and operate, enabling virtually any configuration of pumps.

**Sustainable:** No rare earth materials are used to minimize product availability challenges and address environmental concerns while offering smart technology and superior performance.

**Intelligent performance:** Advanced system controls (up to 8 pumps) are customizable for a wide range of applications. The IE5 "ultra-premium" hydrovar X smart motor provides one of the broadest efficiency ranges in the industry.

**Flexible:** hydrovar X solutions feature the right combination of motors, variable speed drives and pumps to ensure great performance and a rapid return on investment in nearly any application.

**Built-in protections:** Integrated functions provide protection for the pump and motor while optimizing performance.

**Easy service:** VFD and/or motor can be easily replaced individually, minimizing downtime and expensive repair.



*Separate quick connect components allow users to replace the drive or the motor independently. The integrated electrical socket requires no additional wiring, allowing a true plug and play solution versus buying a new motor and drive combination.*

5<sup>th</sup> generation Hydrovar®

new design hydrovar® X

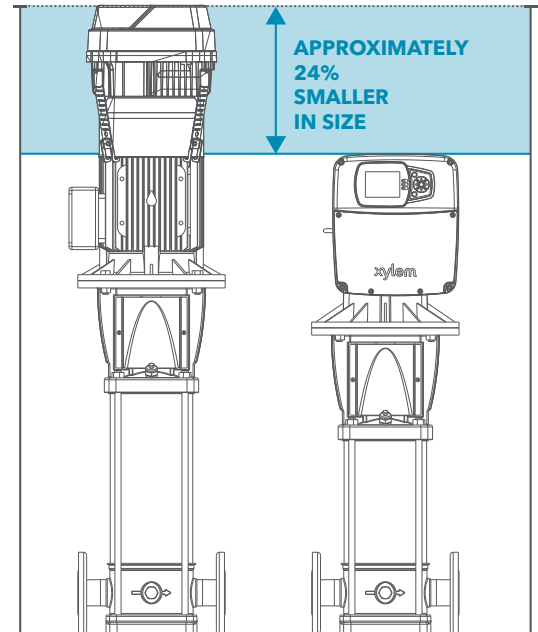

**Compact motor design:** hydrovar X motors offer higher performance with a reduced footprint when compared to the legacy generation Hydrovar solution. Increased performance reduces electricity consumption and lowers life cycle costs.

# Unleash the power of hydrovar X!

## Don't hold back your imagination!

With the graphical color display, you can quickly set-up and navigate the menu of your unit: check all the parameters and choose the perfect unit configuration to fit your installation. No time to do it? Genie will start up and run the unit for you!



## Check your systems from wherever

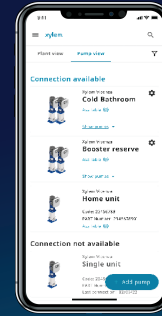

Download the mobile app



## hydrovar X and Avensor, better together!

hydrovar X can communicate with Avensor, Xylem's IoT platform, for a complete overview of all connected assets, anytime, anywhere. Avensor collects historical data to analyze trends and generate alerts preventing failures and equipment downtime.

## hydrovar X Smart Motor Specifications

<b>Display:</b>	Graphic Color
<b>Controls modes:</b>	Actuator, Constant Pressure. Proportional Pressure, Proportional Quadratic Pressure, Constant Flow, Constant Temperature, Constant Level
<b>Multi-Pump:</b>	up to 8 pumps
<b>Enclosure:</b>	IP55/NEMA4
<b>Working temperature:</b>	-4°/+122°F (-20°/+50°C)
<b>Communication Protocols:</b>	MODBUS® RTU, BACnet MS/TP
<b>Features:</b>	IE5 synchronous motor
<b>Mobile App:</b>	Bluetooth®

## Goulds Water Technology hydrovar X Product Family

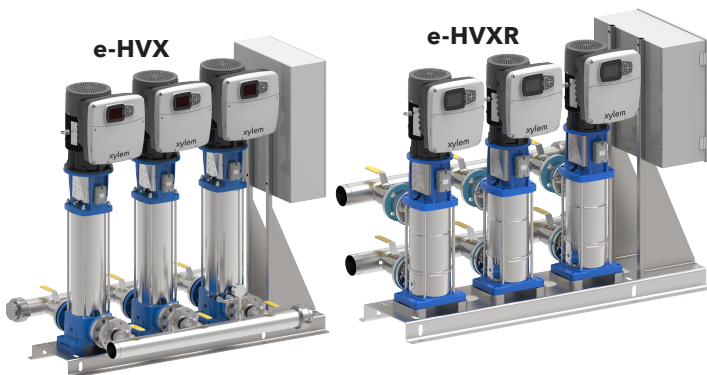

**Condition monitoring:** e-HVX and e-HVXR Packaged Booster Systems are fitted with Xylem's optimize® sensors to monitor the health of the pump and provide early warnings of potential issues that could lead to downtime and service costs.

## Performance

(representative example of increased performance with hydrovar X)

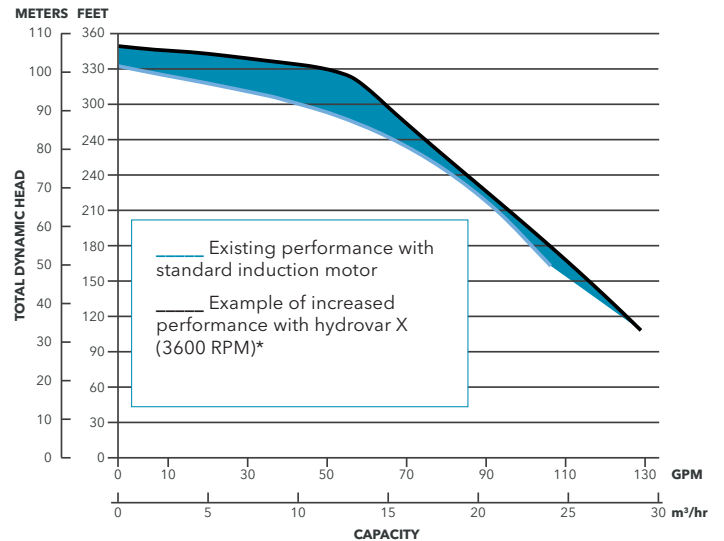

\*(4000 RPM) for e-SHX models



Learn more about the Goulds Water Technology hydrovar X product family

