

**TECHNICAL BROCHURE**

TEH-1208A

# Pump Selection for Building Service Systems



**Bell & Gossett**

a xylem brand

## TABLE OF CONTENTS

Introduction.....	1
Centrifugal Pumps.....	1
Major Components.....	1
Bernoulli's Principle.....	1
Centrifugal Impellers.....	2
Pump types.....	4
Single Suction Pumps.....	5
Internal Components.....	5
Mechanical Seal.....	5
Seal Limits.....	6
Close-Coupled Pumps.....	7
Multi-Stage Pumps.....	8
Vertical Turbine Pumps.....	8
Double Suction Pumps.....	9
Pump Installation Details.....	9
Suction Conditions.....	9
Suction Diffuser.....	10
Discharge Conditions.....	11
Triple Duty® Valves.....	11
Pump Foundation.....	11
Flexible Connectors.....	12
Pipe Supports.....	12
Pressure Gauges.....	12
Summary.....	12
Life Cycle Costs.....	13
Pump Selection.....	13
As a Decision-Making Process.....	13
For known flow and head conditions.....	14
Fixed Flow System.....	14
Variable Flow System.....	14
Variable Flow, Fixed Head System.....	14
System Curve.....	14
Moody Chart.....	15
Riding The Curve.....	16
Volute Choices.....	17
Base Mounted Versus In-Line.....	17
Flexibly Coupled Versus Close-Coupled.....	17
Single Suction Versus Double Suction.....	17
Selection Strategies.....	17
Best Efficiency Point and Preferred Selection Region.....	17
Maximum Impeller Diameter Limits.....	18
RPM Choices.....	19
Pump Selection-General Considerations.....	19
System Design.....	20
Summary.....	23

## Introduction

Buildings of all types and sizes use pumps for fire protection, heating, cooling and for domestic water distribution. While these pumps do not generally represent a large fraction of the total building cost or energy budget, careful selection of the pump type and size will reduce both the first cost of the building, and the cost of operating the building over the years. More importantly, proper selection of the pumps will make the building more valuable by providing reliable, sustainable service at low cost. This manual will discuss the operation, selection, and installation of centrifugal pumps, the most widely used type of pump in building service.

## Centrifugal Pumps

### Major Components

A centrifugal pump consists of three major components:

- The volute, pump casing or pump body is the most obvious component. It contains the pumped fluid under pressure.
- The impeller is the rotating element inside the volute. It applies work to the system fluid.
- The driver is the source of power for the impeller. In building service applications, it's typically an electric motor.

### Bernoulli's Principle

Daniel Bernoulli, (1700-1782) was a Dutch-Swiss mathematician and natural philosopher who wrote "Hydrodynamica" in 1738. He applied the principle of conservation of energy to the special problem of liquid flow. "Energy" is the ability to do work. Work in this sense is done whenever a force is exerted through a distance, so work and energy are often measured in units of "foot-pounds". "Conservation" simply means that energy cannot be created nor can it be destroyed—but it can be converted among various forms. Bernoulli taught that a liquid can do work by virtue of its pressure, elevation, or velocity. The sum of these three is called the "total fluid head". Applying the idea of energy conservation means that a liquid at some initial point, "a", already has a total fluid head. At some different point, "b", there may be differences in pressure, elevation and velocity, but the total fluid head will be conserved. Mathematically, we can think of it as follows:

$$\frac{P_a}{w} + Z_a + \frac{V_a^2}{2g} = \frac{P_b}{w} + Z_b + \frac{V_b^2}{2g} \quad (1)$$

Where:

P is the pressure imposed by the liquid at point "a" or "b" in units of pounds per square foot.

W is the density of the liquid in pounds per cubic foot. The first term is often called the fluid "pressure head"; the ability of the fluid to do work by virtue of its pressure.

Z is the elevation of the point above some arbitrary reference, in feet. The reference has to be the same for both points. This term may be called the "elevation head"; the ability of the fluid to do work by virtue of its elevation.

V is the velocity of the liquid at the point in feet per second.

g is the gravitational constant in feet per second per second. This term is the "velocity head"; the ability of the fluid to do work because of its velocity.

Given these units, each term will have units of "feet of head" which is a shorthand way of saying that each pound of the liquid can apply so many foot-pounds of work, or that so many foot-pounds of work have been applied to the liquid.

Several important assumptions lie behind the derivation of equation (1).

- The liquid is incompressible. That is, the volume of the liquid doesn't change if it's exposed to a higher pressure, in other words, liquid density is constant. In reality, liquids are not very compressible. For water, an increase of 1 atmosphere (about 14.7 lb/in<sup>2</sup>) will decrease volume by about 0.000053%.
- The liquid is flowing in "streamlines". That means the path followed by a tiny volume of liquid doesn't cross the path of any other volume, so both points "a" and "b" must be on the same streamline. In real systems, this "laminar flow" is rarely encountered. In fact, "turbulent flow", where streamlines cross, is often desirable.
- There's no "friction". Friction is the force which resists the relative motion between the liquid and the pipe wall. It's useful to think of it as a process which converts kinetic energy to thermal energy. In real systems, there's always at least a little friction.
- No work has been applied to the liquid, or done by the liquid, as it moves from "a" to "b" so the total fluid head is a constant. It is very common to apply work to the liquid in order to increase the total fluid head...that's the usual role of the pump in the system. It is also possible to extract work from the liquid flow by running water from a higher elevation or higher pressure through a pump to some point at lower elevation or pressure. The pump shaft could be connected to an electrical generator; the pump would be acting as a turbine. This kind of application is not impossible, but it's also not common. Even though real systems don't match the theory exactly, the differences are small enough to ignore without introducing too much error. Bernoulli's principle provides a convenient framework for understanding centrifugal pumps and the systems they serve, but to make it even more useful, we'll have to understand more about fluid friction and exactly how a pump applies work to increase total fluid head.

## Centrifugal Impellers

A centrifugal impeller increases total fluid head by applying work to the liquid. We can think of work as the amount of energy transferred by a force, or application of a force through a distance. If the force is measured in pounds, and the distance in feet, then units for work would be ft-lbs. Suppose we punch some holes near the bottom of a coffee can, and then fill it with water. We would observe the water flowing out of the holes, initially at high velocity, then at lower velocity as the level in the can decreases. Applying Bernoulli's Principle, let's say point "a" is at the top of the liquid, at atmospheric pressure and low velocity. Point "b" is also at atmospheric pressure, but at a lower elevation at the bottom of the can, and higher velocity. If total head is a constant, we can think of the initial high elevation being "converted" to high velocity. As the can empties, the lower elevation head converts to lower velocity. This idea of the "convertibility" among the three components of total fluid is crucial to understanding how a pump increases total fluid head.

Now, let's use a pipe to supply water to the can, keeping the level, and the elevation head, constant, and rotate the can around its vertical axis. We would observe that the velocity of the water leaving the holes is higher than it was when the can was at rest at the same water level. The increase in velocity represents the work being applied by the can to the water. As the can rotates, water accelerates away from the center of rotation toward the holes, leaving at a higher velocity. "Centrifugal" means "moving away from the axis", so we can think of "centrifugal acceleration" acting along the radius of the can on the mass of water. According to Newton's second law, a force is required to accelerate a mass, so we now have all the elements required to apply work...force acting through a distance.

A real pump impeller is equipped with curved vanes to accelerate the water more efficiently.

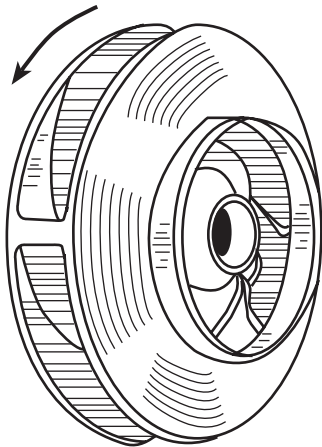

**Typical Centrifugal Impeller**  
Figure 1

Notice the direction of rotation. If the impeller rotates backward, the vanes "dig into" the water, accelerating it very inefficiently. That leads to an important installation tip: always check for correct rotation by examining the volute shape, or look for an arrow cast into the volute. This is especially important in larger pumps that use three-phase motors since the direction of rotation can be reversed by changing any

two motor lead wires. Smaller pumps often use single-phase motors which have some kind of starting mechanism to get them rotating in the correct direction.

## Impeller Types

Many impeller designs are used in building service pumps. One of the simplest is the "open impeller"

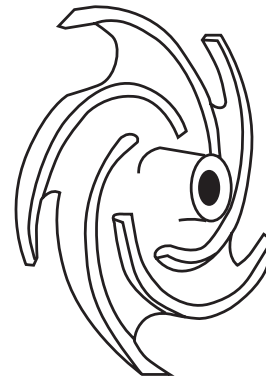

**Open Impeller**  
Figure 2

Open impellers are essentially nothing but a hub and curved vanes. They are often very small, non-metallic, and inexpensive, for use in small pumps. They are not very efficient since water can freely circulate parallel to the hub axis as well as at right angles to the axis...the desired direction. In small pumps, the manufacturer will install the impeller close to the fixed parts of the pump body to try to direct the water in the right direction. That means there's a lot of friction, and therefore, lower efficiency. The traditional attitude toward pumps like this has been that small pumps like these don't use a great deal of electrical energy, so low efficiency is not necessarily an important issue. On the other hand, large numbers of less-efficient pumps in a building will waste a great deal of energy.

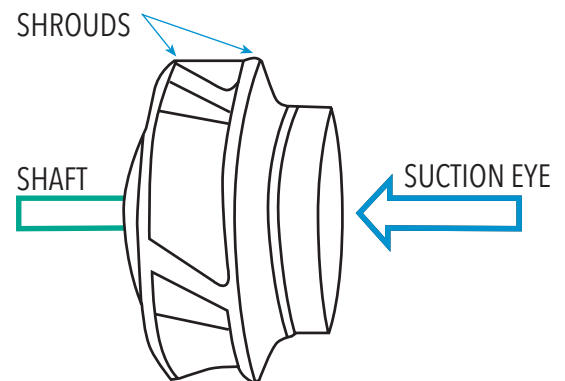

**Closed Impeller**  
Figure 3

The impeller in Figure 3 has discs, or "shrouds" that direct the liquid to flow more efficiently at right angles to the axis, or "radially" across the shroud. It's called a "closed impeller", and because of its better efficiency, it's much more widely used, especially in larger pumps that can handle larger flow rates, and therefore require greater energy input. The impeller in Figure 3 is also called a "single suction impeller" since all the liquid enters the "suction eye" on the same side of the impeller. This will exert large axial forces on the bearings that support the shaft.

A "double suction" impeller is often used to minimize axial forces on the pump shaft.

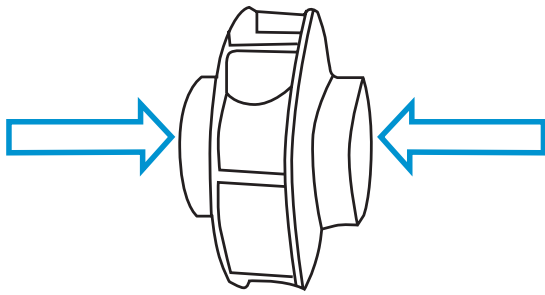

**Double Suction Closed Impeller  
Figure 4**

If the liquid enters both sides of the impeller equally, the axial forces cancel, meaning that the shaft bearings don't need to oppose any significant axial loading. There are several other good reasons for using double suction impellers to handle higher flow rates. We'll discuss them later.

Some building pumps like sewage ejectors and sump pumps must handle large solids that would clog a closed impeller. These pumps would use a "non-clogging" impeller like the one in Figure 5.

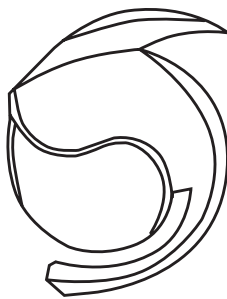

**Non-Clogging Impeller  
Figure 5**

Notice that it has no shrouds and only a few vanes. Some impellers in sewage pumps can actually grind the solids to smaller pieces that can flow through the pump and piping. "Clean water" applications don't need these special impellers; they can use more efficient closed impellers. Hot or cold tap water certainly qualifies as "clean water". In fact, there are special requirements for potable water equipment to insure that germs and bacteria won't be spread through the water supply. Systems that use water to heat and cool the building are also classified as clean water systems. Even though the liquid in those systems may contain small solid particles or other things that would make it unfit for consumption, the pump can still use a closed impeller.

Occasionally, axial flow impellers can be found in building pumps.

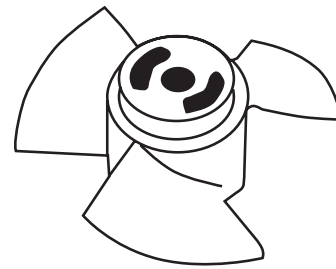

**Axial Flow Impeller  
Figure 6**

Impellers like this apply work by the lifting action of the vanes, much like a ship's screw, so the liquid enters and leaves the impeller parallel to the shaft. For comparable sizes, axial flow impellers can't apply as much work as the other impellers we've discussed, but there are applications where they can be useful.

### Impeller Design

Impellers are not strictly radial or axial flow. Designers can vary impeller features to provide a very wide range of performance. A number called the "specific speed" is used to describe where a given impeller fits on the continuum between radial flow and axial flow. The Hydraulic Institute, (HI), is the organization which sets the standards for manufacturing, testing, and naming pumps of all kinds. According to the HI, specific speed is

"...the revolutions per minute at which a geometrically similar impeller would run if it were of such a size as to discharge one gallon per minute against one foot of head."

Hydraulic Institute Standard 1.1 - 1.2 2000  
Section 1.1.4.1

Perhaps Figure 7 is a more useful way of thinking about specific speed.

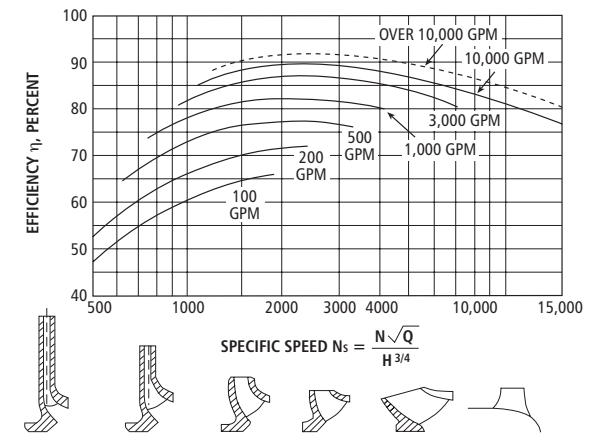

**Impeller Profile, Specific Speed, and Efficiency  
Figure 7**

Low specific speed impellers have radial flow profiles. The maximum efficiency they can achieve is low, and it's achieved at low flow rates.



Higher specific speed impellers start to mix radial and axial flow characteristics, providing better theoretical efficiency at higher flows.

Very high specific speed impellers can move very large volumes of liquid, though their theoretical efficiency declines a bit.

This is the kind of analysis that an impeller designer applies at the beginning of the pump design process. As pump users, we don't plan to get into impeller design—we're just looking for the best existing impeller to solve a specific problem.

A typical clean water system pump will most often use a medium specific speed closed impeller in order to maximize the theoretical efficiency for a given flow requirement. For low flow rates, a single suction impeller may serve, but at higher flow rates, we may prefer a double suction impeller.

### Impeller Trim

It is often useful to tailor the impeller performance to match the system requirements. The term "impeller trim" means reducing a full diameter impeller by cutting away some of the shrouds and vanes on a lathe. The reduced diameter impeller rotating at full rpm will apply less work to the fluid, making it more suitable for a system that doesn't require the total fluid head provided by the full diameter impeller.

### Volute Types

An impeller increases the velocity component of the total fluid head; the volute directs the liquid and converts the velocity head component to pressure head. "Volute" comes from the Latin word for "scroll"; a snail's shell has the shape of a volute.

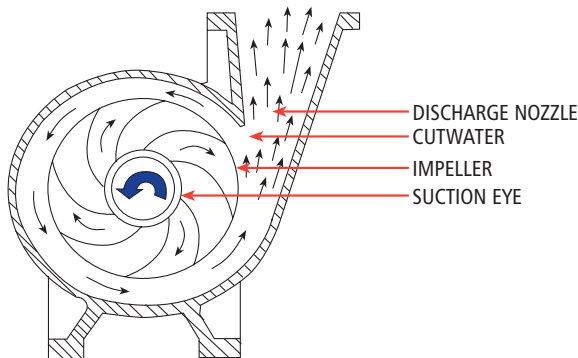

**Impeller and Volute Interaction**  
Figure 8

In Figure 8, the circular impeller accelerates the liquid from the suction eye toward the rim. The bold arrow represents impeller rotation, the smaller arrows the direction of liquid flow. The volute shape results in a narrow gap between the impeller and volute at the "cutwater", or "throat", increasing in area in the direction of flow. This gap of constantly increasing cross sectional area captures the high velocity liquid leaving the tips of the impeller vanes, and directs it to the discharge nozzle at approximately constant velocity. At the cutwater, there's only one vane's discharge, but the flow rate increases in the direction of rotation as each vane discharges more

liquid into the gap. In order to keep the velocity constant, the area available for flow must increase. Flow entering the discharge nozzle is constant, the sum of all the vane flows. The increasing cross sectional area in the "diverging" nozzle results in a decrease in overall liquid velocity, converting the velocity head to pressure head. The overall effect of the pump is to apply work to a pound of liquid at lower suction pressure, then discharge it as a pound of higher pressure liquid at the discharge.

How well does real pump performance match this theoretical description?

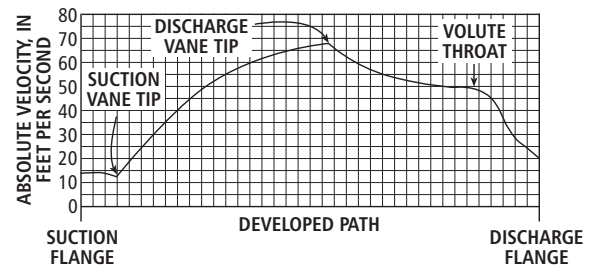

**Flow Velocity in the Pump**  
Figure 9

Figure 9 shows that the liquid velocity rises quickly as it's accelerated along the impeller vane, then slows a little bit in the volute, finally slows a lot in the discharge nozzle. This may represent the best practical result achievable by the pump designer for a given pump at a given flow rate. As we'll see, in real systems the flow may change, the impeller may be trimmed, or may not operate at the design rpm. Over time, the pump may corrode or suffer other damage; so it's likely that actual performance will differ from the theoretical prediction.

### Pump Types

Pump manufacturers have developed many volute and impeller combinations in order to meet the requirements imposed by different systems. "Pump selection" is the process of matching, as well as we can, the characteristics of the pump to the requirements of the system. In order to do that, we must know what kinds of pumps are typically available for use in building service systems.

### Single Suction Pumps

One of the most common types is the end-suction, base mounted, flexibly coupled pump shown in Figure 10.

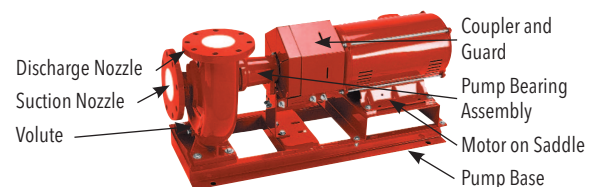

**Bell & Gossett Series 1510**  
Figure 10

The volute suction nozzle is located at the end of the pump, in line with the horizontal pump shaft. A "coupler" connects the motor shaft to the pump shaft, allowing some degree of flexibility to compensate for misalignment between the two shafts. All the components; volute, pump bearing assembly, and motor are mounted on a sturdy base. In pumps like this, the suction nozzle is larger than the discharge nozzle. The nozzle size can be used to describe the size of the volute, since this type pump is available in over twenty sizes. For example; a pump with a 3" suction nozzle could have a 2 1/2" or even a 2" discharge nozzle, so the volute could be described as a 2 1/2 x 3 or 2 x 3, the discharge nozzle is always stated first. Each volute casting determines a maximum impeller diameter which can be designated by a letter. For example; the letter "B" might designate a 9 1/2" maximum impeller size, so a 4B volute would have 4" discharge, 5" suction nozzles, and be able to accommodate a 9 1/2" diameter impeller.

End suction pumps can handle flows ranging between 40 - 4000 gpm, at heads ranging between 40 - 500 feet TDH, where "TDH" stands for the "Total Dynamic Head". Remember that the pump applies work to each pound of liquid, so it's appropriate to designate a pump's capacity in terms of foot-pounds of work per pound of liquid, or feet of head. In these pumps, the discharge velocity must be greater than the suction velocity because of the difference in nozzle sizes, so the effect of the pump is to increase the velocity as well as the pressure of the liquid. The term TDH recognizes that both of these components of total head are being changed.

## Internal Components

Figure 11 shows the impeller and other internal components.

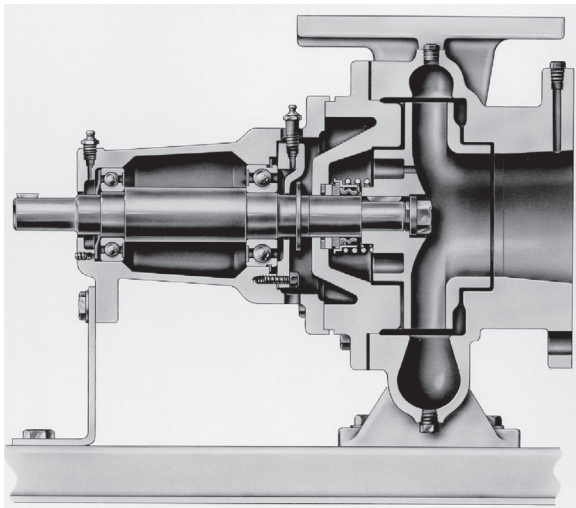

**End Suction Pump Section View**  
**Figure 11**

The single suction impeller is bolted to the end of the pump shaft, which extends through the volute cover plate. There must be enough clearance between the shaft and the cover plate to avoid metal to metal contact, but the resulting gap could also allow liquid to leak out of the pump. The mechanical seal acts to prevent this leakage.

## Mechanical Seal

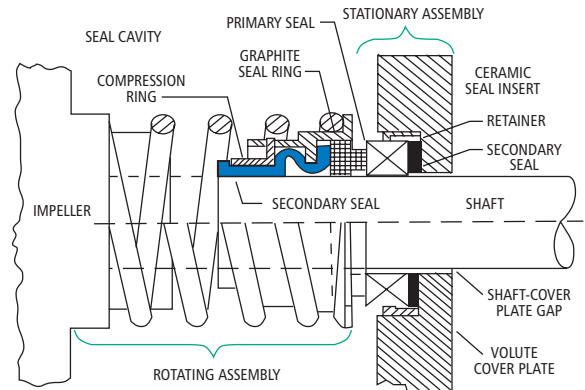

**Typical Mechanical Pump Seal**  
**Figure 12**

The inside of the pump's volute cover plate is counter bored to form a recessed area around the shaft inside the pump. A ring-shaped "seal insert" is placed in the counter bore along with some type of retainer to prevent it from spinning. Ceramic is a common material for the seal insert because it's hard, durable, and can be given an extremely flat, highly polished face. Another ring, the "seal ring" is affixed around the shaft. Both of these rings inside diameters are large enough so that they will not touch the rotating shaft. The seal ring is often made of carbon, and also has a highly polished face that is pressed against the polished face of the seal insert by a seal spring. The spring is centered on the shaft and seated against the impeller. The contact area of these polished faces forms the "dynamic seal", or "primary seal" allowing the shaft and seal ring to rotate without visible leakage around the shaft. Of course there's going to be some friction and heat as the two rings rub against one another, so the water inside the seal cavity plays an important role in "flushing" the seal. The action of the impeller raises water pressure inside the seal cavity compared to the atmospheric pressure outside the pump. This difference in pressure forces a thin film of water across the seal faces, lubricating them to reduce friction, and absorbing the frictional heat that is formed. In the process of absorbing that heat, the water evaporates, and leaves the pump as a tiny amount of invisible water vapor. This cooling and lubricating action is important in any pump, and that's why a pump should never be run without water in it. Lacking flush water, the seal rings will over-heat and fail, causing the pump to leak badly around the shaft. In addition to the primary seal, most designs have "secondary seals" too. These are "static" seals, meaning that the components are not moving with respect to each other. For example, water could leak out of the pump in back of the seal insert, so the secondary seal in that area is a synthetic rubber gasket that prevents leaking, and helps to hold the insert stationary so it won't spin in the counter bore. Another secondary seal is applied at the shaft. Water could flow along the surface of the shaft, bypassing the primary seal and leaking out of the pump. Another synthetic rubber, or "elastomer", is used here to prevent that leakage. It's clamped tightly to the shaft by a metal "compression ring". This secondary seal really does two things: it prevents leakage and causes the seal ring to rotate with the shaft.

## Seal Limits

In most building service pumps the system water flushes the seal. Therefore, the manufacturer chooses seal materials that will be compatible with:

- **System Temperature.** The synthetic elastomer seal components determine the seal's temperature rating. Long exposure to temperatures greater than the seal temperature rating will cause these secondary seals to harden, crack, and leak. Fortunately, building heating systems are usually designed for the "Low Temperature Range" as defined by ASHRAE with supply temperatures lower than 250°F. Several varieties of ethylene propylene elastomer operate quite well below this limit. Buna N, or nitrile is another widely used elastomer, but its temperature limit is 225 °F.
- **System PH.** The flush water pH is a measure of acidity or alkalinity. Neutral water has a pH of 7, acidic conditions exist at pH less than 7, alkaline conditions above 7. Acidity over a long period will cause failure of the piping system as metal corrodes and pipe walls become thinner. For steel pipes, corrosion can be minimized by a slightly elevated pH—8.0 to 8.5. Treatment chemicals dissolved in the water can establish the desired pH.
- **Concentration of Dissolved Solids.** Treatment chemicals are examples of dissolved solids—they cannot be separated from the water by strainers or filters. Concentrations of dissolved solids above 1000 parts per million, ppm, resulting from over treatment can reduce seal life. The thin film of water which cools and lubricates the seal faces evaporates due to frictional heat leaving the abrasive solids behind. These solids can cause rapid failure of the primary seal faces. Typical water treatment chemicals don't require concentrations as high as 1000 ppm, so primary seal materials like ceramic and carbon are perfectly acceptable.
- **Suspended Solids.** Suspended solids can be separated from the water by filters or strainers. Examples would include tiny rust or dirt particles, or construction debris left in the piping. Centrifugal pumps can handle fairly large solids without damage although a pebble passing through the impeller certainly isn't doing it any good. Seals can be damaged by small solids being carried into the primary seal. Rust and sand are especially abrasive, so careful cleaning and flushing of the system should always be carried out prior to commissioning the system. All too often, this flushing is not done effectively, so seals fail sooner than expected.

## Stuffing Box.

Older pumps were built with a "stuffing box" around the shaft where it penetrated through the volute cover plate. These stuffing boxes were fitted with multiple rings of flexible compression packing to limit the amount of leakage around the pump shaft.

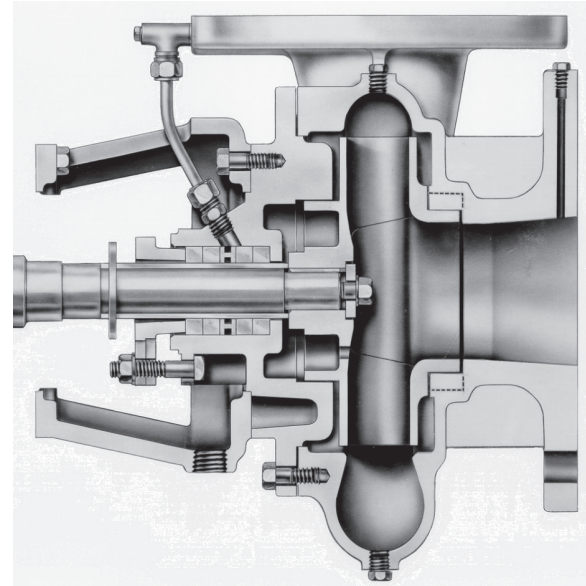

**Series 1510 Stuffing Box Type  
Figure 13**

Since the packing rings were in contact with the rotating shaft, they had to have a steady flow of water leaking out of the pump to carry away the frictional heat so it wouldn't cause the rings to become hard and damage the shaft. That "leak-off" was usually 50-80 drops per minute. One of the routine jobs associated with these pumps was to adjust the packing glands to limit the amount of water leaking out of the pump. Frequently, someone had to "repack" the pump stuffing boxes, replacing the worn compression packing with new rings. Pumps are still made with stuffing boxes and compression packing although they are not as common as they used to be, especially in HVAC systems. The reason for this is that most heating and cooling systems are built as closed pressurized systems. If the pump stuffing box has to have 50 to 80 drops per minute of leakage in order to cool the packing rings, then the system pressure can be maintained only by continuously adding water to make up for the loss. This new "make-up" water can carry dissolved gas and minerals that will increase corrosion and scaling in the system. In a sense, it's not a closed system anymore if water is constantly being added. Since a properly installed mechanical seal does not need any leak-off, pumps with mechanical seals are the best choice for many building service pumps, and especially for closed heating and cooling systems. Fire pumps are always equipped with stuffing boxes and packing glands in order to meet the strict requirements established for this important life-safety equipment.



### Close-coupled pumps

The pump in Figure 14 has many of the same components as the Series 1510, but it lacks a pump shaft and pump bearing assembly. The single suction impeller is installed directly on the motor shaft, it has no coupler, so it's called a "close coupled" pump.



**Close Coupled End Suction, Series 1531 Pump  
Figure 14**

This pump takes up less floor space in an equipment room, a significant advantage since space is often limited. On the other hand, the motor must be specially made to adapt to the volute, the shaft must extend into the volute, and the motor bearings must be able to handle not only the forces imposed by the motor rotating element, but also the forces imposed on the impeller. Motors like this are limited in size, thus limiting the size of these pumps.

### Large In-Line Pumps

The single suction impeller can also be used with in-line mounted volutes like the ones in Figure 15.

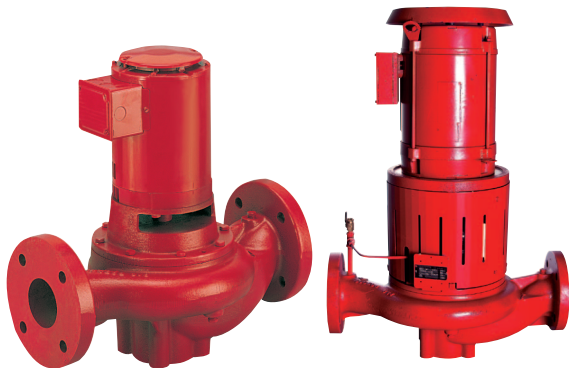

**Large In-Line, Series 80 Pumps  
Figure 15**

These are often equipped with mechanical seals, but the volutes are significantly different. They are mounted in the piping, so the suction and discharge nozzles, and the nozzle velocities, are the same. The pump on the left is close coupled; the one on the right has separate motor and pump shafts connected by a rigid coupling. This allows the use of standard motors, and therefore, larger pumps.

### Small In-Line Pumps

These pumps use in-line volutes and single suction impellers, but they are mounted with the shaft in a horizontal orientation.

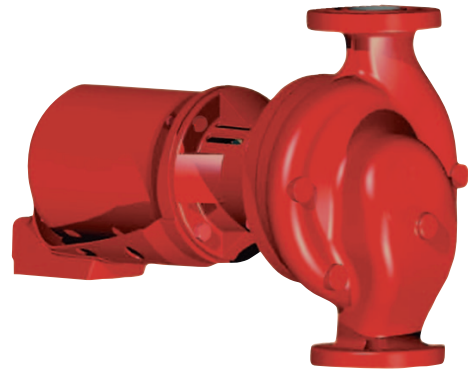

**Small In-Line, Series 60 Pumps  
Figure 16**

The flexible coupler and pump bearing assembly allow the use of standard motors. There are several sizes of Series 60 pumps capable of handling up to 200 gpm at 55 feet of head.

### Circulator



**Series PL and Series 100 Circulators  
Figure 17**

The Series PL is close coupled and the Series 100 is flexibly coupled, although these terms are rarely used in small pumps. In common practice, they are simply "circulators"; they are most often used for low flow rates in small systems. Series 100 type pumps are sometimes called "three piece" pumps since they have an in-line volute, pump bearing assembly, and motor assembly.

### Wet Rotor Circulators

All of the pumps described so far use either oil or grease to lubricate the bearings. A "wet rotor" circulator uses the system fluid.

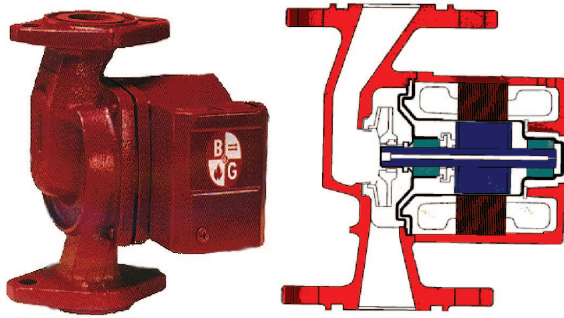

**Series NRF Circulator**  
**Figure 18**

The impeller is attached to the motor shaft, and the whole assembly rotates inside a stainless steel can. The system liquid circulates through the hollow shaft and around the bearings. Circulators like this are limited in size and application because the pumped fluid rarely provides good enough lubrication to handle the loads imposed on the bearings of larger pumps.

### Multi-Stage Pumps

Some pumps use several impellers "in series" in order to apply more work, thus develop greater discharge head.



**Goulds Multi-Stage Pump**  
**Figure 19**

These pumps come with a wide variety of nozzle orientations. Some have the suction nozzle at the bottom, discharge at the top; others have both at the bottom. The shaft has several single suction impellers attached to it. Each impeller turns in a "diffuser".

A diffuser performs the same function as a volute, but it has several cutwaters, and discharges liquid parallel to the shaft. In these pumps, the first diffuser discharges into the suction of the next, applying work at each stage to achieve very high discharge pressures. The same idea can work with volutes too. Figure 20 shows a two-stage volute type pump.

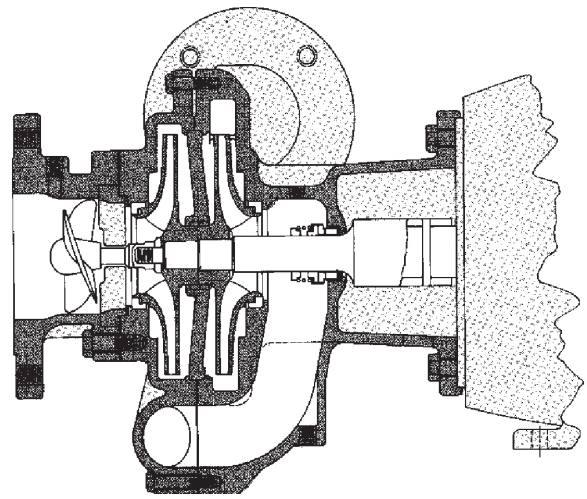

**Domestic Series DB multistage pump**  
**Figure 20**

Discharge from the first impeller is directed to the suction eye of the second, resulting in high discharge pressure. "Domestic" brand pumps are commonly used in steam/condensate systems where the liquid is very close to the boiling point. The little axial flow impeller is called an "inducer". It doesn't count as a separate pumping stage; it merely acts to insure satisfactory performance of the first.

### Vertical Turbine Pumps

Vertical turbine pumps, "VTP", are usually multistage.

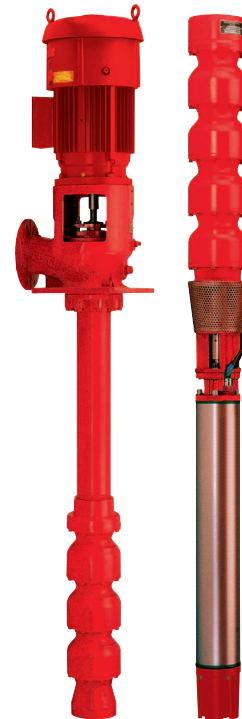

**Vertical Turbine Line Shaft and Submersible Pumps**  
**Figure 21**

The line shaft type usually has several diffuser "bowls", each with its own impeller. The motor is installed at the top; the pumping assembly is immersed in a well, deep enough to insure that the bowls are covered with water. A sealed motor is used with submersible VTPs, the whole assembly is inserted into the well.

## Double suction pumps

Single suction impellers are limited in terms of the flow rate they can handle, so double suction impellers must be used for high flow applications. The horizontal split case pump, "HSC", was developed long ago for this kind of service.

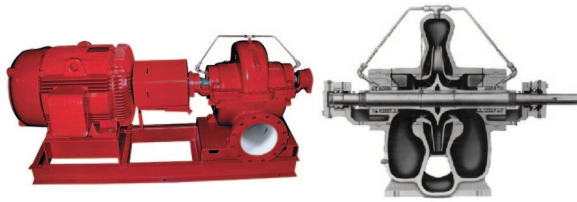

**Horizontal Split Case, Double Suction Pump**  
**Figure 22**

These pumps are typically very large, base mounted, and flexibly coupled. The suction and discharge nozzles are located so the piping must run parallel to the floor. If the flow splits evenly at the suction nozzle; half goes into each impeller eye, and the axial thrust is cancelled. Sometimes the flow isn't equally split, so these pumps are provided with a thrust bearing on the end of the shaft away from the motor, the "outboard end" as it's called. The shaft penetrates the pump casing twice, so two stuffing boxes or mechanical seals must be provided. The unsupported length of the shaft from the bearing to the impeller often resulted in deflections large enough to cause metal to metal contact at the suction eyes, so replaceable "wear rings" were always included in the design.

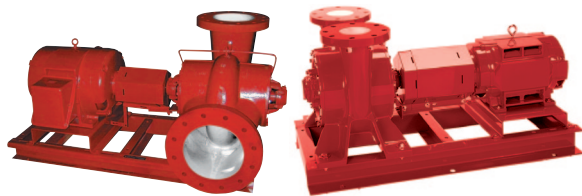

**Vertical Split Case, Double Suction Pump**  
**Figure 23**

Given the difficulties inherent in servicing the HSC design, and the inflexibility in routing the piping, a vertical split case double suction design was introduced in the 1970s. The discharge piping could then be directed upwards, saving space. In some smaller models, the suction pipe could be vertical too. Internally, a shorter unsupported shaft length made wear rings unnecessary and routine service a lot easier.

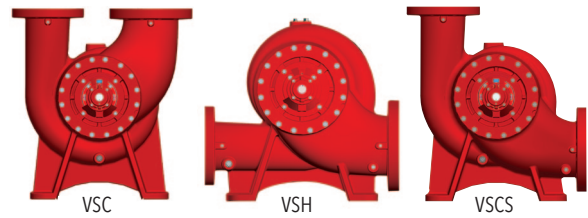

**Bell & Gossett Series VSX**  
**Figure 24**

Modern double suction pumps are specifically designed for high efficiency in building service applications, require very little routine maintenance, and can be installed in any of the three piping configurations shown in Figure 24.

## Pump Installation Details

All pumps must be installed properly in order to:

- provide the design flow and head
- minimize energy consumption
- minimize wear, service requirements, and downtime

General issues in pump installation are covered in other Bell & Gossett training manuals, and the specific details for each pump type are always found in the installation and operation manual, (IOM), provided with the pump. The IOM may recommend certain accessories be installed with the pump. Because these accessories add to the first cost of the pump, they must be considered in the pump selection process too.

## Suction Conditions

All pumps must be provided with "good suction conditions." That's not just a vague comment; in fact, Hydraulic Institute Standard ANSI/HI 9.6.6-2005 spells out several requirements for the suction side of the pump.

- Sufficient pressure to avoid damaging cavitation. This topic is discussed in detail in other Bell & Gossett publications.
- Minimize pump nozzle loading. In general, pump nozzles are not designed to carry excessive static loads. Under load, the volute may undergo plastic deformation over time resulting in leakage or metal to metal contact. Pipe expansion can also impose heavy loads on pump nozzles. Specially designed expansion devices can minimize these loads.
- Avoidance of excessive entrained gas. In closed systems, properly installed air management equipment quickly removes entrained air bubbles. In open systems, entrained gas often presents a more formidable problem. Even a small amount of entrained gas will reduce pump performance.
- Avoidance of strong local currents and swirls.

The HI/ANSI standard states that the "most disturbing flow patterns...are those that result from swirling liquid that has traversed several changes of direction in various planes." Failure to provide satisfactory suction conditions can lead to noisy operation, random axial load oscillations, premature bearing or seal failure, or cavitation damage to the impeller or volute. Ideal suction conditions for clean water systems can be provided by a straight length of pipe, sized to avoid velocities



greater than 8 ft/s. The straight pipe should be at least five pipe diameters long, larger pumps may require up to eight pipe diameters of straight length. Short suction piping, represented by an elbow installed too close to the suction nozzle, can result in excessive bearing loads.

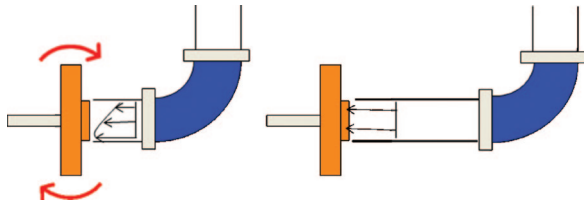

**Increased Bearing Loads Caused By Poor Suction Piping**  
Figure 25

In Figure 25, the elbow on the left is close to the impeller. Inertial effects on the water as it changes direction result in large differences in velocity across the suction eye. "Momentum" is a function of mass and velocity. The difference in momentum across the suction eye exerts a torque, or turning action as shown by the large arrows. The shaft must be short or stiff enough to resist deflection, but the shaft bearings will see increased radial loads in any event. By increasing the length of the suction pipe, on the right, velocity differences even out, reducing shaft and bearing loads. For small end suction pumps, a length of straight pipe at the suction nozzle is not likely to be a problem, but for larger pumps, it is a major constraint in laying out the equipment room. Floor space in building equipment rooms is often limited, since mechanical spaces don't generate rent revenue, or contribute to the building's esthetic appeal.

### Suction Diffuser

A "suction diffuser" provides good suction conditions while minimizing equipment room space requirements.



**Suction Diffusers of Various Sizes and Connection Types**  
Figure 26

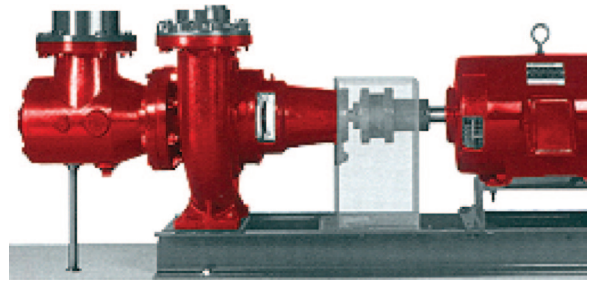

**Suction Diffuser Installed on an End Suction Pump**  
Figure 27

The suction diffuser acts as a transition from suction pipe to suction nozzle size, since the suction pipe is often a size larger than the pump nozzle in order to reduce pressure drop. The suction diffuser is a low pressure drop device, suitable for installation at the pump suction. It also can support the weight of the suction piping to minimize pump nozzle loading. It is usually attached directly to the pump suction nozzle, minimizing floor space requirements.

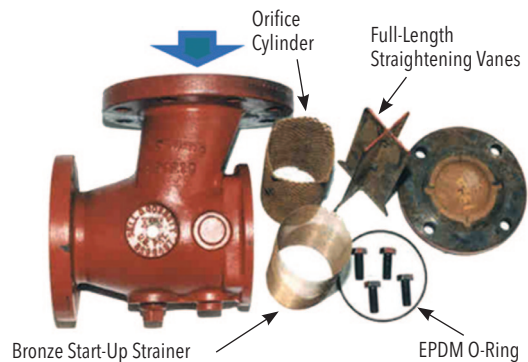

**Suction Diffuser Internal Components**  
Figure 28

The permanent internals include the full-length straightening vanes and orifice cylinder which fits closely around them. Together, they provide uniform velocity, swirl-free liquid flow to the suction eye. Liquid enters as shown, completely surrounds the orifice cylinder and vanes leading to the suction eye. It's important that these components are the full length of the diffuser casting in order to provide evenly distributed flow. The orifice cylinder acts as a coarse mesh strainer, keeping solids larger than  $\frac{3}{16}$ " diameter from entering the pump. A much finer "start-up" strainer is sometimes included with the suction diffuser as a poor alternative to proper system cleaning and flushing. It will remove construction debris and smaller solids brought to it by system flow, but as it clogs, it reduces suction pressure at the impeller eye. Therefore, it's important to remove and discard the start-up strainer along with the debris it has captured. In order to do this, there must be adequate clearance to remove the permanent straightening vane assembly.



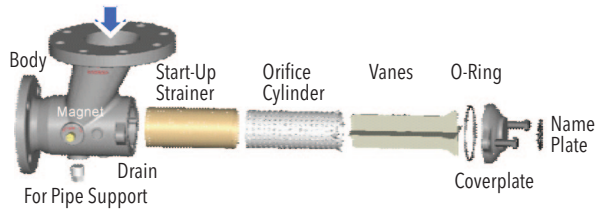

**Exploded View, Suction Diffuser Internals**  
**Figure 29**

**Discharge Conditions**

Compared to the suction side, discharge side requirements are much less demanding. The HI/ANSI standard recommends the discharge pipe be sized for velocity no greater than 15 ft/s, although other factors may be considered too; for example, lower velocity would be recommended if severe hydraulic shock could result when a check valve slams shut on a reversal of flow. A shut-off valve must be installed in order to isolate the pump for service, and a check valve to prevent reverse flow. If pipe expansion control devices are used, they should be placed between the pump and the check valve. The standard allows the use of combined shut-off and check valves, commonly called "triple duty" valves. A throttling valve may be installed on the pump discharge to reduce the excess flow produced by an over-sized impeller.

**Triple Duty® Valves**

Bell & Gossett invented the Triple Duty Valve in order to reduce the space required by a properly installed pump. Historically it combined the shut-off, check and throttling valve functions in a single valve, but modern Triple Duty Valves also act as rough flow meters, and the angle style as an elbow.

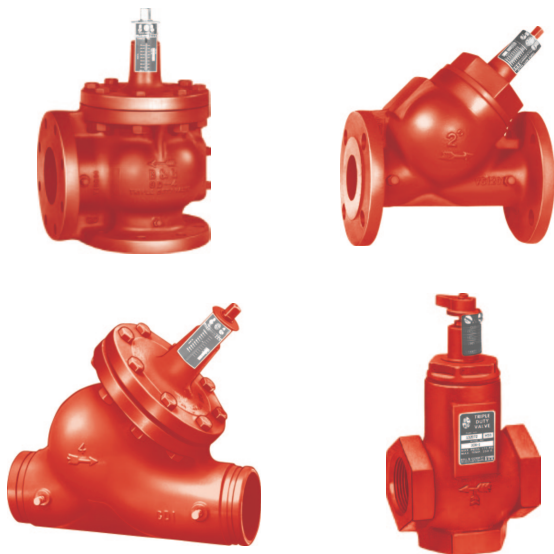

**Triple Duty Valves in Various Connection Types and Sizes. The Valve at the Lower Right is Available up to 1½", the Rest are Available in Much Larger Sizes.**

**Figure 30**

It's obvious that a valve is required at the pump discharge in order to isolate the pump for service, but is a check valve always necessary to prevent reverse flow? In closed loop systems which have only a single pump, reverse flow is not likely to be a problem, but in larger systems where multiple parallel pumps are used, or in open systems which have significant elevation differences, the check valve is crucial. Backward flow through a pump simply wastes money since the water isn't going out to the system as designed. Reverse flow can also damage the pump shaft or motor windings. In reverse flow, the impeller is rotating the wrong way. A large impeller can therefore have significant angular momentum. If the motor comes on in attempt to increase system flow, it will have to slow down and stop the impeller, and then accelerate it in the correct direction. This sudden torsional stress can snap the shaft. Even if the shaft is strong enough to resist damage, the motor windings will see large current draw resulting in heat build-up in the windings.

The third function of a Triple Duty Valve is to act as a "balance" valve. Unfortunately, the word "balance" has several meanings, especially in hydronic systems. In this context it means simply that the valve is used at the pump discharge to reduce the excess flow which will be caused by an over-sized impeller. An impeller that's too large in diameter at constant rpm will apply more work than required by the system. This always results in larger flow rates and greater power consumption. A Triple Duty Valve can be set so that it doesn't open fully when the pump comes on. It's acting as a "discharge throttling valve", converting the excess pump head into noise and turbulence while reducing flow and horsepower. Both the valve manufacturer and ASHRAE have established limits on the amount of discharge throttling that should be applied at a pump. Bell & Gossett limits the discharge throttling to no more than 25 feet of head loss at the valve, or about 11 psi pressure drop for standard water. This limitation reduces the erosion and turbulence in the valve, increasing its lifespan. The ASHRAE energy standard limits discharge throttling to no more than three horsepower. Both of these limitations have the effect of urging designers to avoid over-sized impellers.

**Pump Foundation**

Base mounted pumps must be installed on a rigid foundation which is some multiple of the pump's weight. For small pumps, the manufacturer may require a foundation which is 2½ to 3 times the pump weight. Larger pumps often require even heavier foundations. The foundation must be firmly tied into the building structure. The pump base must be securely bolted to the foundation using anchor bolts that allow some flexibility in aligning the bolt and baseplate holes as shown in Figure 31. Base mounted pumps usually require grouting. The grout is a non-shrinking cement or epoxy based compound that will lock the pump base to the foundation. This has the effect of increasing strength, maintaining shaft alignment, and reducing noise and vibration.

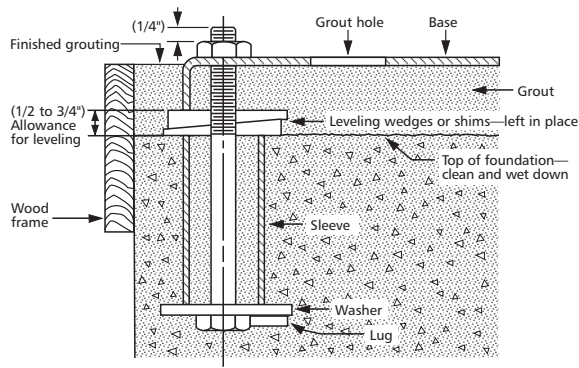

**Section View of Typical Grouted Pump Base**  
**Figure 31**

The pump baseplate must be level, using wedges between the baseplate and foundation as necessary. Some pump bases require a temporary dam to retain the grout until it cures. Other manufacturers build the base with welded ends to make grouting easier.

Some designers prefer to use an inertial base to further reduce the transfer of vibration to the building structure. Note in Figure 32 that the suction piping is also firmly supported.

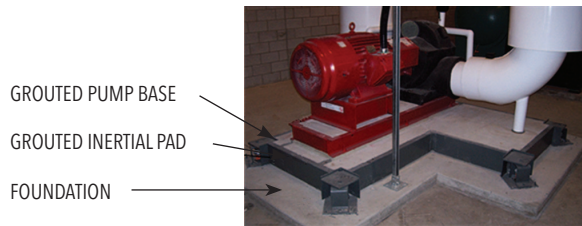

**Typical Inertial Pad Installation**  
**Figure 32**

Very small in line pumps can be supported by the system piping, but larger pumps require additional support. Many close-coupled pump volutes are configured with flange-like adaptors which make it easy to install proper support under the pump.

Seismic restraint is important in sections of the country where earthquakes may occur. These requirements must be met in addition to the standard manufacturer's details.

### Flexible Connectors

Strictly speaking, flexible piping connectors are not required, but they offer many practical advantages in pump installation:

- Minimize the loads acting on pump nozzles by absorbing thermal expansion of the piping
- Reduce the transmission of noise and vibration from the pump to the piping—an especially important point in building service pumps where even minor noise may not be tolerable.
- Provide some tolerance in targeting pipe connections between the pump and system.

Typical flexible connectors are made of braided stainless steel, single or double sphere rubber. All of them are capable of absorbing some degree of relative motion in order to compensate for thermal growth and vibration. Flexible

connectors can always be used with base mounted pumps, but they are required if inertial pads are used.

### Pipe Supports

In general, pumps are not designed to carry the weight of system piping and fluids. Figure 24 shows an important exception in the VSC style pump. Because its nozzles are oriented vertically, they are allowed to carry some static loads. The exact amount is determined by the volute size and listed in the pump technical data. Note that flexible connectors are not designed to carry static loads, so adequate anchors and supports are still important.

### Pressure Gauges

Quality gauges are always required in order to determine if the pump is operating properly. Manufacturers provide gauge taps at the suction and discharge nozzles for this purpose. It's preferable to use a single gauge to measure both pressures, and then subtract suction from discharge pressure. In this way, any gauge error will cancel out.

A special "trumpet valve" is often used to mount the single gauge, allowing it to be used to measure pressure drop across the suction diffuser to detect clogging, and pressure rise across the pump as in Figure 33.

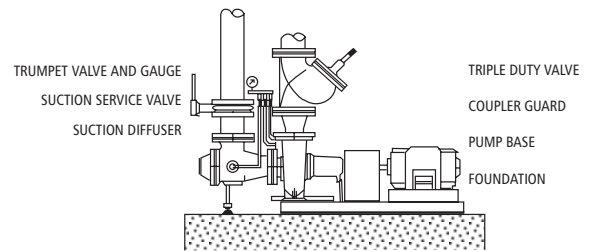

**Typical Base Mounted, End Suction Pump Installation**  
**Figure 33**

### Summary

Good installation will minimize operating problems and reduce operating costs over the life of the pump. Some installations are simple, others require considerable expertise, but the installer must always follow the manufacturer's installation literature. The brief discussion in this manual is important background to the primary topic—selecting the appropriate pump for the system.

### Life Cycle Costs

Centrifugal pumps are simple, and robust, especially in clean water building service. The pump's service life is measured in decades. During those years, the pump may require repair, it will need routine maintenance, and it will certainly use increasingly expensive electrical energy. All of these costs must be added to the initial procurement and installation costs in order to calculate the "life cycle cost" of ownership. This is an important issue in pump selection: the installed cost of the pump is usually a small fraction of the overall life cycle cost of owning and operating the pump. The Hydraulic Institute has published a very useful guide to the topic, "Pump Life Cycle Costs: A Guide to LCC Analysis for Pumping

Systems". HI has also developed a one-day seminar on Pumping System Optimization: Opportunities to Improve Life Cycle Performance. More information about these resources is available at the HI website, [www.PumpSystemsMatter.org](http://www.PumpSystemsMatter.org). The HI Guide recognizes the time value of money in calculating the pump life cycle cost. It discusses the most common financial measures used for ranking investment opportunities; because the selection of a large pump should be considered as a long term investment, competing with many other possible investments for limited funds.

From a life cycle cost point of view, the process of pump selection takes on added importance. A good pump selection will obviously minimize energy consumption over its lifetime, but a properly selected and installed pump will also provide increased reliability, minimizing interruptions in service, maintenance costs and overall life cycle costs.

Pump selection is an important part of the overall system design. There is often some degree of uncertainty in the design process, but the pump must be selected in spite of this uncertainty. System design guidance is available in other Bell & Gossett publications, so it will not be covered in detail here, but there are important strategies that can be applied in the face of uncertainty. This publication will discuss these strategies. After the system is built, all the uncertainties in the design process disappear—because the actual performance of the system can be measured. This is traditionally the role of the test, adjust, and balance (TAB) contractor or "commissioning engineer", who carefully measures important operating parameters such as flow rate, motor horsepower usage, etc. and then adjusts the system as required. Performance testing and adjustment are critical in reducing life cycle cost and providing the expected service. Suppose a replacement pump must be provided for an existing system. The flow rate and the system head at design flow can be easily measured, so there's little uncertainty in the selection process, and we'll see that the selection strategy changes accordingly. In any system, routine inspection and service as required will also reduce life cycle costs.

During the commissioning process it may be determined that the installed pump has been oversized—its impeller is too large. It's too late to remove the pump and replace it with a smaller one, so this is where impeller trimming can be used to improve the performance and reduce the operating cost of the oversized pump. In practice, impeller trimming is probably not employed as often as it should be given the tendency to oversize building service pumps. If the pump has been selected to operate at variable speed, impeller trimming becomes far less important in terms of reducing energy waste, but it's still important to select the right impeller diameter even with variable speed.

### **Pump selection as a decision-making process**

The system served by the pump determines most of the important factors in pump selection. The designer must analyze the system in order to make sound decisions about:

- **The Type of Pump.** The types of pumps normally used in building service were described briefly above. Often, there

are several different pump types that could provide the required system head and flow, so the designer must be aware of the characteristics of each pump type, and then decide how these characteristics meet the requirements of the specific system. Differences in cost, space available for installation, maintenance requirements and costs, and the experience level of the operators are all factors to be considered.

- **Volute Size.** Most of the pump types come in a range of sizes. Remember that the discharge nozzle size usually designates the volute size.
- **Impeller Diameter.** In small pumps, the impeller diameter is often fixed for a particular volute. In larger pumps, the impeller diameter may be trimmed in  $\frac{1}{8}$ " or  $\frac{1}{10}$ " increments from maximum to some minimum. In some pump types, there may be a choice of impeller materials or designs, e.g. impellers that have a "steep" or a "flat" head-capacity relationship.
- **Mechanical Seal.** The materials used in seals for building service pumps are selected by the pump manufacturer for typical conditions of system temperature, pH, and concentration of dissolved and suspended solids. A given system may have unusual conditions that would require special seals.
- **Pump Pressure Rating.** The pump's pressure rating is simply a measure of its ability to contain internal pressure. The rating is determined by such things as the thickness of the metal walls, the flange and gasket design. Although the head generated by the pump is one factor in determining the internal pressure, other factors like the system static pressure and the water temperature must be considered too.
- **Motor Type and Size.** Small pumps often come equipped with a motor which can supply enough horsepower to operate anywhere on its head-capacity curve. In larger pumps, the designer must select the motor. Large motors can represent a significant fraction of the pump's cost, and often cause large increases in procurement lead time. Sometimes, the motor must be selected for unusual or even hazardous conditions. Special motor enclosures are available to allow operation in areas where water or dust could enter the motor windings resulting in early failure. These special motors are not often found in building service, but where they are needed, they impose another set of restrictions on the designer.
- Finally, the designer must make all these decisions with the owner's budget and competitive pressures in mind. While the initial cost of the pump and system is undoubtedly important, all too often the initial cost is given far too much weight in the selection process. Considering the life-cycle cost of ownership results in better decisions.

## Pump Selection for Known Flow and Head Conditions

Impeller specific speed generally dictates the shape of the pump's head-capacity curve. More detailed information about the wealth of data available from a manufacturer's pump curve is available in other Bell & Gossett publications.

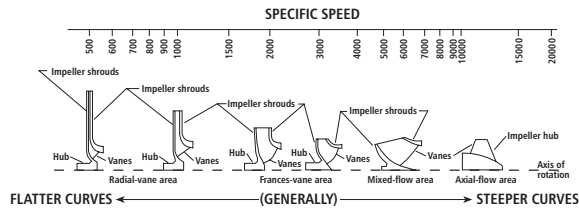

**Specific Speed and Impeller Profile**  
**Figure 34**

The shape of the pump curve can be an important selection parameter. It shows how head varies with flow for that specific pump. The pump must operate on its curve.

## Fixed Flow System

Suppose a system has a fixed flow and head requirement. The shape of the pump curve is irrelevant, and the designer should select the most efficient impeller and volute in the suitable pump type.

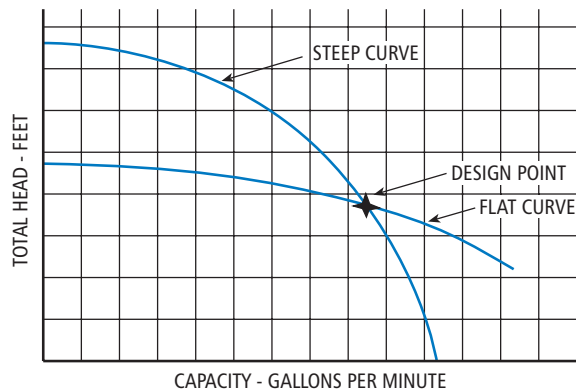

**A Steep Curve and a Flat Curve Pump for a Given Design Condition**  
**Figure 35**

## Variable Flow System

More commonly, system flow will change as control valves open and close. Two-way control valves may be two-position (on-off), or may modulate. Both kinds are used in building service making the system "variable flow". An obvious example is the building domestic water distribution system with flush valves, faucets, dishwashers, etc. We can see the effect of variable volume valves on the system pump by using the "system curve". Just as a pump curve represents the action of the pump in increasing total fluid head, the system curve shows how the system uses head to overcome differences in pressure, elevation, velocity, and offset the losses due to friction.

## Variable Flow, Fixed Head System

In this special case, the system requires the same fixed value of head at a fixed point in spite of flow variations, so the system requirements could be represented by a horizontal line. In domestic water systems, it's often best to maintain a fixed pressure at the top of the system. The required pump pressure would be the sum of elevation differences, in pressure units, from bottom to top, plus pressure differences between the city supply pressure and the pressure required for plumbing fixtures at the top plus the pressure drop due to friction in the piping under maximum flow demand.

## System Curve

Bernoulli's equation was the basis for the discussion of how a pump applies work to the fluid in order to increase total fluid head, but in that discussion, we pointed out that fluid friction was ignored. In fact, some of the fluid head is always converted to heat by the process of overcoming shear forces at the fluid-pipe wall boundary, and within the fluid itself. The Darcy-Weisbach relation was developed empirically to account for fluid friction in a pipe. There are other, similar expressions for fluid friction, but the Darcy-Weisbach form is most commonly used in hydronics.

$$h_{\text{friction}} = f \frac{L}{D} \left[ \frac{v^2}{2g} \right]$$

Where:

$h_{\text{friction}}$  is the head loss in foot-pounds per pound of fluid, or feet of friction head loss

$f$  is the "friction factor" usually obtained from a Moody chart

$L$  is the length of the pipe in feet

$D$  is the diameter of the pipe in feet

$V$  is the average velocity across the pipe flow area in feet per second

$g$  is the gravitational constant, 32.2 feet per second per second



## Moody Chart

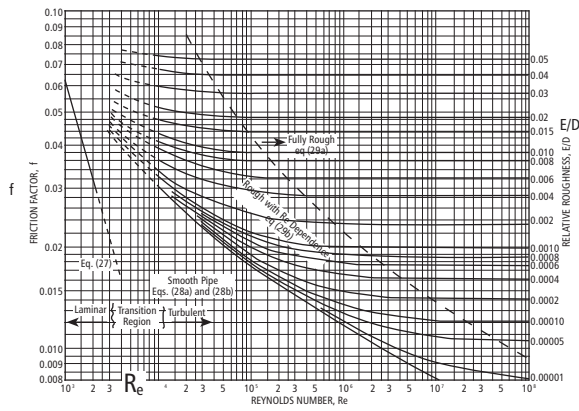

**The Moody Diagram  
Figure 36**

The Moody friction factor,  $f$ , is plotted on the vertical axis. The horizontal axis is the Reynolds Number,  $Re$ , a dimensionless number that includes things like the fluid viscosity or resistance to shear, the fluid velocity, and the pipe diameter. Low values of  $Re$  result in "laminar flow". We can think of low  $Re$  situations by picturing a very slow, or a very viscous fluid passing through a large diameter pipe. The velocity of a small volume of fluid is parallel to the axis of the pipe, and there is no component of velocity at right angles to the axis. Under these unusual conditions, " $f$ " is related to  $Re$  in a simple linear fashion as represented by the straight line labeled Eq. 27 in Figure 36. Building service systems are not designed to operate in laminar flow.

As the velocity of that small fluid volume goes up with smaller pipe size, or its viscosity goes down,  $Re$  increases, and we move from the laminar through the transition region into the turbulent flow region. In this region, the roughness of the pipe wall begins to affect the friction factor. This is represented by the family of curves which slope down and then become horizontal at higher values of  $Re$ . Each of these curves represents a "relative roughness",  $e/D$ . The " $e$ " value represents the smoothness of the pipe wall; a rough pipe would have a larger value of  $e$ . But in a large diameter pipe, very little of the fluid is in contact with the pipe wall. Most of the fluid is in contact with other fluid, so the roughness of the wall becomes less important. Most building service systems are designed to use relatively smooth, commercially available pipe. The pipe diameter is selected according to the flow it will carry so that the combination of  $Re$  and  $e/D$  will result in a friction factor in the transition or turbulent region. Table 1 was constructed using the Bell & Gossett System Syzer to show the variation of " $f$ " in real systems. Pipe size and flow rates were selected to maintain the friction loss rate in the range of 0.85 to 4.5 feet of head loss per 100 feet of pipe length, a typical design criterion for hydronic systems.

Schedule 40 Pipe Size	Flow Range gpm	Friction Factor
1	4-7	0.0329-0.0296
2	20-49	0.0261-0.0228
4	118-287	0.0207-0.0185
6	352-847	0.0182-0.0166
8	727-1741	0.0168-0.0154

**Table 1**

For any given, fixed piping system, all the factors in the Darcy-Weisbach relation can be considered to be constant, e.g. the length, diameter, and gravitational constant. From Table 1, we can see that friction factor doesn't change a great deal in the normal flow range. Therefore:

$$h_{\text{friction}} = \text{Constant } v^2$$

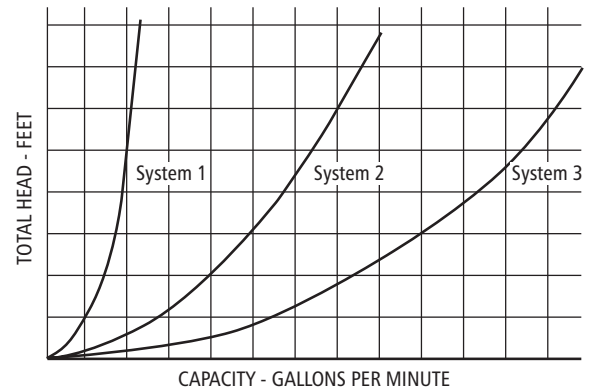

**System Curves Showing Head Loss Versus Flow  
Figure 37**

All three systems in Figure 37 have the curvature characteristic of second order equations because velocity increases with flow rate, and head loss increases as the square of the velocity, but System 1 has a large value for the constant—it's a high friction loss system possibly because it was built with smaller diameter pipes. Systems 2 and 3 have smaller values for the constant, possibly because they were built with larger diameter pipes.

In a given piping system, the average velocity of flow will change as valves in the system open and close, so we could re-interpret Figure 37 as a single system with two-way control valves. If all the valves are open, the system looks like a low-resistance System 3. As the valves close, they change the system so that it looks more like System 2 or System 1.

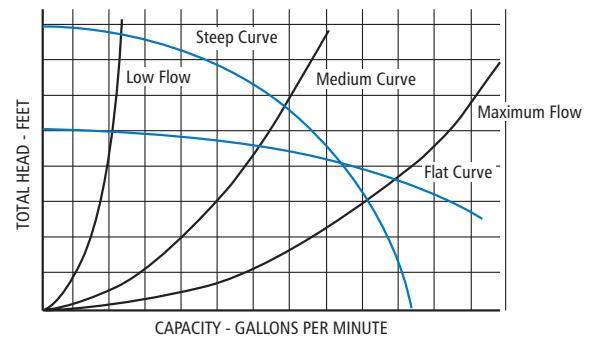

**Variable Volume System with Steep and Flat Curve Pumps - Figure 38**

Figure 38 can be used to illustrate another very important consequence of Bernoulli's Principle. The variable volume system curves are now superimposed on the pump's head-capacity curve. The intersection of the pump curve and system curve always defines the flow through that pump in that system. Both the flat and the steep curve pumps have intersections with the system curve at high, medium, and low flow, so either pump would be able to operate in the system as flow varies from maximum to minimum. If a given pump curve cannot intersect the system curve, pump operation will be unsatisfactory, and damage to the pump will eventually cause it to fail.

### "Riding the Curve"

As system flow decreases from maximum to minimum, the intersection of the pump curve and system curve occurs at lower flow rate and higher head. The term "riding the curve" is often used to describe this kind of situation. For a flat curve pump, the increase in head is moderate, for the steep curve pump, it's large. In fact, the terms "flat curve" and "steep curve" are sometimes defined by the percentage increase in head compared to the head at best efficiency flow as the flow goes toward zero. Steep curve pumps increase head by more than 25%, flat curve pumps increase less than 25%. The designer's choice of pump curve shape could have an adverse effect on the operation of automatic control valves.

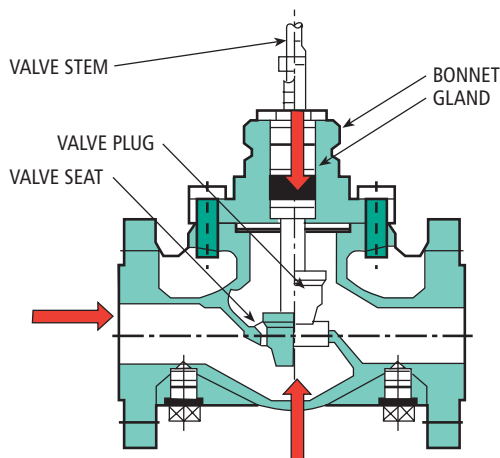

**Typical Globe Style Control Valve  
Figure 39**

The valve stem moves vertically through the packing gland in the bonnet as an actuator responds to a signal from an automatic control system. Often it's a simple thermostatic system designed to maintain room temperature. The movable valve plug fits in the stationary valve seat forming a ring, or annular area for the water to flow. If the stem is all the way up, the flow area is large. If the valve stem is down, the area is zero. Flow rate through the valve is determined by that area and the difference in pressure across it. The water exerts a force on the valve plug equal to the area of the plug multiplied by the difference in water pressure across it. Valves like this must always be installed with flow coming in against the valve plug so that the valve actuator closes against the flow. If it's installed with flow acting in the same direction as

the actuator, the valve would slam shut as the sum of actuator force plus water pressure increases. Figure 40 shows the pump and valve interaction.

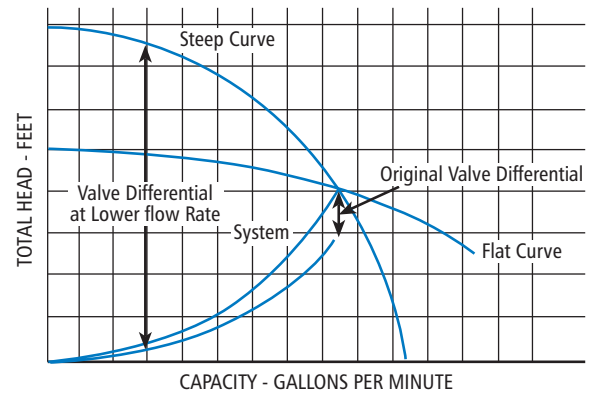

**Pump and Valve Interaction  
Figure 40**

Figure 40 shows two system curves. The lower one represents the head loss in all the system components except the control valve. The upper one includes the differential head across the valve when it's wide open, the original valve differential. As the valve closes, flow and head loss in the rest of the system decreases as the square of the flow change, but the differential across the valve increases as the new system curve rides up the pump curve. A flat curve pump would limit the increase in differential as the valve closes. A steep curve pump may impose such a large differential, that the actuator may not be able to overcome the pump to close the valve.

Figure 41 displays lines of constant horsepower as well as the pump and system curves.

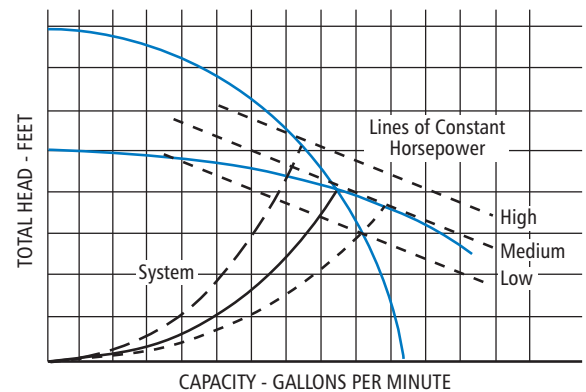

**Pump Curve Shape and Horsepower  
Figure 41**

The flat curve pump has an advantage over the steep curve pump in that it will use less horsepower as the valves close and system flow is reduced. The steep curve pump has an advantage in limiting the increase in horsepower if flow should increase from the design point. Pump manufacturers recognize the need for a variety of pump curve shapes. They sometimes provide different sets of impellers for the same volutes in order to give designers a choice between flat and steep curve performance.

## Volute Choices

### Base Mounted Versus In-Line

If the same impeller performance can be obtained in two different volutes, then the designer must make yet another choice. For example, an in-line pump versus a base mounted pump.



**Bell & Gossett Series 1510 Base Mounted and Series 80 In-Line Pumps**  
Figure 42

In-line pumps have the advantage that they do not need to be mounted on a concrete floor pad, although they do have to be fully supported in the piping system. In regions where seismic restraint is important, that could be a disadvantage for large in-line pumps. Smaller in-line pumps probably need less floor space than an equivalent base mounted pump, but in larger sizes, they may actually require more space in order to perform satisfactorily and provide room for routine service. Smaller in-lines may cost more than the equivalent base mounted pump, although the additional cost of pump accessories like suction diffusers must be considered too. Base mounted pumps often benefit from the use of a suction diffuser, in-line pumps only need them occasionally. Pumps are not fragile, they do not require a great deal of service, but routine lubrication and repair is probably easier and less costly with base mounted pumps, especially in larger sizes.

### Flexibly Coupled Versus Close Coupled



**Bell & Gossett Series 1510 Flexibly Coupled and Series 1531 Close Coupled Pumps**  
Figure 43

Prices are comparable for these types (Figure 43). Both require a foundation pad, although the close coupled pump will probably take up less space. Shaft alignment is not necessary for the close coupled pump, but the flexible coupler makes routine maintenance much easier, and provides quieter operation of flexibly coupled pumps. The coupler also acts as a kind of shock absorber to dampen the torsional stress in variable speed systems or in tower systems that contain large air bubbles. Special motors are required by the close coupled pump, which also limits their application range.

## Single Suction Versus Double Suction



**Bell & Gossett Series 1510 and Series HSC**  
Figure 44

Single suction pumps are limited in flow rate by the axial force that builds as water flows into the impeller suction eye and changes direction radially. Double suction pumps can handle significantly higher flow rates without fear of axial thrust as long as the flow is evenly distributed to both sides of the impeller. Still, there is a flow range where either type of pump could be used. Single suction pumps are less expensive, double suction pumps have lower NPSHR since each suction eye handles only half the flow. Older double suction volutes had horizontal suction and discharge piping. Newer designs had combinations of horizontal and vertical nozzles. The large variety of double suction volutes, each with its unique nozzle arrangement, has been replaced by a more flexible volute design that uses any of three nozzle arrangements for the same set of head and flow performance characteristics.

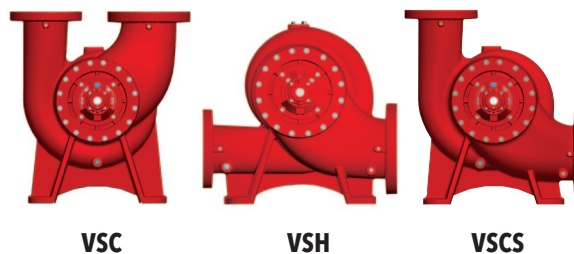

**Bell & Gossett Series VSX**  
Figure 45

This latest generation of double suction pumps has an advantage over older designs in terms of smaller size and lower maintenance costs over the pump's life cycle.

### Selection Strategies

Once the volute type is selected, the designer must make additional decisions about the size of the volute, the impeller diameter, and the motor size and type. In making these decisions, the pump's "best efficiency point" should be used as a reference

### Best Efficiency Point and Preferred Selection Region

Every impeller has some flow at which it is most efficient, the "BEP", or "best efficiency point". A given impeller and volute together determine the shape and size of the gap between them that collects the high velocity water from the impeller blade tips, and channels it toward the discharge nozzle. Flow rates less than this best efficiency flow will encounter losses due to internal recirculation, flow rates greater than best efficiency will encounter higher friction loss. Typical centrifugal pumps have a range of flow rates where the sum

of friction and recirculation losses is at a minimum. This range is not centered on the best efficiency flow, but is offset to the left of best efficiency. The 2008 ASHRAE Handbook, HVAC Systems and Equipment, Chapter 43 illustrates this low loss area and the preferred selection region.

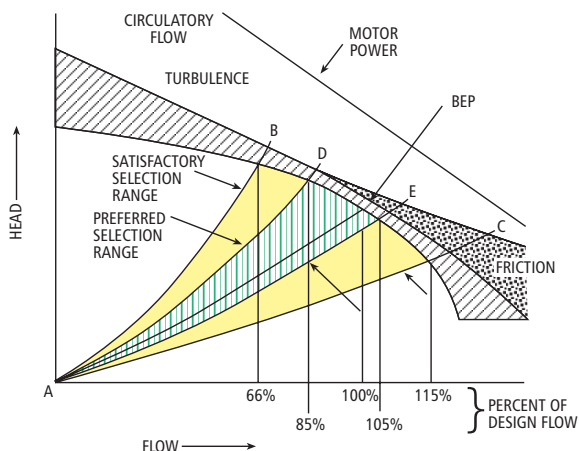

**Preferred Selection Regions**  
**Figure 46**

Pumps that operate in the preferred selection region will be more efficient, and will encounter fewer maintenance problems over their life cycle compared to pumps that operate for long periods outside of that region.

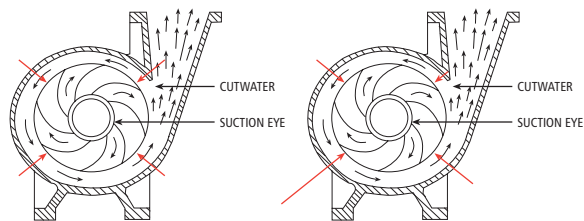

**Radial Forces Increase Away From BEP**  
**Figure 47**

Pumps are not fragile; the increasing radial forces exerted on the shaft will not necessarily cause damage or shaft deflection, provided that the shaft is stiff and strong enough to counter them.

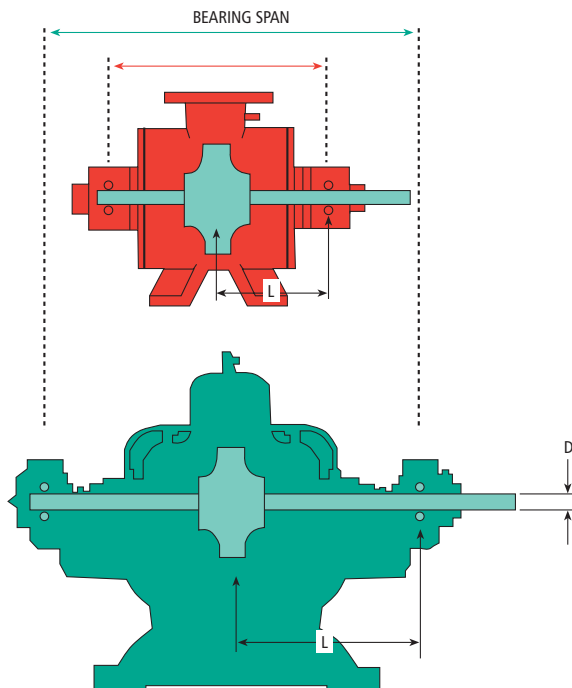

**Bearing Span and Shaft Diameter**  
**Figure 48**

Pumps with short, large diameter shafts resist radial forces without deflection, and reduce the possibility of damage due to metal to metal contact. The ratio:

$$\frac{L^3}{D^4}$$

is a measure of the shaft stiffness, its ability to resist radial loads. Of course the shaft bearings must react to these loads, so even though the shaft may not bend, high loads will cause more rapid bearing wear and eventual failure over the life of the pump.

In summary, long periods of operation well below BEP increase operating cost due to lower efficiency, and increase bearing loads. Very low flow can result in overheating. A rule of thumb defines minimum flow as 25% of best efficiency flow. A better definition of minimum flow for specific Bell & Gossett pumps is found in the Bell & Gossett ESP Plus Selection Program in the pump details section.

Long periods of operation above BEP result in lower efficiency, high radial loads as well as increased NPSHR and frictional or flow separation noise.

#### Maximum Impeller Diameter Limits

Often, the largest impeller that can be installed in a given volute will also be the most efficient, but it may also generate noise that would be unacceptable in a building service application. This noise frequency is a function of the motor rpm and the number of impeller vanes that sweep across, close to the cutwater. Some designers write specifications that attempt to avoid this noise by limiting the impeller diameter to 85% of the maximum. All too often, these specification limits are not reviewed resulting in poor pump selections.



## Example

Suppose a building service pump is required for 1750 gpm at 140 feet of head. A standard four pole motor is specified along with a limit of 85% of the maximum impeller diameter.

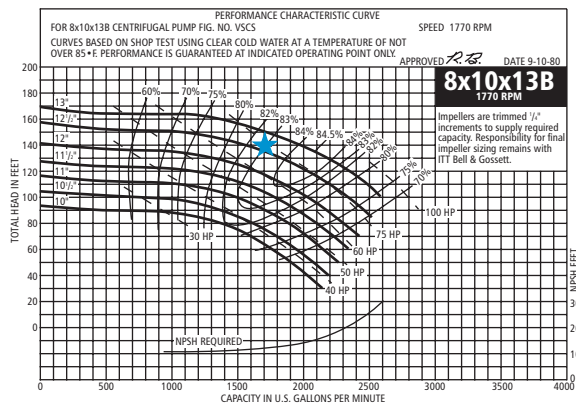

**A Good Selection**  
**Figure 49**

This 8x10x13B pump is 83% efficient, and would use 74.5 hp at the specified point of operation. It uses a 12.75" impeller, 98% of the maximum diameter, and therefore not in accordance with the specification. A larger, more expensive, 8x10x17 pump would be required in order to meet the impeller diameter limitation.

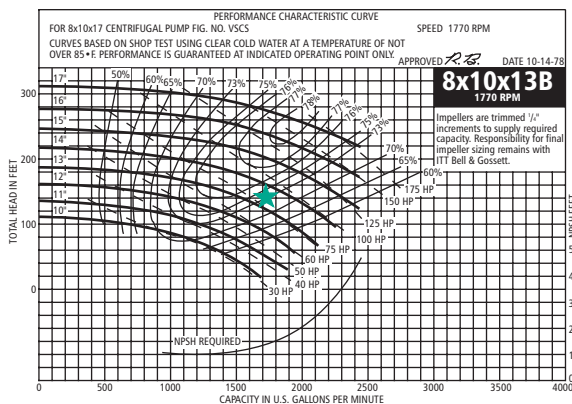

**A Selection to Meet the Specification**  
**Figure 50**

The impeller would have to be trimmed to about 13.5" to meet the design point, but trimming the impeller reduces its efficiency to 73%, increasing the horsepower to 84.5 hp. Therefore the impeller limitation has resulted in applying a larger, more expensive, and less efficient pump. Of course it's not likely to generate noise, but a closer look at the original pump would reveal that it wouldn't be noisy either! The reason is that Bell & Gossett takes noise generation into account when they determine the maximum impeller diameter for the pump curve. This practice may sacrifice a little bit of efficiency in a noisy impeller in order to provide better selections overall.

## RPM Choices

A motor's "synchronous speed" is the number of revolutions per minute made by the rotating magnetic field. It's determined by the number of magnetic poles in the motor winding interacting with alternating current power. The three most commonly used motor speeds are:

- Two pole, 60 Hz motors that run at 3600 rpm
- Four pole, 60 Hz motors that run at 1800 rpm
- Six pole, 60 Hz motors that run at 1200 rpm

In some countries electrical power is distributed at 50 Hz. This will cause a 60 Hz motor to operate at 5/6 of its synchronous speed.

Actual motor rpm will always be a little less than the synchronous speed since motor bearings and air resistance apply torque to the motor shaft tending to slow it down below the synchronous speed. When the motor is driving a pump, the torque becomes greater with increasing flow, making the actual rpm even lower.

Pump generated noise is an issue with pumps that run at 3600 rpm. Even properly installed, carefully aligned pumps may generate audible noise as the impeller vanes pass the cutwater at high frequency, causing some designers to avoid their use. Still, there are some applications where a 3600 rpm pump is an excellent choice in spite of the "singing".

Two pole, 3600 rpm motors can use a smaller diameter impeller for a given operating point compared to a four pole, 1800 rpm impeller. The smaller impeller has only one quarter the weight and only 1/16th the angular inertia. That makes high rpm pumps ideal for intermittent service since they come to operating speed much faster, with consequent reduction in heating of the motor windings. They are also capable of meeting very high head applications without resorting to multi-stage pumps.

By far the most popular design is the four-pole, 1800 rpm motor. It is an excellent choice for most building service applications, combining quiet operation, low stress on shafts, bearings, and couplers. These motors are more readily available when it becomes necessary to replace a motor.

Motors that have six poles are unusual, but not completely unknown in building service. They are well suited to applications that require low head, but high flow rates.

## Pump Selection-General Considerations

**Pump Location:** If a pump will be installed in a sub-basement or equipment room, pump generated noise is not likely to be a problem. OSHA has defined hazardous noise conditions, but pumps typically don't generate anywhere near that level of noise unless there is something very wrong with the bearings or the installation. On the other hand, small pumps may be installed in plenums or close to occupied areas where even a small amount of noise may be objectionable.

**Available Space:** Equipment rooms tend to be small since valuable floor space in commercial buildings must be devoted to revenue producing activities. As the building ages, more equipment may be installed, making space even more critical. Some pump types require a larger “footprint” than others, so designers may weight this factor very heavily in making their decisions. Sometimes, they make compromises, installing the pump where there simply isn’t enough room. Inadequate piping, especially on the suction side of the pump, can result in poor performance and even premature failure as discussed earlier. In addition to the installed footprint, it’s wise to consider the space required for maintenance access. Some pumps require more extensive routine service than others. If poor installation has made it difficult or expensive to conduct routine lubrication or alignment checks, then these checks will be performed less often than required, leading to early failure, downtime, and increased maintenance costs.

**Maintenance Requirements:** Some pump types require a high degree of skill or special tools in order to replace seals, bearings, or other components. They may require beam clamps or tripods in order to move heavy components. Other pump types are virtually maintenance free, or they are made in such a way as to require only minimal skill and no special tools to perform the maintenance. The number and skill level of the operating/maintenance staff, the likelihood of staff turnover, should also be considered along with these other factors when deciding among pump types for a given application.

**Reliability:** In spite of all the comments in this book about pump wear and failure, centrifugal pumps are really quite robust. They don’t fail immediately in the face of poor operating conditions or faulty installation, rather, the life cycle cost of owning the pump increases with downtime, increased maintenance and early component replacement. Pump reliability is increased with proper selection, installation, and maintenance. It can also be increased by using high quality pumps, applying pumps in parallel, using small “jockey” pumps, or installing redundant or “backup” pumps.

**Hydraulic requirements:** The pump selection decision process can’t begin until the designer has determined the required flow rate and head required by the system. The designer must also decide if the pump will see constant or varying flow, the “load profile” or pattern of system use, the properties of the fluid being pumped, and perhaps the NPSH Available to keep the pump from cavitating. Pump selection is really an integral part of the system design process.

## System Design

Other Bell & Gossett publications discuss the hydronic design process in great detail, but it can be summarized in the following:

**Step 1.** Calculate the system heat loss or heat gain using acceptable standard methods, and considering the building’s design purpose, location, and construction budget.

**Step 2.** Select some of the major equipment. For example, heat transfer devices and boilers can be selected largely on the basis of the heat load. Chillers and cooling towers require a more detailed analysis.

**Step 3.** Decide what kind of piping system will be used. Several alternatives are available, each has its own advantages and dis-advantages. These are discussed in other Bell & Gossett publications

**Step 4.** Determine the required flow rate to satisfy the heat load. The properties of the fluid and the design temperature change are the most important additional decisions required at this point.

**Step 5.** Size the piping. Knowing the pipe system layout, the required flow rate in each section can be easily determined. Standard pipe size for each section can be selected by using friction head loss rate or velocity constraints. The Bell & Gossett System Syzer® speeds the process.

**Step 6.** Select the pump for total system flow and head loss in the highest head loss circuit. Superimpose this required operating point on a pump curve of a type which is suitable in your judgment. Once the pump type and volute size is determined, select the impeller diameter and motor size.

**Step 7.** After identifying several suitable alternatives, choose the one which is likely to have the lowest life-cycle cost. Computer based applications are available to help in this process.

### For example:

A closed loop chilled water system in a large university will use two-way valves to control part load performance of the heat transfer equipment. It requires 1200 gpm and the highest head loss circuit will require 80 feet of pump head. Use ESP Plus. The first screen in ESP Plus would look like Figure 51.

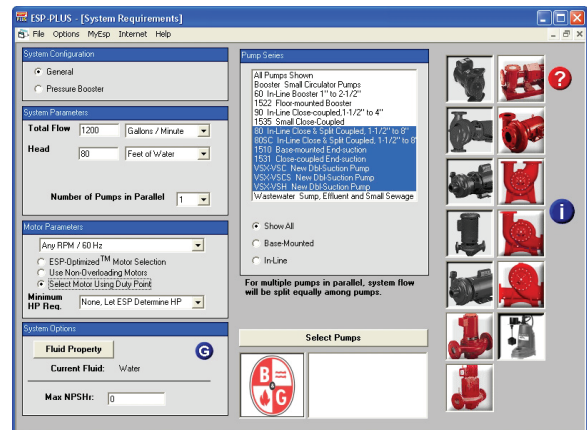

**Initial Screen, ESP Plus  
Figure 51**

The design values for head and flow have been entered in appropriate units, gpm and feet. Other units are also available. A single pump will be selected for this example, but ESP Plus can also select parallel pumps and model their operating costs too. In the Motor Parameters section, “Any RPM/60 Hz will allow ESP Plus to evaluate all three standard motor types. In System Options, we’ll use the default value for water with a specific heat and specific gravity equal to one. In this closed loop, pressurized system, a detailed NPSH analysis is probably not required. In systems with limited NPSHA, the “Max NPSHr” input would limit the pump selection to those

pumps with an NPSHR less than the Maximum value input. A large variety of pump types can be evaluated: in-line, close coupled and flexibly coupled end suction, as well as double suction pumps will be evaluated. Pushing the "Select Pumps" button will immediately present a list of pumps for the designated conditions.

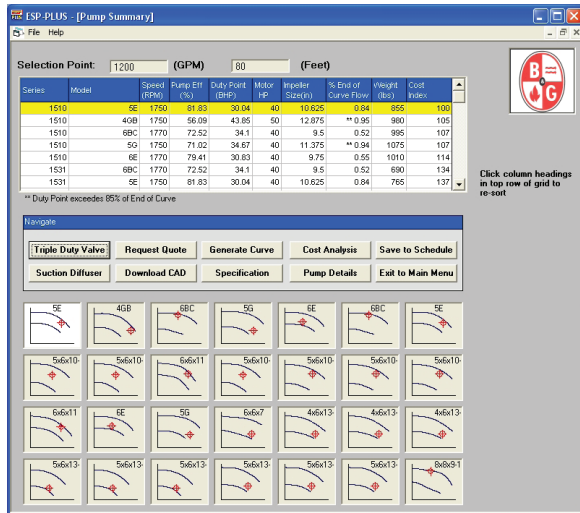

**ESP Plus Pump Summary by Cost Index**  
Figure 52

The design point is shown at the top. Pumps have been ranked by cost by pushing the Cost Index button with the lowest cost pump, a flexibly coupled, end suction Series 1510 5E at the top. The little thumbnails below the list give an idea of where the design point falls on the pump curve. In this case, the Series 1510 is not a very good choice. The Series 1510 is really too small for this application, it's operating at the far end of its curve. The double asterisk in the "% End of Curve Flow" column gives the same indication. The pump would be operating within 16% of the end of the curve, with consequent high radial loads on the bearings. It's also only 82% efficient, using 30.04 hp at the duty point. By pushing the "Pump Eff" button, ESP Plus will re-rank the pumps by efficiency.

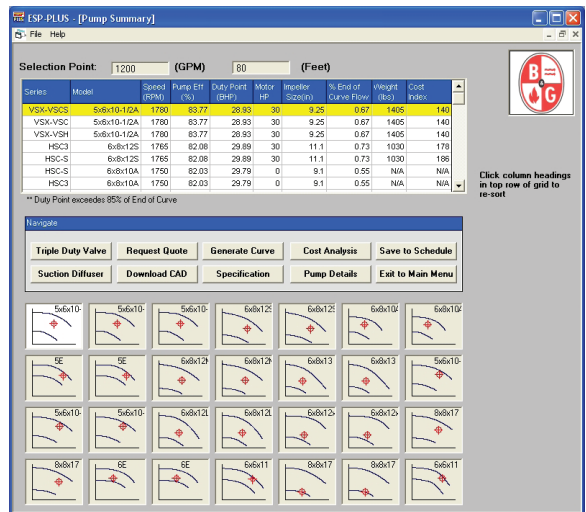

**ESP Plus Pump Summary by Efficiency**  
Figure 53

Now, the more efficient, but more costly double suction Series VSX 5x6x10.5 pump heads the list. It uses less horsepower for the same design point, and it operates closer to the middle of its curve. The user can set up ESP Plus so that pump operating too close to the end of the curve will not appear in the summary.

Pushing the "Generate curve" button will display the pump curve, duty point, and system curve.

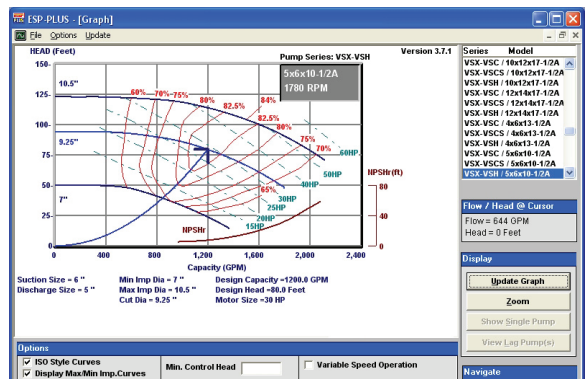

**ESP Plus Pump Curve and System Curve**  
Figure 54

This looks like a pretty good selection, but other pumps could also be quickly examined. The friction only system curve can be displayed too. Note that the design point is very close to the best efficiency that pump impeller can achieve.

Uncertainties often arise in calculating the required head in new systems. People cope with uncertainty by adding a safety factor. Suppose the designer added a 44% safety factor for a total head of 115 feet instead of 80 ft. That would require the largest diameter impeller in this volute, and the system curve would change as shown in Figure 55, intersecting the 10.5" Impeller at 1200 gpm, 115 feet.

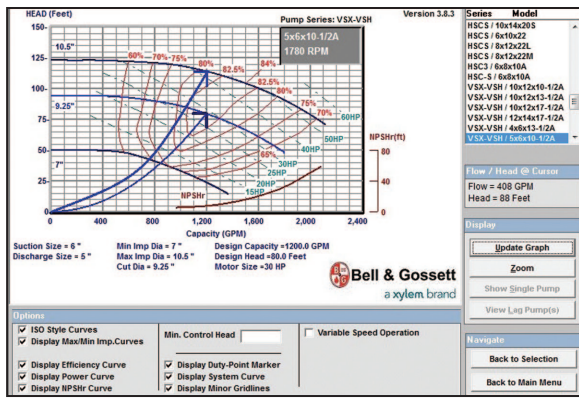

**ESP Plus Pump Curve with Safety Factor System Curve**  
**Figure 55**

Figure 55 illustrates the reason behind a very common pump selection strategy. For constant speed pumps, it's often wise to select a little to the left of the BEP. The low loss region of the pump is not centered on the best efficiency flow, it's offset to the left as discussed earlier. Suppose a large safety factor was included in the analysis of pump head, but the actual system head loss was smaller. The pump and system always operate at the intersection of the two curves, so the point of operation will actually shift to the right if the actual head loss is less than expected. If the pump were to be selected right at best efficiency flow, it could shift to the right, out of the low loss region. If the pump is being selected for an existing system, there's no uncertainty in determining pump head since it can be measured. In that case, select the pump as close to best efficiency as possible, especially in a constant flow application.

Note that the 9.25" impeller at the design point lies just below the 30 hp line. ESP Plus can also aid in selecting the motor size. Pushing the "Pump Details" button on the summary screen yields a wealth of important information about this pump.

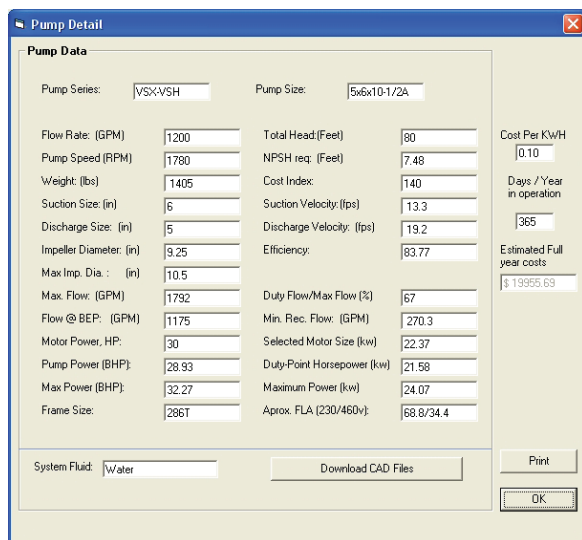

**ESP Plus Pump Details**  
**Figure 56**

These details apply the Series VSX 5x6x10.5 pump operating at 1200 gpm and 80 feet of head. For this application, ESP Plus selected a standard four pole motor. The weight of the pump is given; an important fact in constructing an adequate foundation. The NPSHR is only 7.48 feet, probably easy to meet in this closed loop, pressurized system. The 9.25" impeller will be 83.77% efficient, using only 28.93 hp at the duty point. ESP Plus has recommended using a 30 hp motor since that choice was made back in the initial screen. Notice that this impeller will use 32.27 hp if it were to run out to maximum flow. Under these conditions, the 30 hp motor would be operating in its service factor, or, if it had a service factor of 1.0, it would overload the motor and trip out on overload. In order to avoid this problem, another choice could be made on the initial screen. If "Use Non-Overloading Motor" had been selected, then ESP Plus would have chosen a more expensive 40 hp motor, the next larger size. A third alternative exists on the initial screen; "ESP Optimized™ Motor Selection". This aids the designer in choosing a motor size that's large enough to serve whatever portion of the pump curve is important without paying for a motor that is large enough to serve the entire curve. The minimum recommended flow of 270 gpm is provided to aid in the design of minimum flow protection bypass piping.

The cost analysis on the right shows that this pump operating at the design point all year long, at \$0.10/KWH will cost almost \$20,000.00! That energy cost is probably much greater than the total installed cost of the pump. This illustrates the value of a life cycle approach to pump selection, for the energy cost difference between two pumps is probably far more important than small differences in initial cost. But it's unlikely that this pump will actually operate at the design point all year long. This is where the load profile and cost analysis sections of ESP Plus can help the designer make better decisions.

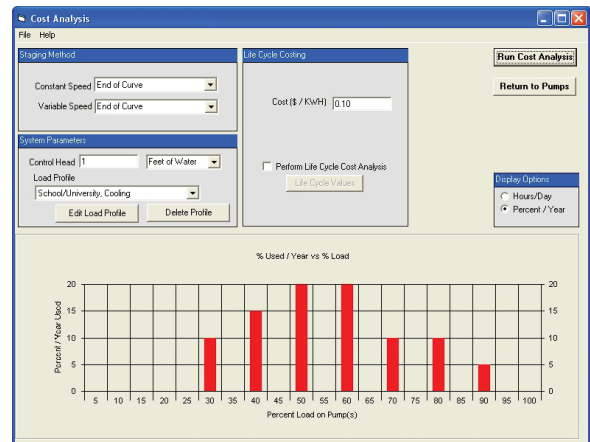

**ESP Plus Cost Analysis**  
**Figure 57**

The cost of electricity and the load profile for a university chilled water system have been chosen. The profile shows the typical pattern of usage for such a system in terms of percent of usage. The two-way valves in the system will reduce flow during the part load periods, reducing energy costs.



ESP HTML Viewer

Close Print

### Constant Speed System Analysis

Staging Method: END-OF-CURVE

Motor Size: 30HP  
Service Factor: 1.15  
Manufacturer: US Prem Eff  
Catalog: J268

Load	Hours	Flow GPM	Head Feet	Pump Eff.	BHP	Motor Eff.	kWHR	Cost/day	Wire/Water Eff.
30%	2.40	350.0	94.52	47.34	18.17	94.73	34.33	\$3.43	44.85%
40%	3.60	480.0	94.13	56.40	20.23	94.74	57.32	\$5.73	53.44%
50%	4.80	600.0	93.20	64.27	21.97	94.72	83.03	\$8.30	60.88%
60%	4.80	720.0	91.85	70.94	23.54	94.66	89.01	\$8.90	67.15%
70%	2.40	840.0	90.05	76.42	25.00	94.58	47.30	\$4.73	72.28%
80%	2.40	960.0	87.84	80.71	26.39	94.48	49.98	\$5.00	76.25%
90%	1.20	1,080.0	84.89	83.39	27.76	94.35	26.33	\$2.63	78.68%

Constant Speed Operating Cost

Total Kilowatt Hours = 141,300 Cost per kw/hr = \$0.10

Total Hours per Year = 8,760 Annual Operating Cost = \$14,130

**ESP Plus Cost Analysis for Constant Speed**  
**Figure 58**

The load profile is shown in the first two columns as a percentage of full flow versus hours for a theoretical 24 hour day that experienced the entire load profile. Note that the system valves reduce flow in satisfying the load demand, riding up the pump curve as shown in columns three and four. The pump efficiency falls as the point of operation shifts to the left, but the BHP being used falls during the part load hours. Motor efficiency remains high throughout the profile. At the default value for electrical cost, a better estimate of the energy costs is about \$14,000.

Variable speed pumping tends to reduce energy costs significantly, assuming it's properly designed and installed. ESP Plus can model costs for variable speed too.

**Summary**

Pump selection is a little like gambling with someone else's money. The designer is promising that he/she can obtain a decent return on an initial investment of the customer's money. The return is in terms of an initial investment representing the installed cost of the pump versus a time value series of future costs and benefits obtained by the pump for the building owner. The ESP Plus application is very good in aiding the designer in making better selections. It provides a great deal of important information needed to make a good selection and insure that it gets installed properly, but it has important limitations. The system analysis that defines required head and flow must be done carefully; the cost analysis is not useful for energy budgeting-it does not include important factors like demand charges. Still, a careful, knowledgeable designer can use tools like ESP Plus and System Syzer® to make better decisions in less time on behalf of his or her customers.

ESP HTML Viewer

Close Print

Load	Hours	Flow GPM	Head Feet	RPM	Pump Eff.	BHP	Drive/Motor Eff.	kWHR	Cost/day	Wire/Water Eff.
30%	2.40	300.0	8.1	558	83.93	0.88	85.23	1.84	\$0.18	71.5%
40%	3.60	480.0	13.6	727	83.97	1.97	88.21	5.99	\$0.60	74.1%
50%	4.80	600.0	20.8	899	83.98	3.75	88.30	15.18	\$1.52	74.1%
60%	4.80	720.0	29.4	1073	83.94	6.38	88.18	25.89	\$2.59	74.0%
70%	2.40	840.0	39.7	1247	83.93	10.04	87.74	20.48	\$2.05	73.6%
80%	2.40	960.0	51.6	1422	83.92	14.90	87.30	30.54	\$3.05	73.3%
90%	1.20	1,080.0	65.0	1598	83.91	21.13	86.85	21.77	\$2.18	72.9%

Variable Speed Operating Cost

Total Kilowatt Hours = 44,417.2 Cost per kw/hr = \$0.10

Total Hours per Year = 8,760 Annual Operating Cost = \$4,441.72

**ESP Plus Cost Analysis for Variable Speed**  
**Figure 59**

For this pump and load profile, variable speed can reduce energy costs to about \$4400.00 per year.

## NOTES



# Xylem |'zīləm|

- 1) The tissue in plants that brings water upward from the roots;
- 2) a leading global water technology company.

We're 12,500 people unified in a common purpose: creating innovative solutions to meet our world's water needs. Developing new technologies that will improve the way water is used, conserved, and re-used in the future is central to our work. We move, treat, analyze, and return water to the environment, and we help people use water efficiently, in their homes, buildings, factories and farms. In more than 150 countries, we have strong, long-standing relationships with customers who know us for our powerful combination of leading product brands and applications expertise, backed by a legacy of innovation.

**For more information on how Xylem can help you, go to [www.xylem.com](http://www.xylem.com)**



Xylem Inc.  
8200 N. Austin Avenue  
Morton Grove, Illinois 60053  
Phone: (847) 966-3700  
Fax: (847) 965-8379  
[www.xylem.com/brands/bellgossett](http://www.xylem.com/brands/bellgossett)

Bell & Gossett is a trademark of Xylem Inc. or one of its subsidiaries.  
© 2012 Xylem Inc. TEH-1208A October 2012