

# Hydronic System Design with the Bell & Gossett® System Syzer®

## TABLE OF CONTENTS

Introduction.....	1
Determining required flow rate .....	1
System pressure drop .....	2
Velocity and friction head loss limits.....	2
System piping arrangements .....	2
Design example: Series Loop System .....	2
Design example: Two-Pipe System.....	3
Application of pump curve data .....	4
Specific gravity.....	4
Waterhorsepower.....	4
Effect of volume flow changes .....	5
Calculating system pressure drop .....	5
Piping pressure drop .....	5
Fitting and valve pressure drop .....	5
Pressure drop of other system components .....	6
Control valve pressure drop: control valve types .....	6
Procedures for calculating circuit pressure drop .....	8
The design process: Example: Two circuit series loop .....	8
Pump selection using the system curve .....	9
The Bell & Gossett System Syzer® .....	10
Scale 1: Load, flow and delta T relationship .....	10
Scale 2: Flow, head loss, and pipe size relationship.....	11
Scale 3: Flow velocity .....	12
Scale 4: Circuit pressure drop .....	12
Scale 5: Determining unknown pressure drops, system curves, and control valve Cv.....	13
Design example: Pumps in parallel using the System Syzer .....	13
Design example: Three zone, two pipe system .....	14
Pump selection using Bell & Gossett ESP PLUS .....	18
System design using ESP PLUS System Syzer® .....	21
Advanced circuit analysis.....	22
Circuit flow coefficient.....	22
Equivalent Cv of components in series .....	22
Control valve authority.....	22
Equivalent Cv of components in parallel .....	23
Appendix .....	25

### NOTE:

Pump curves and other product data in this bulletin are for illustration only. See Bell & Gossett product literature for more detailed, up to date information. Other training publications as well as the Bell & Gossett design tools described in this booklet including the System Syzer, analog and digital versions, and ESP Plus are all available from your local Bell & Gossett representative. Visit [www.bellgossett.com](http://www.bellgossett.com) for more information or contact your Bell & Gossett representative.

## Introduction

Hydronic heating or cooling systems use water as the means for carrying heat from one point to another. They are becoming more complex as they grow in capacity, and as control methods become more sophisticated. Small systems may still use a single pump, but it now serves several different temperature zones: low temperature radiant systems, higher temperature supplemental heat or domestic water zones. Large systems may use pumps in parallel, serving many buildings. Flow may be controlled by automatic temperature control valves and variable speed drives to reduce the amount of energy used by the pump. As a result, pressures and flows are constantly changing to meet the current need for heat transfer.

All of these improvements and refinements depend upon the design of the pumping and piping system. It is still vitally important to design the piping system, size the piping, and determine the actual system pressure drop in order to select a pump for lowest overall life-cycle cost, and take full advantage of modern energy saving techniques.

### Determining the flow rate

Flow in a hydronic system is used to carry heat, so an accurate heat load calculation is the foundation for any system design. The following formula is often used to determine required flow in hydronic systems:

$$GPM = \frac{\text{Heat Load}}{500 \Delta t}$$

Where:

gpm is the volume flow rate, gallons/minute

Heat load is in BTU/Hr, or BTUH

$\Delta t$  = Temperature difference between supply and return, °F

500 is the constant for standard water properties at 60 °F;

Density, 8.33 lbs. per gal.

Specific heat, 1 BTU/lb °F

The complete calculation is then:

$$GPM = \frac{\frac{BTU}{hr}}{8.33 \frac{lb.}{gal} \times 1 \frac{BTU}{lb \cdot ^\circ F} \times 60 \frac{min}{hr} \times \Delta t ^\circ F}$$

Where  $8.33 \times 60 \times 1 \approx 500$

Both the specific heat and density in the formula are referenced to 60°F water. Since 60°F water is too cool for typical heating systems and too warm for typical cooling systems, it may seem that flow should be calculated by taking into account the following changes:

1. Specific heat and density changes caused by water temperature changes.
2. Volume flow changes between supply and return pipes due to temperature differences between them.

Mr. Gil Carlson, the Director of Technical Services for Bell & Gossett, discussed these issues in an article published in HPAC Magazine in February, 1968 entitled "How to Save Pumping Power in Hydronic System Design". His basic analysis was updated and extended for this book.

We can evaluate the effect of these changes in physical properties on heat conveyance of water by determining the net change in heat conveyance as system temperature rises.

The formula for determining system flow rate assumes a mass flow rate of 500 lbs. per hour for each gpm which means that at a 20°  $\Delta t$ , 1 gpm will convey 10,000 BTUH (500 x 20) referenced to 60° water. Now determine what happens to the heat conveyance of 1 gpm @ 20°  $\Delta t$  when the circulated water has a system average temperature of 200°, (supply temperature = 210 and return temperature = 190). Water at 200° has a density of 8.04 lb/gallon instead of 8.33 as at 60°, however, the specific heat goes up to 1.003 from 1.0 as at 60°. The heat conveyance for 1 gpm at 20°  $\Delta t$  will then be:

$$8.04 \times 60 \times 1.003 \times 20 = 9,677 \text{ BTUH}$$

The net effect is therefore not significant in itself, but there is another factor to be considered for a complete evaluation. As water temperature rises, it becomes less viscous, and therefore its pressure drop is reduced. At 200°, water pressure drop, or "head loss", is about 81% of water at 60° for typical small hydronic systems. Figure 1 gives a graphical analysis of the effect on system flow. The "system curve" represents the changes in system head loss as system flow changes for any fixed piping system. It will be described more completely later.

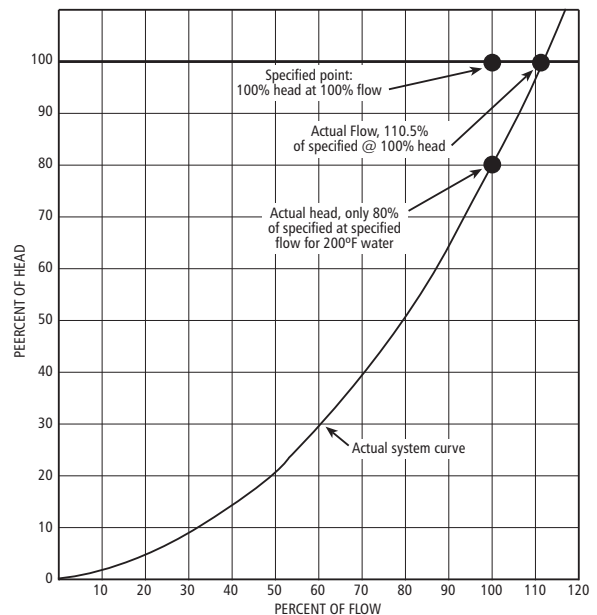

Flow increase resulting from operation at 200°F rather than at 60°F base amounts to 10.5 percent.

**Figure 1**

Note that the flow increase amounts to 10.5% in this case. Multiply the heat conveyance just calculated by the percentage of flow increase:

$$1.105 \times 9,677 = 10,693 \text{ BTUH}$$

It is apparent that from the standpoint of heat conveyance, the simple "round number" approach will result in design flows very close to the "temperature corrected" flows, providing the result from the "round number" approach is left uncorrected from the original 60°F. base for both heat conveyance and piping pressure drop. The plus and minus factors very closely

offset one another. A similar analysis for chilled water systems shows that increased viscosity at lower temperatures reduces flow compared to 60°F water, but the changes are small. Sometimes other fluids are used to carry heat; for example, water and glycol solutions. Their properties are likely to be quite different from those of standard water, so the system designer must account for them. The tools for doing that will be described later.

### System Pressure Drop

Water flowing through piping encounters resistance due to friction at the confining walls of the piping. This resistance is called the "pressure drop", or "friction head loss" of the piping system. Pumps are installed in a closed loop piping system in order to apply work to the system fluid to overcome friction head loss and maintain flow.

Pressure drop will, of course, vary with the condition of the piping; the rougher or more corroded or scaled the piping, the higher the pressure drop for a given pipe length and flow. Pressure drop tables are available for new, clean pipe as well as for piping which has aged and offers more resistance to flow because of its relatively poor condition.

Piping in a closed system, with little or no make-up water, can be considered to be clean pipe since it does not deteriorate or scale with the passing years. Use of aged pipe pressure drops will result in deceptively high calculated pressure drops which in turn result in the selection of pumps which are oversized for the system. The oversized pump will cause flows much greater than design requirements resulting in high water velocities which in many cases become audible and result in unhappy building tenants. On the other hand, piping in open systems like cooling towers can experience aging. Higher design velocity in these piping systems may retard scale deposits. Any noise is unlikely to cause objections, although the resulting higher pressure drops will increase pumping costs.

### Velocity and Friction Head Loss Limits

The selection of pipe sizes and pumping equipment also involves economic factors. Pumps which are larger than necessary result in higher initial costs and increased operating costs, especially in larger horsepower ranges.

Pipe size is determined by the flow rate required in that portion of the system. The designer must give due consideration to the effect of the pipe size on water velocity and pressure drop. The water velocity should, of course, be evaluated on the basis of both the lowest and highest velocities which can be tolerated. Velocities must be high enough to entrain any air and carry it to the air separator but low enough to avoid the generation of flow noise.

Tests have shown that minimum velocities of 1½ to 2 feet per second must be maintained to entrain air bubbles; particularly to drive them down vertical piping. Selecting a pipe with a friction loss rate of 0.85 feet of head loss per 100 feet of length will insure adequate minimum velocity. The maximum allowable velocity depends on pipe size. Small diameter pipes up to 1½" can allow velocities up to 4 feet per second. Higher velocities can be allowed in larger pipe sizes.

Where quiet operation is a design objective, sizing piping for friction loss rate no greater than 4.5 feet of head loss per 100 feet of length will give good results.

Where noise is not an important consideration, higher velocities may be used within the limits imposed by economical pump selection. A prime consideration in any case is entrained air, which can cause noise even at low water velocities. System design for proper management of entrained air can be accomplished as outlined in other Bell & Gossett publications.

### System Piping Arrangements

Prior to the determination of actual pipe size and pressure drop determination, the designer must establish the piping configuration of the proposed system to deliver water to the heat transfer units. Single pipe and two-pipe systems of various kinds are available. Each has characteristics which may make it more or less appropriate for the system being designed. The flow required to carry heat to or from each terminal unit, and the pipe size to carry this flow can be determined next. The pressure drop can then be calculated for the various pipe sizes and lengths in the circuit using tools provided for this purpose. In addition to the piping, the circuit will contain fittings, heat transfer equipment, valves of various types and the terminal units themselves; these will also offer resistance to flow so their pressure drops must be calculated or estimated and added to that of the piping.

### Design Example: Series Loop Piping System

The simplest distribution piping arrangement is the series loop, used primarily for residential, small apartment systems and retrofits. In this system, the radiation is connected in series and therefore, becomes a part of the piping main. The basic advantage is economy as substantial savings in piping materials and the cost of installing these materials are affected. Figure 2 illustrates a one-pipe series loop system.

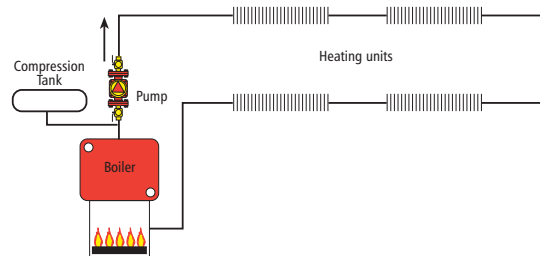

Series Loop System  
Figure 2

Water temperature entering each unit depends upon how much heat was extracted or added upstream. This makes it impractical to install too many units in series since the water temperature could become too high or too low for effective heat transfer. The flow through a single circuit system is limited to the water carrying capacity of the tube size used in the heating units. In residential systems, these units are often ¾" copper baseboard, but commercial systems may use 1" or 1½" units. They may also use much higher pressure drop units like convectors or unit heaters. Another limit to circuit

length is the combined pressure drop of all the components. Too many components in series would require very high pump head. Control of heat transfer by modifying the flow is limited since a reduction at one device reduces flow through all of the terminals in that circuit.

When the system flow requirements exceed the capacity of a single circuit, two or more circuits may be taken off a distribution or "trunk" main. A return trunk main is used to pick up the various circuits and return them to the boiler.

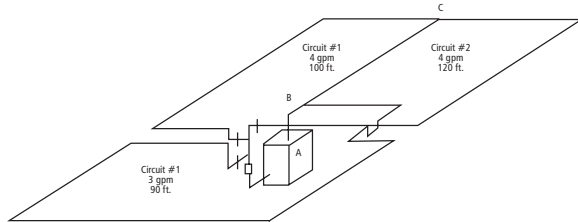

**Three Circuit Series Loop System  
Figure 3**

This is a three circuit series loop system. Assuming the use of 3/4" copper tube convector baseboard, each circuit must be limited to the flow this size tube can handle within practical limits of pressure drop and velocity; about 4 gpm. The minimum flow rate and supply temperature leaving the boiler must be great enough to supply all three zones simultaneously. At a 20° Δt, that means:

- Circuit #1 is getting 40,000 BTUH
- Circuit #2 is getting 40,000 BTUH
- Circuit #3 is getting 30,000 BTUH

The supply trunk, A-B, must carry 11 gpm, section B-C must carry 8 gpm, and so on.

The system pressure drop is determined by that of the highest pressure drop circuit. Circuit #2 is the longest as measured from the boiler supply, through the circuit and back to the boiler return. A pump must be able to provide the sum of all three circuit flow rates, 11 gpm at the head determined by the longest, or highest pressure drop circuit.

### Design Example: Two-Pipe Systems

In a two-pipe system, the heat transfer terminals are in parallel. The difference in pressure from the supply main at the pump discharge to the return main at the pump suction allows the use of higher pressure drop coils. All of the devices see the same supply temperature, and "zoning", is easy and

effective since the flow through one circuit can be changed without a substantial effect on the other zones. A "zone" is a room or a collection of rooms which are sufficiently similar in terms of heat transfer requirements that they could be controlled by a single control device, e.g., a thermostat. In an apartment building, each apartment will probably be a separate zone. Larger, multiple zone systems, will benefit in piping cost savings from a careful analysis of pressure drop. Figure 4 shows a two-pipe, direct return system on the left. The first circuit to get water is the first to return it. Since the farthest unit has the longest pipe run, it probably determines the pump head required, assuming that all the terminals have roughly equal pressure drop. A reverse return system, shown on the right will equalize the piping length, so all terminals see the same pressure difference from supply to return.

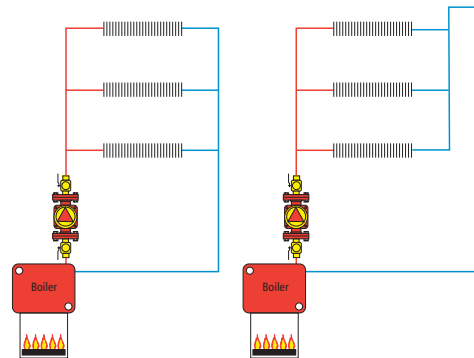

**Direct Return and Reverse Return Two-Pipe  
Pumping Systems  
Figure 4**

Figure 5 is a piping layout for a 12-apartment, zone controlled heating system. The system layout is based on overhead supply, with four supply risers dropping down from the supply main. Each supply riser feeds three apartments, with series loop connected baseboard controlled by a zone valve in each apartment. Return risers drop down from each group of three apartments and are picked up by the basement return main. Both the mains and the risers are hooked up in reverse return. Apartments are all the same size; the four top apartments each have a heat loss of 40,000 BTUH while the other apartments are 34,000 BTUH each.



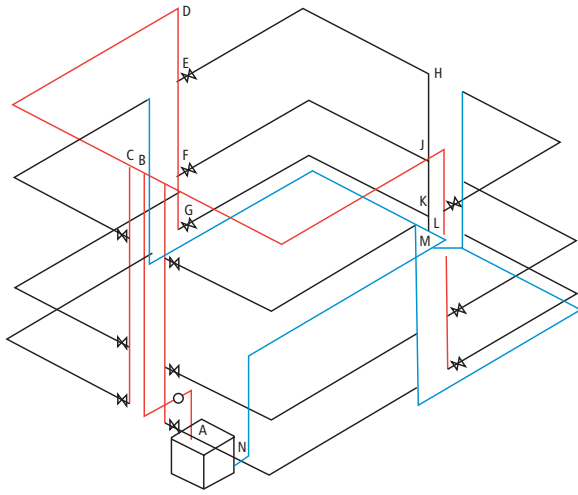

**Figure 5**

Figure 6 shows only the top floor circuit which will be used to determine the system pressure drop, and therefore, the pump head requirement. The flow in each pipe section is shown and the lengths are determined from the plan.

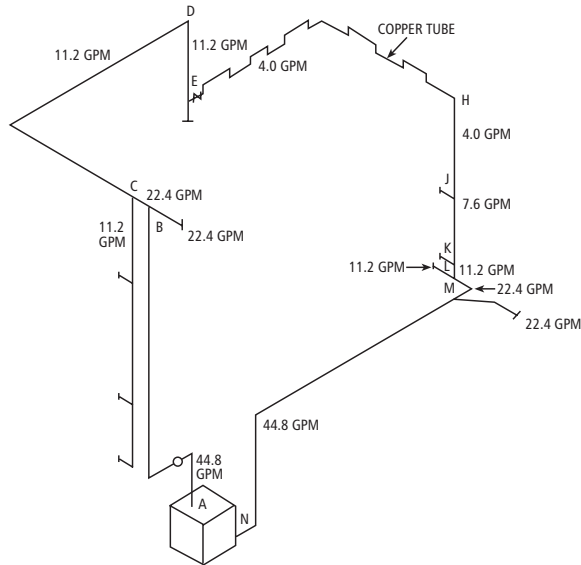

**Figure 6**

The trunk main, A to B, is sized to carry full system flow, but flow in the supply main becomes smaller as each radiation zone gets its share of the flow, while the flow in the return main gets larger. An experienced designer would probably select a 2½" or possibly a 2" pipe for section A-B. The smaller pipe would have the greater friction loss rate over the length of A to B. The product of length and friction rate yields the total head loss in that pipe. Section B-C carries 22.4 gpm but is very short. Section C-D carries only 11.2 gpm but is much longer, and contains more fittings. Theoretically, each section of pipe must be evaluated in terms of the flow it must carry, a pipe size must be chosen, friction loss rate determined, then multiplied by length to get the total head loss in that section. After that, the sum of head loss in all sections has to be added to the head loss of the boiler and the fittings before the pump

can be selected. In practice, the process can be simplified by applying some judgment. For example, an average flow rate, or most important flow rate could be applied to a long pipe section to reduce the number of calculations, rules of thumb might be applied to account for fittings, etc. Later in this book, we'll see that the Bell & Gossett System Syzer® is invaluable in this process.

## Application of Pump Curve Data

Centrifugal pump performance curves are developed by test with 85°F water and usually relate flow in gpm to foot head.

In terms of relating pumping capacity, the term "foot head" indicates that the pump is applying one foot-pound of energy to each pound of liquid being pumped. The curve can be used for water at any temperature, since "foot pounds per pound" is an energy statement based on a specific weight to energy relationship that remains the same regardless of temperature or fluid density.

## Specific Gravity

Standard water, with a specific gravity of 1.0 supports a water column of 2.3 ft. for each PSI, or 0.43 psi per foot of water column. The fluid column required for any other specific gravity is derived by the formula:

$$\text{Fluid column in feet} = \frac{2.3}{SG}$$

For a fluid of lower density, specific gravity of 0.6:  
 Fluid column in feet = 2.3/0.6  
 = 3.85 feet

## Water Horsepower

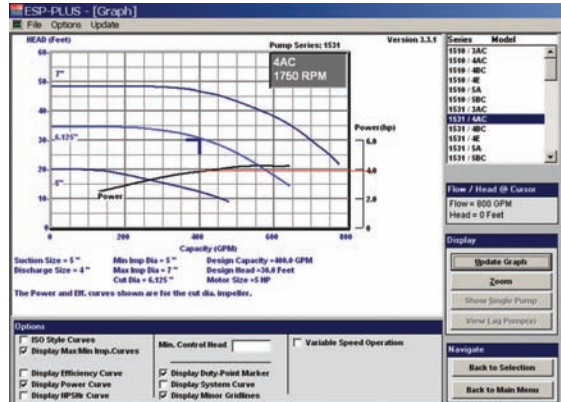

**Bell & Gossett Series 1531 Pump Curve  
Figure 7**

A pump curve indicates the pump will deliver 400 gpm at 30 ft. head. This means the pump will add 30 ft-lbs energy to every pound of liquid when 400 gpm are circulating. If the liquid is water at 8.3 lbs/gal, the weight of the circulated water would be 3,320 lb /min. At 30 ft-lb per lb this would be 30 x 3,320 or 99,600 ft-lb/min energy input to the pumped water. Dividing by 33,000 ft-lb/min per HP indicates the pump is applying about three water horsepower, "WHP".

$$\text{WHP} = \frac{\text{Head, } \frac{\text{ft-lb}}{\text{lb}} \times \text{Flow, } \frac{\text{gal}}{\text{min}} \times \text{Specific gravity}}{33,000 \frac{\text{ft-lb}}{\text{min}} \times \frac{1 \text{ gal}}{8.34 \text{ lb}} \times \text{hp}}$$

$$\text{WHP} = \frac{\text{Head (ft)} \times \text{Flow (gpm)} \times \text{SG}}{3960}$$

$$\text{WHP} = \frac{30 \times 400 \times 1}{3960}$$

$$\text{WHP} = 3.03 \text{ hp}$$

The WHP used by a pump is very important because it relates the system head and flow to the pump's power requirement. WHP represents the "transport energy" required to move water against the system's resistance. No practical machine can be 100% efficient, so the actual horsepower input to the pump will always be greater than the WHP. The efficiency of the pump and the WHP combine to determine the actual amount of power required by the pump in the given system. This factor is called brake horsepower, or "BHP". If the pump is 80% efficient at 400 gpm and 30 feet of head, it would use a little less than 4 hp.

$$\text{BHP} = \frac{\text{BHP}}{\text{Pump efficiency}}$$

$$\text{BHP} = \frac{30 \times 400 \times 1}{3960 \times .08}$$

$$\text{BHP} = 3.79 \text{ HP}$$

Since 4 HP motors are not standard, this power would probably be provided by a motor rated to provide 5 HP, but actually delivering only 3.79 HP to the pump. These values are displayed in Figure 7, which is a screen taken from Bell & Gossett's ESP Plus. This useful computer application will be described in more detail later. The electrical energy used by the pump, and therefore the building owner's cost to operate that pump, make BHP a very important factor in selecting and evaluating pump performance.

Assuming that gauges were placed on the suction and discharge openings of the pump and that these gauges were calibrated in PSI, what would the differential readings be? Since we have added 30 ft-lbs of energy per pound, each pound is equivalent to 30 feet of the pumped liquid. In this case, water is being pumped with a weight of 0.43 PSI per ft., so the gauges would read a differential of 30 ft. x 0.43 PSI or 12.9 PSI differential.

The specific gravity of the pumped fluid affects the required water horsepower to raise the energy level of the pumped fluid. Suppose the fluid being pumped had a specific gravity of 0.6, or 0.6 times the density of standard water. This fluid would have a weight of 0.26 psi per ft. The gauge differential would be 30 ft. x .26 or 7.8 PSI.

Thus, the gauge differential, regardless of specific gravity, will always read the energy level in terms of feet of the fluid being pumped. In the case of the gauge differential with water, the head can be determined by using the differential of 12.9 PSI and multiplying this by 2.31 feet per PSI, which gives 30 feet of head. Reference to the pump curve would indicate a flow of 400 gpm.

The fluid with a specific gravity of 0.6 would require a column 3.85 ft. high to exert a pressure of 1 PSI. The gauge reading differential for this fluid was 7.8 PSI; multiplying by 3.85 ft. per PSI gives 30 ft. as the pump head.

Therefore the pump curve can be applied to liquids of any specific gravity without correction. The changes in specific gravity of water due to temperature have no effect on the pump curve. Even though these curves are established by test with 85° water, they may be used for water of any temperature.

### Effect of Volume Flow Changes

Water expands when it's heated, contracts when it cools, so volume flow, in ft<sup>3</sup>/min changes a little bit due to temperature differences. Warmer water in the supply will flow a little bit faster than the return water. These differences are small enough to ignore without introducing any appreciable error. But the mass flow rate, lb/min remains a constant because water is essentially incompressible. At steady state conditions, that is, the average water temperature in the system is not changing; the mass flow rate must be the same in the supply and return mains regardless of the difference in temperature between them. In other words, the heat input at one point in the system must be equal to the heat rejected at some other point.

## Calculating system pressure drop

### Piping Pressure Drop

Pressure drop in straight runs of piping could be calculated by reference to charts which state these losses in terms of feet of 60 °F water head per hundred feet of piping. An example is included in the appendix.

The Darcy-Weisbach relationship is the basis for determining friction head loss in pipes:

$$\text{Friction head loss} = f \left( \frac{L}{D} \right) \left( \frac{V^2}{2g} \right)$$

Where:

Friction head loss is in units of feet of head, or foot-pounds of work lost to friction/pound of fluid

*f* is the friction factor, which relates variables such as Reynolds number, relative roughness of the pipe, and flow regime, e.g. laminar, transition, or turbulent flow.

*L* is the pipe length in feet

*D* is the pipe diameter in feet

*V* is the average flow velocity in the pipe in feet per second

*g* is the gravitational constant, 32.2 feet per second<sup>2</sup>

The rate of friction head loss used to be stated in terms of "milinches" per foot of pipe. A milinch is 1/1000 of an inch; therefore, one foot of head is equivalent to 12,000 milinches. This term was used because it was convenient to work with when dealing with small increments of head loss. Most designers today use units of feet of head loss per 100 feet of system length. Design flow rate, pipe size, and pipe type will determine the friction loss rate.

### Fitting and Valve Pressure Drop

Pressure drop for various fittings and standard valves is sometimes stated as some multiple of the velocity head:

$$\text{Fitting head loss} = k \times \frac{V^2}{2g}$$

Where

k is the head loss coefficient for the type of fitting

V is the average velocity of flow through the fitting

g is the gravitational constant

It is possible to save time-consuming calculations for determining fitting pressure drops by establishing a table which reads directly in equivalent feet of piping for all fittings. The variation in equivalent length due to velocity differences is not of great magnitude in the flow ranges encountered in hydronic design work. A table of fitting equivalent length is included in the appendix. In determining the length of pipe and the pipe size attributable to a given fitting, the downstream pipe size is used and the fitting pressure drop is established as the number of feet of that pipe size multiplied by the friction loss rate. Figure 8 illustrates how the pipe size is determined. For example, if the flow pattern is from C to B, the pipe size of F would be used in assigning pressure drop for the branch flow of the tee.

Where flow enters a tee at C and splits to both A and B, the pressure drop of the circuit flowing from C to B would involve the tee branch loss based on pipe size F. The circuit flowing from C to A would include the tee branch loss based on pipe size J.

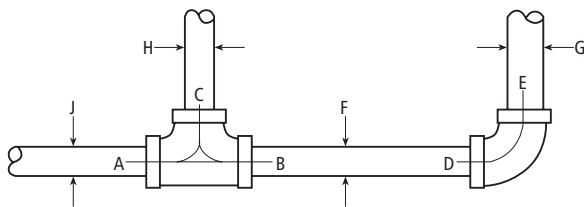

Flow Path	Pipe Size Applying to Equivalent Length
A to B	F
A to C	H
C to B	F
D to E	G

Figure 8

### Pressure Drop of Other System Components

A piping circuit has, in addition to the pipe and fittings, components such as heat exchangers, boilers, or other units which have a substantial pressure drop. The pressure drop of these components is usually stated by the component manufacturer in either tabular form at various flow conditions or as pressure drop curves on a chart. Figure 10 is such a chart showing the pressure drop characteristics for Bell & Gossett Circuit Setter Balancing Valves. Circuit Setters are used to prevent unwanted excess flow in the branch of the system where it's installed. The round dial sets, and indicates the valve opening.

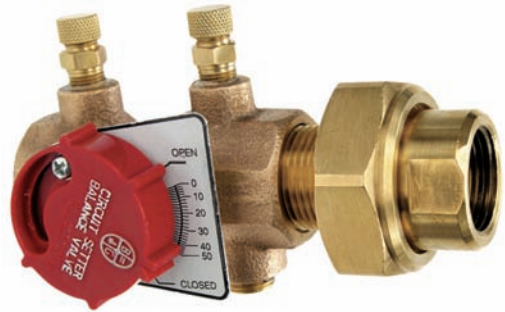

Bell & Gossett Circuit Setter  
Figure 9

As an example of the use of this chart, assume that a circuit branch has a Circuit Setter Valve in it set at "0". The valve presents little resistance to flow, so a given pressure difference on the vertical axis results in a large flow rate represented on the horizontal axis by gpm 1. As the valve is set more nearly closed, the flow rate at the given differential pressure would be reduced shown as gpm 2 and then gpm 3. All components in the system: pipes, elbows, heat exchangers, demonstrate a similar relationship between flow rate and head loss or pressure drop. The Circuit Setter is unlike those other components in that it can change the relationship as it is manually set from wide open to dead shut.

### Control Valve Pressure Drop

Pressure drop data for control valves is often given in terms of a "Cv" rating for the valve. The Cv for any given valve is the flow in gallons per minute that would cause a 1 psi pressure drop to appear across the valve. For example, a valve with a Cv rating of 10 would have 1 psi pressure drop when 10 gpm flow occurred through the valve.

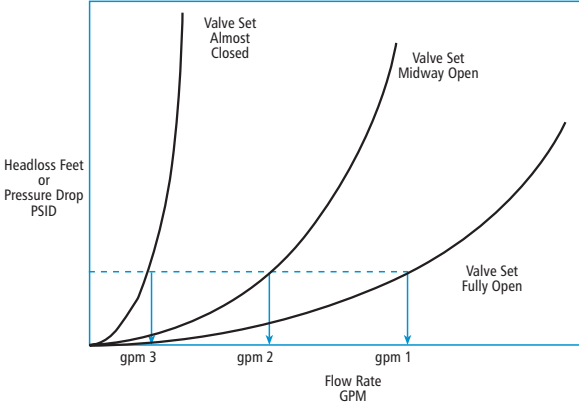

Flow Rate vs Pressure Drop  
Figure 10

In the Circuit Setter, each manual dial setting establishes a unique Cv. If the horizontal dashed line represents 1 psi or 2.31 feet of head loss for standard water, then gpm 1 is the Cv for the fully open Circuit Setter, gpm 2 and gpm 3 are the lower Cv's as the valve is closed. If the valve is shut dead tight, the Cv is 0.

System control valves react in exactly this way, but they operate automatically in response to a thermostat and temperature control system.



The pressure drop of the valve will vary as the square of the flow difference. Since the valve pressure drop is 1 PSI at its Cv flow rating, the formula is:

$$C_v = \frac{\text{GPM}}{\sqrt{\Delta p}}$$

The flow and pressure drop relationship can be established for any condition using the Cv.

To illustrate, assume a valve with a Cv of 10 will be used to control a flow of 30 gpm, what will the pressure drop through the valve be at this flow?

$$\text{Valve pressure drop (psi)} = \left[ \frac{\text{GPM}}{C_v} \right]^2$$

$$\text{Valve pressure drop (psi)} = (30/10)^2$$

$$= 9 \text{ psi}$$

To determine the pressure drop in terms of feet of water head, multiply by 2.3 assuming standard water.

$$9 \times 2.3 = 20.7 \text{ Ft.}$$

### Control Valve Types

Control valves are used to modulate the system water temperature or to control the quantity of water flowing through the system heat exchangers. The valves are furnished in two general types, two-way or three-way, depending on the number of ports in the valve.

Two-way valves are often used as two-position valves, either open or closed. A commonly used illustration is the zone valve, operated by a thermostat, which opens the valve on a call for heat and closes it when the heat demand is satisfied.

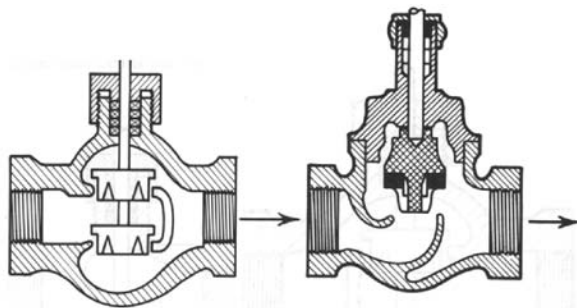

**Double and Single Seated Control Valves**  
Figure 11

The double-seated valve has no hydraulic forces acting on the valve stem, as water flowing through the ports tends to open one disc and close the other. The single-seated valve must operate against the hydraulic force of the water entering the port as the valve moves toward the closed position. The double-seated valve is not used for tight shut-off requirements as the common shaft connecting the two discs expands and contracts with temperature changes, making it difficult to close both ports simultaneously. Therefore, either valve may be used for modulating type operation but for two-position, (on-off) the single-seated valve is used.

For two-position operation, the valves are usually line-sized and are selected for low pressure drop. Modulating valves, on the other hand, should be selected for high initial (wide open) pressure drops as this enhances control operation by keeping the pressure drop increase ratio at a minimum as the

valve modulates to close-off. The topic of "valve authority" is discussed later in this book. Other Bell & Gossett publications explain valve selection in detail.

Three-way valves are furnished in two basic types. The mixing type has two inlet ports and the third, or common port is the outlet. The diverting type makes the common port the inlet and the other two ports are outlets as shown in Figure 12.

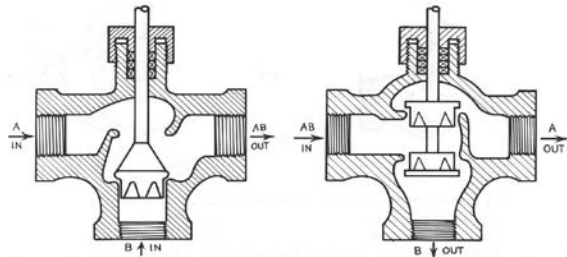

**Three-Way Mixing and Diverting Valves**  
Figure 12

Severe valve chatter may result if the common port of a mixing valve is used as an inlet with the other two ports as outlets as in a diverting valve. As the valve disc approaches either seat, the velocity pressure will tend to over-ride the operator and slam the valve shut. The velocity pressure is now gone and the valve motor will then open the valve again. This occurs rapidly, with severe chattering as a result.

The same thing happens with a diverting valve if an attempt is made to use it as a mixing valve. This would require the A and the B ports to be inlets, with the AB port as the outlet. The velocity pressure would act to over-ride the operator as either disc approached its port, resulting in valve slam or chatter.

The application and sizing of three-way valves is covered in other Bell & Gossett publications. A general statement on valve selection can be made without going into the actual procedures. Three-way valves applied in the equipment room for temperature modulation or system change from heating to cooling should be selected for low pressure drops, if possible under ten feet, in order to minimize required pump head.

It is important from the standpoint of flow stability in a system using three-way valves to control coil flow, to select the valves for a substantial portion of the available pump head. As in two-way valves used for this purpose, the pressure drop across the valve increases as the valve closes down. This causes an increase in flow through the valve, making it necessary to close off still further to compensate for the increase in flow. If the valve is selected for a low pressure drop, the pressure drop ratio necessary to throttle to a given flow will be very large and the valve will have to "ride" its seat to achieve control.

Therefore, it is good practice to select the valve for high initial pressure drops, on the order of three times the coil pressure drop at design flow, if possible. Due to the fall off of coil pressure drop with reduced flow, coils used with three-way valve control should be selected for low design pressure drop. This decreases the effect on circuit pressure drop as the control valve goes to bypass. Typical three-way valve and coil installations are shown in Figure 13. The bypass pipe around the coil must have a Circuit Setter in order to equalize the

resistance of the paths through the coil and bypass. Without the Circuit Setter, the pump flow would increase whenever flow shifted to the bypass.

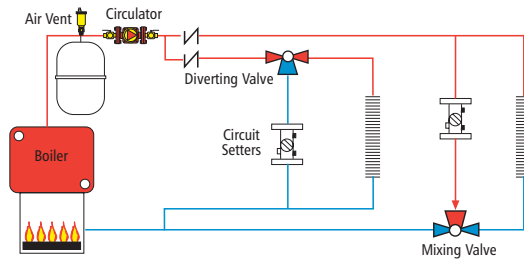

**Circuit Setters in Diverting and Mixing Valve Applications**  
**Figure 13**

**Procedures for Calculating Circuit Pressure Drop**

Total Equivalent Length Method for Fitting Pressure Drop. Calculating the actual pressure drop for each fitting can be a time-consuming and therefore, expensive procedure. In an effort to reduce design time, an alternate method was devised in which it is assumed that the fittings and other system components are equal to 50% of the circuit length. This 50% is added to the circuit length and the total is considered to be the Total Equivalent Length, TEL, of the circuit. Practical experience has shown that this method leads to sufficiently accurate results for systems up to about 400,000 BTUH. Larger systems would warrant a more detailed analysis since savings in pipe size or pumps may result. Short circuits with more than the average member of fittings should also be carefully evaluated, since the 50% allowance may not be sufficient to cover the actual fitting losses. Simple logic and experience will indicate when a pipe sizing check using actual pressure drop data for each fitting is required.

Keep in mind that the "50% method" is for fittings and conventional baseboard radiation only. In the event that there are high pressure drop devices such as fan coil units in the circuit, the pressure drop of these devices should be considered separately.

When the system consists of a single circuit, the pump must provide the needed flow and overcome the piping pressure drop at this flow. Larger systems require more circuits to keep the pressure drop and pipe size down. The pump on multi-circuit systems must be capable of meeting the pressure drop of the highest pressure drop circuit, which is usually the longest circuit. The pump also must furnish the flow required by all circuits.

The circuits with lower pressure drops will tend to short circuit the high pressure drop circuit and must be brought up to the pressure drop level of this circuit by the use of balance valves or by reduction of pipe size to achieve the desired pressure drop.

Flow in a pumped system will apportion itself among the various circuits so that the pressure drops between the pump and the individual circuits are just equal. The designer should therefore endeavor, by judicious pipe sizing to keep circuit pressure drops as close as possible, even though design flows may vary considerably. This will make the eventual balancing requirements simpler.

**The Design Process**

It's important to follow a coherent process of making calculations, then making choices based on those calculations in an orderly manner. Though this is not the only way to do it, the Bell & Gossett design process makes sure all the important details are covered. The most economical combination of pump size and piping size within good design parameters should be selected.

1. Calculate heat loss and select terminal units
2. Make piping layout to scale
3. Calculate required water flow to carry the load
4. Size the piping
5. Select the pump
6. Select the boiler and other accessories

This method permits very quick pump selection and pipe sizing for smaller systems. Larger systems should be evaluated using more sophisticated procedures.

**DESIGN EXAMPLE NO. 1**

A two-circuit series loop system utilizing 3/4" copper convactor baseboard is shown in Figure 14. The Six Step Method will be used for designing the system at a 20° Δt.

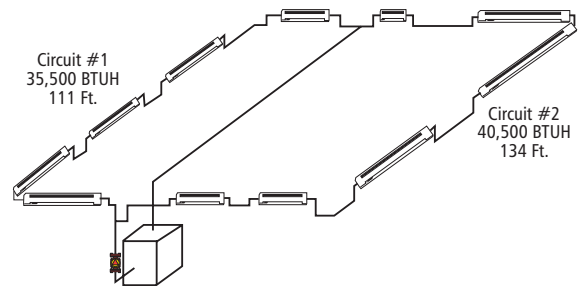

**Two Circuit Series Loop System**  
**Figure 14**

**STEP 1 RADIATION REQUIRED**

Calculate the heat loss in terms of BTUH for each room. Find the output per lineal foot of baseboard at the desired mean water temperature from the manufacturer's catalog then divide room heat loss by this figure to determine the lineal feet of radiation required in each room

**STEP 2 LAYOUT THE PIPING**

Make a scale drawing of the piping system. Because the radiation is in series, the flow in each circuit should not exceed the carrying capacity imposed by the pipe size of the radiation. See Step 3 for flow rate calculation.

Nomogram A (in the Appendix) indicates that a 1" pipe could carry the flow if a single circuit were used, but the proposed baseboard units are constructed with 3/4" copper which is limited to about 4 gpm, so the system must be split into two circuits of about 40,000 BTUH each which allows 3/4" baseboard to be used.

**STEP 3 CALCULATE REQUIRED WATER FLOW**

The total load is 76,000 BTUH. Required flow is therefore:

$$\text{Flow} = \frac{\text{Heat Load}}{500 \Delta t}$$

$$\text{Flow} = \frac{76,000}{500 \times 20} = 7.6 \text{ gpm}$$

Circuit 1 will need about 3.6 gpm, circuit 2 about 4.0 gpm

#### STEP 4 SIZE PIPING

The trunk main must be 1", each circuit will be ¾".

#### STEP 5 SELECT PUMP

A "Booster" pump is a small in-line circulator often used for systems like this. It's a simple pump whose selection requires little more than knowing the system head and flow. System flow is 7.6 gpm. System head loss could be estimated by assuming that the friction head loss everywhere in the system is near the upper limit of head loss, say 4.0 feet of head loss per 100 feet of length. The measured length of the longer circuit is 134 feet, a 50% allowance for fittings would add 67 more feet for a Total Equivalent Length (TEL) of about 200 feet. Pump head would then be estimated as:

$$\begin{aligned} \text{Pump head} &= \frac{4.0 \text{ feet of head loss}}{100 \text{ feet of length}} \times 200 \text{ feet of TEL} \\ &= 8 \text{ feet of head} \end{aligned}$$

If the head loss of other components like the boiler is low, it may be assumed that this estimate of pump head will be adequate. If higher pressure drop components are included in the system, then the published data for their head loss at the design flow must also be included.

Plot the system head and flow, the "design point", on a chart showing the performance of all sizes of booster pumps to select the specific pump required. A more detailed discussion follows.

#### STEP 6 SELECT THE BOILER

Select a boiler with a net rating equal to or slightly greater than the 76,000 BTUH total heat loss. A discussion of required air management and other equipment can be found in other Bell & Gossett publications.

### Pump Selection: the System Curve

In many cases, available pumps do not exactly fit the system requirements. In most cases, designers choose the next larger size pump. While such a selection may cause no actual problems, using the next smaller pump can save money, if an analysis of the problem indicates that this can be done.

The analysis consists of plotting a "system curve", which shows system flow versus system pressure drop, on the proposed pump curves. This analysis will determine how any given pump will perform in the system because a given pump in a system must operate at the flow rate determined by the intersection of the two curves. This is a consequence of the principle of conservation of energy. The system curve shows the relationship between flow and pressure drop in a given piping system. The pressure drop varies in a direct ratio with the square of the flow change ratio. As an example, if the flow in a piping system should double, the pressure drop would increase by a factor of four.

This simple relationship allows us to construct a curve which can be superimposed on a pump performance curve. The intersection of the two curves defines the flow, or the point of operation for the pump in the system. To illustrate this method we will assume a pump is needed for a system requiring a flow of 30 gpm at a pressure drop of 20 ft.

The pump curves in Figure 15 show that this design point falls between a PL-36 and a PL-55 pump. There is no point of intersection at exactly 30 gpm. Which pump should be used?

Using the design condition as a starting point, we can construct a system curve which will indicate the flows which either pump would produce.

Figure 15 shows the design point - 30 gpm @ 20 ft. We will determine several points, beginning with 50% flow, or 15 gpm. The system pressure drop at 15 gpm will then be the square of the flow ratio; that is the square of 0.50 which is 0.25 of the design pressure drop. 25% of 20 = 5 ft. Several other points could be determined in similar fashion.

Assumed Flow gpm	Ratio to Design Flow	Ratio to Design Head	Design Head Feet	Head at New Flow
0	0	0	20	0
15	0.50	0.25	20	5.0
20	0.66	0.43	20	8.6
25	0.83	0.69	20	13.8
30 Design	1.00	1.00	20 Design	20
35	1.17	1.37	20	27.4

Plot these points on the curve as in Figure 15 and connect them with a smooth line. This is the system curve. The line intersects the PL-55 curve at 33 gpm and the PL-36 at 27 gpm. We can now calculate the effect of either pump on system operation.

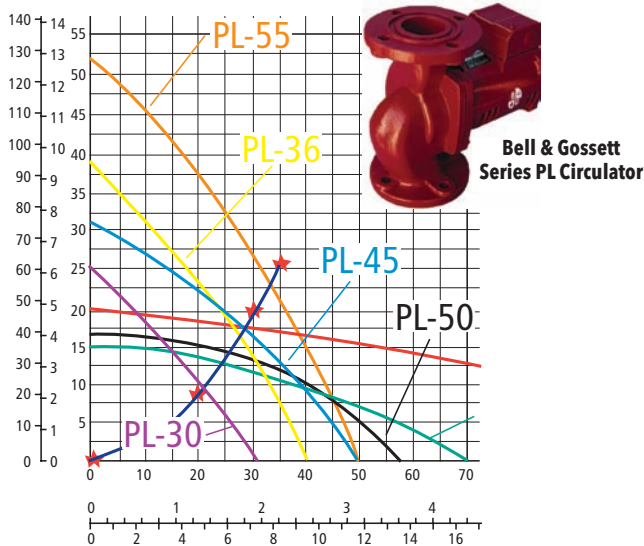

**System Curve Method for Pump Selection**  
Figure 15

If the system uses a 20° temperature drop, the lower flow of 27 gpm will increase the design temperature drop. The relationship between flow and temperature drop is an inverse one; if we double the flow we halve the temperature drop and vice-versa. We can therefore, set up a proportion to calculate the effect of reducing flow:

$$\frac{30 \text{ gpm}}{27 \text{ gpm}} = \frac{x \Delta t}{20 \Delta t} = 22^\circ$$

From this, we can determine that the system will operate at a 22° design temperature drop instead of 20°, if we use the smaller pump. This is negligible since heat output in units like baseboards or convectors is not greatly affected by small changes in flow. Output is strongly affected by changes in average water temperature so the lower flow rate could be easily compensated for by slightly raising the system operating temperature if necessary.

The effect of using the PL-55 pump at 33 gpm can be calculated in the same way. The larger pump provides 33 gpm, so the temperature change at the boiler would be about 18°F.

It is probable that the smaller pump is the better selection since it probably has a lower initial cost. It also has a smaller motor, thus reducing operating costs at least a little bit.

### The Bell & Gossett System Syzer®

Determining the required operating head and flow for small hydronic systems is relatively simple. However, an engineer must consult several different design tables, charts, and formulae to establish flow requirements, pipe size, pipe pressure drops, water velocities, pumping heads, system curves, control valve Cv ratings, etc. The B&G System Syzer® Calculator consolidates all necessary design information in a simple, easy to use circular slide rule.

The System Syzer® Calculator is useful both in final design work and in preliminary system planning. Proposed pump and pipe sizes can be quickly roughed out for estimating purposes.

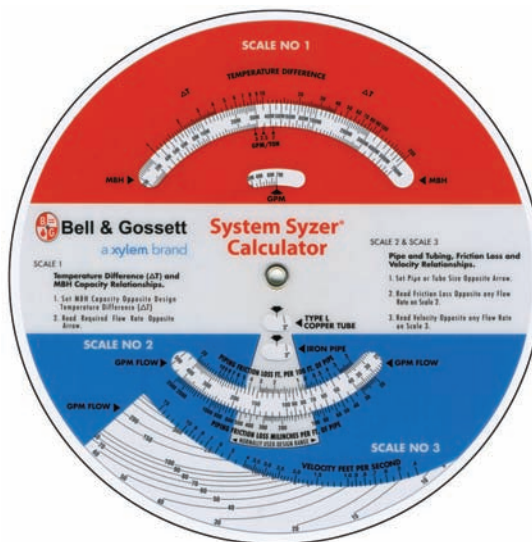

**System Syzer® Scales 1-3**  
Figure 16

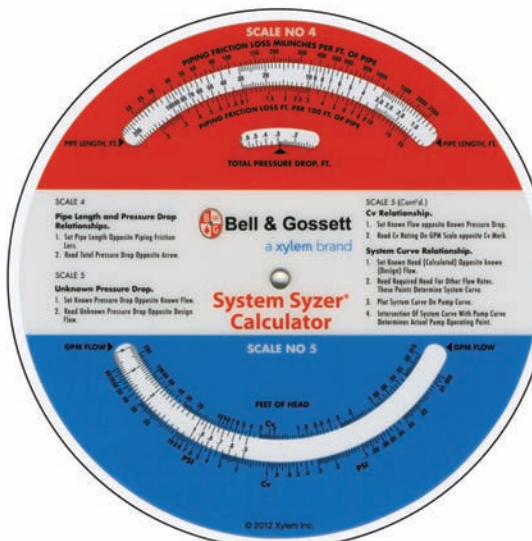

**System Syzer® Scales 4-5**  
Figure 17

The System Syzer® Calculator has five scales sequenced in the same way in which they would typically be used in designing a hydronic system. The following discussion gives the reference base of the various scales and illustrates their uses with design examples. It's best to obtain a System Syzer® calculator from your Bell & Gossett representative and use it to work through these examples.

#### Scale #1 - Load-Flow Relationships

Scale #1 is stated in terms of temperature difference, MBH and gpm. These terms are defined as follows:

- A. Temperature difference is the temperature drop (heating) or temperature rise (cooling) taken by the water as it transports heat through the system.



- B. MBH is the heating or cooling load in Btu per hour where  
1 MBH = 1000 Btu per hour; 10 MBH = 10,000 Btu per hour; 1000 MBH = 1,000,000 Btu per hour or 1M.
- C. gpm is the circulation rate in gallons per minute required to convey the design heat load at design temperature difference.

Flow rate in gpm, temperature difference in degrees F and MBH load are related by the following formula:

$$\text{Flow} = \frac{\text{Heat Load}}{500 \Delta t}$$

Scale #1 uses a specific heat equal to one and water density at 8 1/2 lbs. per gallon (60°F conditions). Changes in these properties and their effect on heat transfer have already been discussed.

Example #1: Determine required flow rate for a load of 150,000 Btu per hour at a temperature drop of 30°. Set the 150 MBH capacity in the large window under the 30° design Δt. Read gpm flow rate in the small window opposite the arrow: 10 gpm.

Example #2: Determine required flow rate for a cooling load of 20 tons at a 10° temperature rise. At 12,000 Btu per ton, a 20 ton load is equivalent to 240,000 Btu per hour or 240 MBH.

Set 240 MBH opposite 10° temperature difference and read 48 gpm on the gpm scale.

Design Temperature Difference: For many years hot water systems have been designed for a 20° temperature drop. This has been done because at a 20° temperature drop, each gpm circulated conveys about 10,000 Btu/hr. This allows simple determination of flow rates by use of the following formula:

$$\text{GPM} = \frac{\text{Heat Load}}{10,000}$$

A 20° temperature drop in typical terminal units also provides a great deal of "forgiveness"; 100% of design flow is not necessarily required to get a very high percentage of design heat transfer. While the 20° design temperature drop is still useful for small hydronic system, it is not necessarily best for a larger engineered system. Higher temperature drops permit lower flow rates, smaller pipe and pump sizes and in general return economic benefits.

Scale #1 of the System Syzer® Calculator will assist the hydronic designer in establishing minimum flow - maximum temperature difference system design through the various design approaches now available. These include primary-secondary pumping, coil re-circuiting, terminal unit flow evaluation, etc. Because of the simplicity of determining flow rates for various temperature differences, the System Syzer® Calculator will aid greatly in the design of higher temperature difference systems.

Example #3: Determine primary to secondary flow rate for a secondary zone using a heat injection pump as illustrated in Figure 18. Negligible pressure drop in a pipe which is common to two pumping circuits makes the two pumps operate independently of one another. Details of primary-secondary pumping are available in other Bell & Gossett publications.

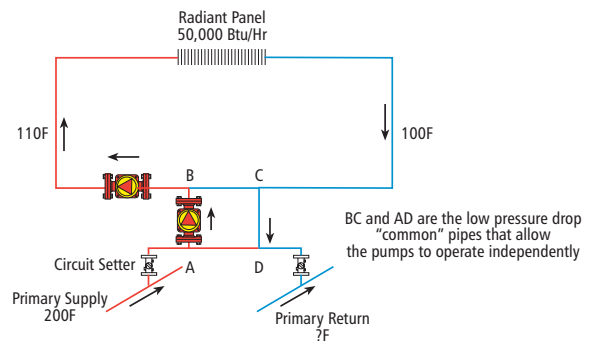
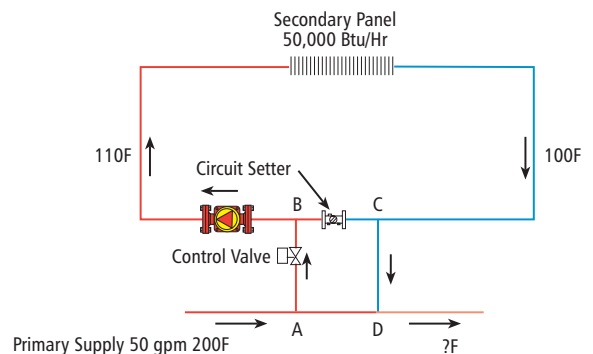

**Figure 18**

The radiant panel in the secondary zone requires 10 gpm of 110° water at a 10° Δt to provide the zone requirements of 50,000 Btu/Hr. Water at 200° is available at the primary supply pipe. At design load conditions, the required quantity of 200° water must flow from point A to point B. An equal quantity of 100° water must flow from point C to point D. The temperature difference between point A and point D of 100° (200°-100°) and the 50,000 Btu/h required for the secondary zone determine the flow required from the primary to the secondary circuit.

On scale # 1 of the System Syzer Calculator, set the 100° temperature difference opposite 50 MBH. Read the required primary to secondary flow rate: 1.0 gpm. The heat injection pump should be sized to deliver 1.0 gpm against a head determined by circuit A-B-C-D.

Example #4: There are many ways to use primary-secondary pumping principles. In the next example, a one-pipe primary loop supplies hot water to an independent secondary zone through a small control valve. Determine the temperature drop in the primary main of a one-pipe primary system with a circulation rate of 50 gpm, after supplying 50,000 Btu/h to a secondary zone as illustrated in Figure 19.



**Figure 19**

As in the preceding example, the flow from A to B is 1.0 gpm. Since the total primary flow is 50 gpm, a flow of 50 minus 1.0 or 49 gpm of 200° water will flow from point A to D. At point D, 1.0 gpm of 100° water will blend with the 49 gpm of 200°



water to give 50 gpm, but at a reduced temperature. What is the temperature downstream of point D?

Set 50 gpm in the small window of scale #1. Directly opposite 50 MBH read the temperature difference: 2°. Therefore, the temperature beyond point D is 200° minus 2° = 198°.

### **Scale #2 - Flow-Pressure Drop Relationships and Pipe Sizing**

Scale #2 relates gpm flow rate to friction loss rate for both type "L" copper tubing and for Schedule 40 steel pipe. Friction loss is stated in terms of milinches per foot and in feet per 100 feet of pipe. Either milinches per foot or feet per 100 feet are valid expressions of pipe friction loss. Defining these terms:

- A. Milinch means 1/1000 of an inch or 1/12,000 of a foot of pressure energy head.
- B. Feet per 100 feet expresses the rate of pipe friction loss as foot head of energy loss per 100 feet of pipe.

The pipe friction loss data used as a basis for construction of scale #2 are The Hydraulic Institute Values, The ASHRAE-Giesecke Chart Values and The ASHRAE Unified Pressure Drop Chart data. Both the Hydraulic Institute values and The ASHRAE Unified Pipe Pressure Drop data are based on Moody's pipe pressure drop correlation. Though established by an entirely different experimental approach, the Giesecke Chart values closely approximate Moody's correlation—generally accepted as most valid. Friction loss indicated for type "L" copper tubing has been derived from the ASHRAE Handbook.

Scale #2 is based on a water temperature of 60°. When used for hot water design with temperatures in the area of 200° piping pressure drop is over-stated on the order of 10% since pressure drop decreases slightly as water temperature is increased. However, the difference is not sufficient to warrant correction.

The normally used range of pipe friction loss rates is indicated by a white wedge shape band on scale #2. Experience indicates that the optimum friction loss range is from 100 to 500 milinches per foot or from approximately 0.85 foot to 4.5 feet per 100 feet of piping.

Example #1: Determine pipe size for 70 gpm flow rate. Set the rule so that 70 gpm appears in the "white" or optimum design range on the rule. It is apparent that either 2½" or 3" pipe can be used. Setting the arrow to 2½" pipe size in the iron pipe window, a pipe friction loss rate of 3.6' per 100' appears opposite 70 gpm. A simultaneous reading on scale #3 establishes that at 70 gpm a water velocity will be 4.5' per second.

Setting the rule to 3" pipe illustrates that at 70 gpm flow rate a pipe friction loss rate of 1.2' per 100' will occur. A simultaneous reading on scale #3 indicates a water velocity of 3.0' per second.

Setting the rule to any pipe size then provides a complete flow-pressure drop-velocity relationship for that particular pipe size. In the example, either 2½" or 3" piping, could be used for the flow rate of 70 gpm, depending on circuit needs, available pumping head, etc. In many cases, the hydronic system designer may also wish to evaluate water velocity as this affects pipe sizing.

### **Scale #3 - Water Velocity**

Scale #3 establishes water velocity in feet per second for any given flow rate through the particular pipe size. Water velocity in the hydronic system should be high enough to carry entrained air in the water stream—yet not high enough to cause noise. Water velocity should be above 1½ to 2 feet per second in order to carry entrained air along with the flowing water to the point of air separation (Rolairtrol, EAS, etc.) where the air can then be separated from the water and directed to the compression tank or vented from the system. See other Bell & Gossett publications for details about air management in hydronic systems.

Piping noise considerations establish the upper velocity limitations. For piping 2" and under a maximum velocity of 4 feet per second is recommended. Note that in smaller pipe sizes, this velocity limitation permits the use of friction loss rates higher than 4 feet per hundred foot.

Velocities in excess of 4 feet per second are often used on piping larger than 2 inch. It seems apparent that water velocity noise is caused by entrained system air, sharp pressure drops, turbulence, or a combination of these which in turn cause flow separation, cavitation and consequent noise in the piping system.

It is generally accepted that if proper air management is provided to eliminate air and reduce turbulence in the system, the maximum flow rate can be established by the piping friction loss rate; at 4 feet per 100 foot. This permits the use of velocities higher than 4 feet per second in pipe sizes 2" and larger.

Example #1: A supply main in an apartment building has a design flow rate of 1600 gpm. Select the proper pipe size.

Setting Scale #2 at 8" pipe shows that at 1600 gpm, the pipe friction loss is 3.8 feet per hundred feet. Scale #3 shows that a water velocity in excess of 10 feet per second will result.

Setting the rule at 10" pipe illustrates a pressure drop of 1.2 feet per 100 foot and a water velocity of 6.5 feet per second, less likely to cause noise. Because the main must run adjacent to living quarters, a critical location concerning possible noise generation, the 10" pipe would be preferred.

### **Scale #4 - Circuit Piping Pressure Drop**

Scale #4 provides a simple method of determining required pump head from the equivalent circuit piping length and the resistance per unit length. To use Scale #4, it is first necessary to establish the total equivalent length (TEL) of the piping circuit. As all fittings have a greater resistance to flow than a straight length of pipe, this must be taken into account. TEL is a summation of the straight lengths of pipe plus the equivalent length of valves fittings, etc.

In preliminary pipe and pump sizing, it is common practice to consider the resistance of fittings in a circuit to be a percentage of the straight length of pipe (usually 50%). In making a more accurate pressure drop calculation, the actual resistance of each fitting should be considered. The table on the back of the System Syzer Calculator envelope indicates the equivalent length of most commonly used fittings. Recent research has shown that these equivalent lengths tend to

overstate the fitting head loss by some amount depending on type of fitting and fitting size. Therefore, use of these values builds in a small safety factor.

Example #1: A circuit flowing 200 gpm is sized at 4" providing a friction loss of 2.3 feet per 100 feet. The circuit has a TEL of 130 feet. What is the total circuit pressure drop?

Set 130 foot pipe length opposite 2.3 feet per 100 feet and read 3 feet as the total circuit pressure drop.

In some instances, the system designer may wish to make a preliminary pump selection and proportion its available head over the longest circuit in the system to determine the average resistance rate on which the piping should be sized.

Example #2: A designer is evaluating a pump with an available head of 50 feet at the design flow. The longest circuit in the system has a TEL of 1500 feet. At what average friction loss rate should the piping be sized?

Set 50 foot head opposite the arrow. At the TEL of 1500 feet, a resistance of 3.3 feet per 100 feet is indicated.

### Scale #5 - Determining Unknown Pressure Drops, System Curves and Control Valve Cv ratings.

Scale #5 is based on the relationship which exists between flow and system resistance where the head varies approximately as the square of the flow. Scale #5 can be used in several ways: to determine an unknown pressure drop from a known pressure drop, to establish system curve relationships, to select control valves to their Cv ratings, and to convert between pressure gauge readings in psi and head loss values in feet of head.

To determine unknown pressure drop from a known pressure drop condition, set the known pressure drop opposite the known flow and read the unknown pressure drop opposite the design flow.

Example #1: From manufacturer's data, a chiller has a pressure drop of 12 feet at 100 gpm. Determine pressure drop at a flow of 150 gpm.

Set 100 gpm in the window of scale #5 immediately below 12 feet of head. Read the unknown pressure drop at 150 gpm: 27 feet.

Scale #5 of the System Syzer® Calculator can also be used to select control valves by their Cv rating.

Example #2: In the example of Figure 19, a control valve was used to supply zero to 2.9 gpm from the primary circuit to the secondary circuit in order to maintain circuit temperature. Control valves must be selected for adequate pressure drop in order to insure proper operation. They are usually selected by their Cv rating. Control valve selection is discussed in detail in other Bell & Gossett publications. In Figure 20, a control valve for use with a secondary zone is to be selected for a 3 psi differential at 2.9 gpm. Determine the required control valve Cv rating.

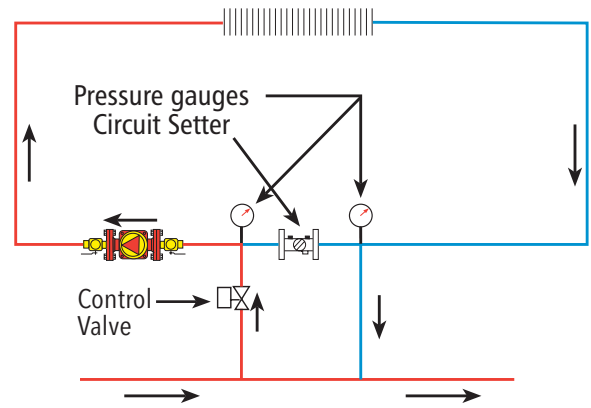

Figure 20

On scale 5, set 2.9 gpm directly opposite 3 psi. Read the required valve Cv rating at 1 psi: approximately 1.7. If a control valve with a Cv of approximately 1.7 can be installed, then with the control valve open and the secondary pump on, the pressure drop across the Circuit Setter balance valve should be adjusted to 3 psi. This will set the flow into the secondary zone to the design point of 2.9 gpm.

To plot a system curve, set the known (calculated) head loss opposite the known (design) flow. Read the required head for several other flow rates. These points determine a system curve. Plot the system curve on a pump curve. The intersection of the system curve with the pump curve determines the actual pump operating point (on open systems, adjust the system curve in accordance with the total static head).

Example #3: Your analysis of a closed loop piping system indicates that a 200 gpm flow rate results in 30 feet of head loss. Calculate the resistance at several other flow rates plot a system curve on the pump curves illustrated below and determine their actual operating points.

Set 200 gpm in the window below 30 foot head. Read the resultant head at 100, 150, 250 and 300 gpm. These points establish the system curve for this "friction only" system.

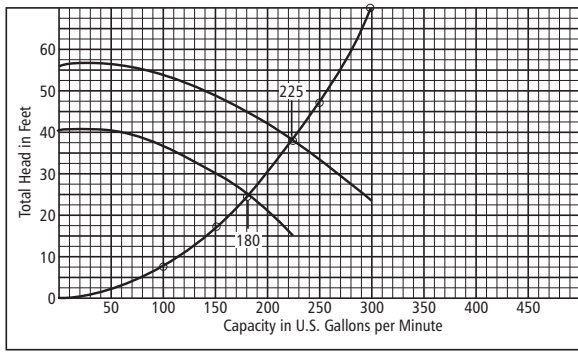
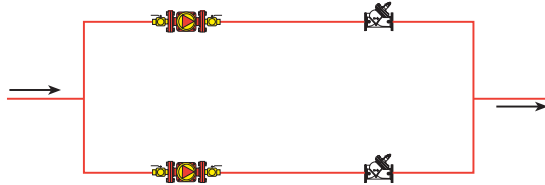

**Figure 21**

Operation of the pump in the piping circuit described by the system curve must be at the intersection of the pump curve and the system curve. This is because of the first law of thermodynamics – energy in must equal energy out. Energy put into the water by the pump must exactly match the energy lost by the water as it flows through the piping system. The point of intersection is the only point that can meet this basic engineering law. The specific points of operation for the two pumps illustrated are 180 and 225 gpm.

**Pumps in parallel**

The application of pumps in parallel always requires a system curve – pump curve analysis. When two identical pumps are placed in parallel, each pump operates at the same differential head and each supplies 1/2 the total system flow.



**Parallel Pumps**  
**Figure 22**

A parallel pump curve can be developed by doubling the flows at any constant head for the single pump curve.

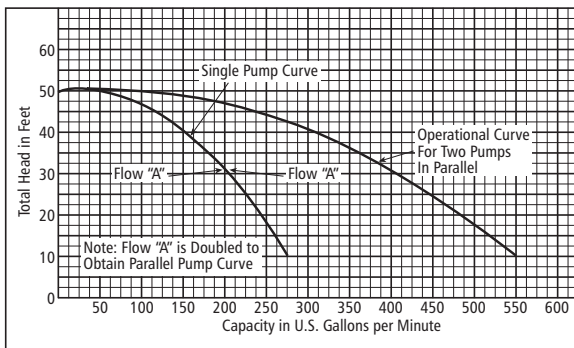

**Parallel Pumps Curve**  
**Figure 23**

The system curve for any piping circuit must be plotted on the developed parallel pump curve. With both the pumps in operation, the system flow and head will be at point A. However, each pump will operate at point B. This is because each pump supplies half the total flow and consumes half the power requirement.

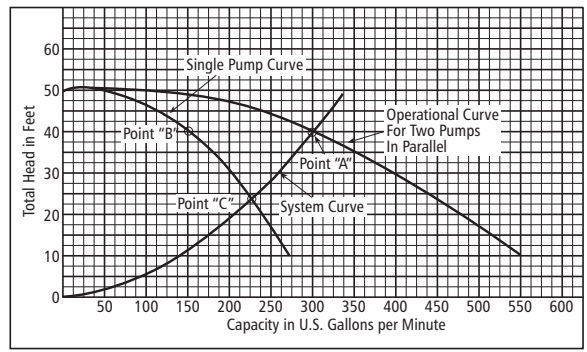

**System Curve Plotted on Parallel Pumps Curve**  
**Figure 24**

When only one pump is operating, the point of operation is at C. The operating point shifts to the right on the pump curve, which means that the single pump can provide more than 50% of design flow. This means that a single pump operating alone will draw more power than when operating in parallel: It is important that each pump be supplied with a motor large enough to operate at point C.

Note that simply adding a second pump without changing the existing system will increase the flow, but will not double it because the system curve was unchanged.

**Two - Pipe System Design Example**

A three zone heating system using air handling coils will be used to illustrate the procedure to be followed in sizing a typical two-pipe system, calculating its pressure drop, and selecting a pump. In order to clearly understand this process, it's best to obtain a System Syzer® from your local Bell & Gossett representative while you work through this example.

The system is illustrated in Figure 25. The water is heated by means of a heat exchanger. Heat exchangers are discussed in more detail later. The system is equipped with a Rolairtrol air separator and vent. The pump is base mounted, end suction, equipped with a Triple Duty Valve at the discharge and a Suction Diffuser at the suction. The system expansion tank is located near the pump suction.

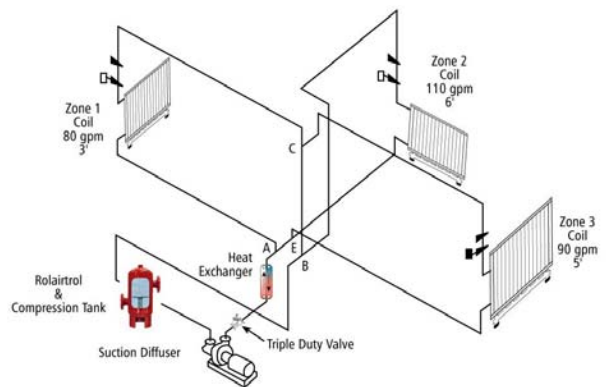

**Two-Pipe Fan Coil System**  
**Figure 25**

The coil pressure drops at their design flow rates are shown on the drawing. Each air handler coil was selected to provide design heat transfer at design delta tee. For example, in a typical heating system the flow rate for standard water at 20° Δt is easily found by dividing the heat load in BTUH by 10,000.

Zone	Heating Load at 20° Δt (BTUH)	Flow rate (gpm)
1	800,000	80
2	1,100,000	110
3	900,000	90
		280

But suppose it's a typical chilled water system designed for a 12° Δt. The cooling loads would require greater flow.

Zone	Heating Load at 12° Δt (BTUH)	Flow rate (gpm)
1	800,000	130
2	1,100,000	180
3	900,000	150
		460

Scale #1 of the System Syzer® can easily be used to calculate the design flow rate for each zone. Line up the heat load in MBH in the white scale with the 12° Δt in the red scale to get the chilled water flow rates required.

### Equipment Room Head Loss

The equipment room piping is common to all three zones. The pressure drop between points A and B will be calculated separately for each of the three zones in order to balance the flow. The greatest head loss zone will determine the pump head required.

The total flow rate of 280 gpm dictates the equipment room pipe size and equipment selection since all of this equipment must carry the total flow. The system will use steel piping. Scale #2 of the System Syzer can determine the pipe size.

Adjust the total flow rate of 280 gpm within the white arc in Scale #2 defined by the maximum and minimum friction loss rates recommended for hydronic systems. Note that two choices exist:

- A 3" pipe would have a friction loss rate much greater than the maximum allowable 4.5 feet head loss per 100 feet of equivalent length. From Scale #3, the velocity would be over 12 feet per second; much too high.
- At 280 gpm, a 4" pipe would have a friction loss rate of 4.3 feet head loss per 100 feet of length, and a velocity of about 7.0 f/s. This is within normal design limits.
- A 5" pipe would have only 1.4 feet of head loss per 100 feet of length, so the total head loss in the equipment room would be significantly less. Low head loss in the equipment room results in systems that are easier to balance and easier to control at part load. However, the cost of the 5" pipe and fittings would be greater than the 4" alternative, and 5" pipe may not be commonly available.

The equipment manufacturer's catalogs show the following equipment data:

Heat exchanger	3 feet head loss at 200 gpm
Rolairtrol with strainer	4" Cv=135 5" Cv=215
Rolairtrol without strainer	4" Cv=370 5" Cv=580
Triple Duty Valve	Minimum of 3 feet of head loss at 280 gpm to provide accuracy as a flow meter
4" Suction Diffuser	2.25 psi at 280 gpm

Note that the manufacturer's friction loss data is given in a variety of ways. Scale #5 of the System Syzer® can help in reducing this data to consistent units which can be summed to determine the total equipment room head loss.

### Heat exchanger



**Brazed plate heat exchangers**  
**Figure 26**

The heat exchangers in Figure 26 use very hot water directly from the boiler, flowing across one side of the corrugated stainless steel plate then back to the boiler. Heat transfers through the plate to the heating system water on the other side of the plate which will be circulated through the system. It is the pressure drop inside the heat exchanger that is of concern in this example. The boiler water circulation must be handled by a separate pumping system. Heat exchanger data is provided in units of feet of head loss. These units are preferred in order to simplify pump selection since pump curves are usually stated in feet of head. The manufacturer says the heat exchanger has 3 feet of head loss at 200 gpm. At design flow of 280 gpm, the head loss will increase. Scale #5 can be used to calculate the actual head loss at design flow. On scale #5, align the given values of flow, 200 gpm in the white scale and 3 foot head loss on the inner blue scale. Without moving the scale, find 280 gpm and read a bit less than 6 feet head loss on the inner scale. Note that Scale #5 has both feet of head loss and psi pressure drop. Be sure to use the right scale.



### Rolairtrol air separator

Water carrying air bubbles enters through the tangential nozzle at the top. Centrifugal acceleration separates air from water, allowing the air to escape from the top, and the air-free water to continue to circulate to the system from the other nozzle. Rolairtrols are also available without the strainer.



**Rolairtrol air separator  
Figure 27**

Rolairtrol data is given as a Cv. Remember that the Cv is the flow in gpm at 1 psi Δp. Scale #5 has a Cv index at 1 psi on the outer blue scale or 2.31 feet of head on the inner scale. To evaluate the head loss for the 4" Rolairtrol, rotate the scale until the Cv index is at 135, then read 10 feet of head loss opposite 280 gpm. The 5" Rolairtrol has a larger Cv, 215. At 280 gpm it has about 4 feet of head loss. Also notice that the addition of a strainer in the Rolairtrol tends to reduce Cv, or increase head loss. Unless there is an important reason to include a strainer, it's best to choose the Rolairtrol without one.

### Triple Duty<sup>®</sup> Valve



**Triple Duty Valve  
Figure 28**

As the name implies, the Triple Duty<sup>®</sup> Valve provides three important functions at the pump discharge:

- a. Isolation valve for pump service
- b. Check valve, to prevent backward flow

c. Balance valve, to eliminate the excess flow which will be caused by an oversized impeller

Angle pattern valves also act as an elbow at the pump discharge, and all Triple Duty Valves are designed to serve as rough flow meters.

Details of Triple Duty Valve selection are covered in other Bell & Gossett publications, but for this example, observe that the fully open valve must have about 3 feet of head loss at full flow in order to measure flow reasonably accurately.

### Suction Diffuser



**Suction Diffuser  
Figure 29**

Suction diffusers provide proper entering conditions at the pump in order to reduce wear and insure the pump performs as designed. While they are not always required, they often save equipment room space, especially with end-suction pumps. The Suction Diffuser data is given as 2.25 psi at design flow. Scale #5 can be used to convert to feet of head by aligning any flow rate line at 2.25 psi on the outer scale to read the corresponding head loss of 5.2 feet of head loss.

Equipment room component head loss at design flow:

Heat exchanger	6.0'
4" Rolairtrol w/o strainer	1.3'
3DS-4B Triple Duty Valve	5.0'
Suction Diffuser	5.2'
Total	17.5'

In addition to the equipment room components, the equipment room portion of the system contains the following piping and fittings to the entrance of the tees at points A and B:

- 9 - 90° Ells
- 1 - NPT Gate Valve
- 36' Piping

### Piping Equivalent Lengths

Use the table on the System Syzer jacket to find the equivalent lengths.

Straight Pipe	36.0'
4" NPT Gate Valve	2.5'
9 - 4" Ells	9 x 13 = 117.0
Total Equivalent Length=	156'
156' of 4" Pipe @ 4.3' / 100 Ft. =	6.7 Ft.



Scale #4 of the System Syzer® can also be used in this calculation.

Line up the TEL, 156 feet, with 4.3 Ft head loss per 100 feet TEL, then read about 6.7 feet of total head loss in the window.

Equipment Room Pressure Drop B to A = 17.5' for all the components PLUS 6.7' for the piping of 24.2 feet at design flow.

### The rest of the system

The next step is to evaluate the pressure drop in each of the three zones. One of those zones will have the highest pressure drop at design flow. Adding that zone pressure drop to the equipment room pressure drop will determine the pump head required. But if the pump provides enough differential across points A-B to satisfy the highest pressure drop zone, it will, by definition, provide too much across the other two, and they will see excess flow. In this example, Circuit Setter balancing valves will be used to eliminate this excess flow in the lower-pressure-drop zones. Other devices for achieving flow balance certainly exist; their use is covered in other Bell & Gossett publications.

Each zone has a modulating two-way valve on the coil return. They are required in order to reduce coil flow, and therefore heat transfer, at part load conditions. These valves must be selected to:

- Operate properly in order to adjust the system performance to part load conditions
- Aid in balancing the individual circuits to one another.

It will be necessary to calculate the zone pressure drop exclusive of the control valves in order to accomplish this.

The pressure drop calculation for each zone is as follows. Use your System Syzer® to verify each of these calculations.

#### ZONE 1 - 80 gpm from A to B

Coil	3.0 Ft.	
Piping 3" @ 1.6' / 100 ft. (A-C) 80 gpm		
Straight Pipe	257'	
Fittings - 3"		
2 - Tees - Branch Flow @ 9		18'
5 - 90° Ells @ 4.0		20'
Total	295' @ 1.6' / 100'	4.7 Ft.
Piping 4" @ 1.7' / 100 ft. (C-B) 170 gpm		
Straight Pipe	10'	
2 Tees - Branch Flow @ 12.0		24'
	34' @ 1.8' / 100 Ft.	0.6 Ft.
Balance Valve (2½" Circuit Setter set to 0)		2.2 Ft.

A Circuit Setter slide rule is available to determine the actual head loss in the valve at each setting. Initially, all these balancing valves will be set at the zero index mark to provide minimal pressure drop. Later, after the differences in pressure drop among all the zones are determined, we can set two of these balancing valves to provide resistance in the zones that need it to prevent excess flow that would otherwise occur.

**ZONE 1** - Pressure Drop (Less two-way valve) 10.5 Ft.

#### ZONE 2 - 110 gpm from A to B

Coil		6.0 Ft.
Piping 4" @ 2.3' / 100 ft. (A-E) 200 G.PM		
Straight Pipe	2'	
2 Tees - Through Flow @ 5.5		11'
	13' @ 2.3' / 100 ft.	0.3 Ft.

#### Piping 3" @ 2.8' / 100 ft. (E-B) 110 gpm

Straight Pipe	149'	
1 Tee - Through Flow @ 4.0		4'
1 Tee - Branch Flow @ 9.0		9'
4 - 90° Ells @ 4.0	16'	
	178' @ 2.8' / 100 ft. =	5.0 Ft.
Balance Valve (2½" Circuit Setter set to 0)		4.0 Ft.
Zone 2 - Pressure drop (Less two-way valve)		15.3 Ft.

#### ZONE 3 - 90 gpm from A to B

Coil		5.0 Ft.
Piping 4" @ 2.2' / 100 ft. (A-E) 200 gpm		
Straight Pipe	2.0'	
1 Tee - Through Flow @ 5.5		5.5'
	7.5' @ 2.3' / 100 ft.	0.2 Ft.

#### Piping 3" @ 2' / 100 ft. (E-C) 90 gpm

Straight Pipe	215'	
2 Tees - Branch Flow @ 9.0	18'	
5 - 90° Ells @ 4.0'	20'	
	253' @ 2.0' / 100 ft.	5.0 Ft.

#### Piping 4" @ 1.7' / 100 ft. (C-B) 170 gpm

Straight Pipe	10'	
2 Tees - Branch Flow @ 12.0		24'
	34' @ 1.7' / 100 ft.	0.6 ft.

Balance Valve (2½" Circuit Setter set to 0) 2.8 Ft.

Zone 3 pressure drop (Less two-way valve) 13.6 Ft.

Now that the pressure drop of each zone has been calculated, the next step is to select the control valves for each zone. In order to provide stable flow conditions, and good control at part load, the control valves should be selected for initial pressure drops at least equal to the coil pressure drop if possible in order to minimize distortion of the valve's inherent flow-stem position characteristic. Select the control valve in the circuit with the highest pressure drop first. Then select the other valves to help balance their circuit pressure drop to the first. The number and size of control valves available is limited, so we should expect to find we must compromise in selecting the best size.

Zone 2 has the highest pressure drop, 15.3 Ft. with its coil pressure drop of 6'. We'll attempt to find a valve with 12' pressure drop at the required flow 110 gpm. Use scale #5 to calculate the desired Cv by aligning 12' and 110 gpm, showing Cv=48.

Valves should generally not be sized for over 20' pressure drop because of velocity and other problems. We will assume the closest selection we can find is a 3" valve with Cv = 44.

What's the actual pressure drop?

Align the Cv index at 44, find the design flow of 110 gpm and see the actual head loss of 14.5'.

The pressure drop of Zone 2, including the valve, will then be the 15.3' previously calculated PLUS 14.5' for the valve, for a total of 29.8'.

Zone 1 has a pressure drop, exclusive of its control valve, of 10.5', which means that we must try to select a valve for the difference between 10.5 and 29.8' in order to balance it to Zone 2. This difference is 19.3', close to the allowable 20' maximum pressure drop. A valve which provides 20' resistance at 80 gpm would require a Cv = 27. The closest selection available is a 2½" valve, Cv = 29, which has a pressure drop of 17.6' at 80 gpm. Adding this to the calculated 10.5' pressure drop for the zone yields 27.8' total pressure drop.

Zone 3 requires a valve with a pressure drop of 16.2' (29.8 - 13.6) to balance it to Zone 2. The control valve must therefore provide 16.2' of pressure drop at 90 gpm, requiring a Cv of 34. The closest selection available is found to be a 2½" valve, Cv = 36. The pressure drop of this valve at 90 gpm flow is 14.4'.

The zone pressure drops, including control valves, are now as follows:

	Head Loss Coil, Pipe, Fittings	Head Loss Control Valve	Total Head Loss (Feet)
Zone	110.5'	17.6'	28.1'
Zone	215.3'	14.5'	29.8'
Zone	313.6'	14.4'	28.0'

In order to balance Zone 1 to Zone 2, the Circuit Setter in Zone 1 will have to be set to provide 1.7' of additional resistance, or a total of 3.9' after including the 2.2' (when it's set at zero) resistance already included in the zone pressure drop.

Bell & Gossett tools and publications are available to show exactly how to adjust the Circuit Setters. A 2½" Circuit Setter adjusted to an index mark of 9 will provide the required 3.9' head loss at the 80 gpm flow.

Zone 3 requires 1.8' (29.8 - 28.0) to balance it to Zone 2. Adding the 2.8' (when it's set to zero) pressure drop already included in the calculations requires a setting to provide 4.6' total pressure drop. A 2½" Circuit Setter, when set at 8 will provide this pressure drop at the 90 gpm zone flow.

All three zones are now in balance at their respective design flows, with pressure drops corresponding to the Zone 2 pressure drop of 29.8'. Notice that the Circuit Setter in Zone 2 is still set "wide open". There's no point in adding resistance at the balancing valve in Zone 2 because it's already the highest head loss zone. Remember, at the beginning of the process, we didn't know which of the zones would be the highest in pressure drop, so we included a balancing valve in each zone.

The total system pressure drop is:

Equipment Room to A&B	24.2'
Zones, from A&B	29.8'
Total Pressure Drop	54.0'

A pump may now be selected for 280 gpm @ 54' head. In this simple example, a constant rpm pump could be used. As systems increase in size, and as energy costs increase, variable speed pumps become more attractive. Those systems would benefit from the application of "automatic flow limiters", and "pressure independent control valves". These more sophisticated valves automatically adapt to changes in differential pressure as other control valves open and close, and as the pump speed changes in response to those valves. The design of variable speed systems is covered in other Bell & Gossett publications.

## Pump Selection

In the earlier example, booster pumps were used because they are very simple, require few decisions, and illustrate the basics very well. In larger systems, the designer must choose among many larger pump types:

- In-line or base-mounted
- Single suction or double suction
- Close coupled or flexibly coupled

It's very common to use a base-mounted, flexibly coupled, end suction pump for an application like the one in this example, but there may be good reasons to use a different type. A discussion of the benefits of other pump types can be found in other Bell & Gossett publications.

ESP PLUS is a design tool available from your Bell & Gossett representative. It helps guide you through the pump selection process, assuming you have already completed the system design, and you know the head and flow required.

The next figure shows the ESP PLUS entering screen.



**Circuit Setter Slide Rule**  
**Figure 30**

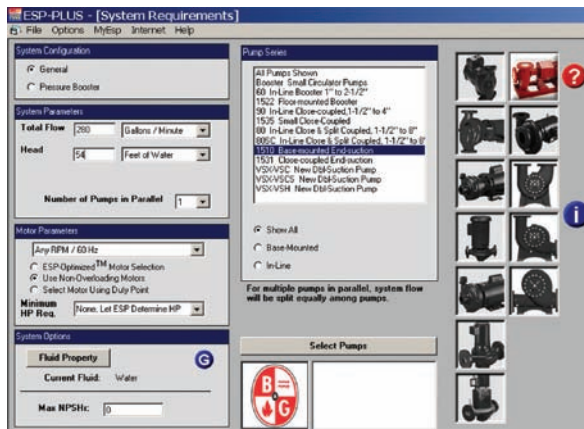

**ESP Plus Opening Window  
Figure 31**

Enter the system head and flow requirement and select the Series 1510 end suction type pump, see Figure 32. The pump discharge nozzle size is used to designate the pump size for this type of pump. Letters following the nozzle size refer to the largest impeller diameter and design modifications which may have been applied to the original pump design.

Other types of pumps use different methods for designating pump size.

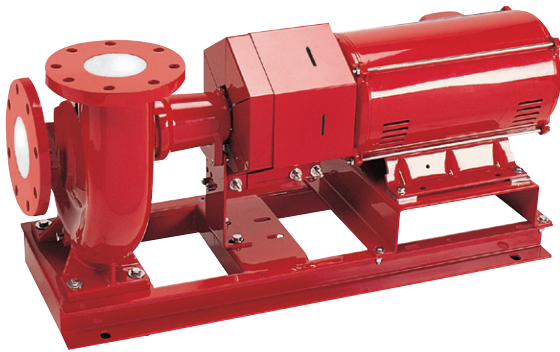

**Bell & Gossett Series 1510 End Suction Pump  
Figure 32**

right end of the smallest diameter impeller. That's a very poor selection, even though it's the lowest cost pump. A detailed explanation of why it's such a poor choice is available in other Bell & Gossett publications, but briefly stated:

- The 2½" pump would require a high rpm motor, possibly adding to procurement lead time, and maybe generating noise at the high rpm.
- The smallest diameter impeller offers no room for adjustment if the system's head loss has been overstated. "Trimming" an impeller is often a useful way to reduce operating cost if the original selection is oversized for the system. The minimum size impeller used in the 2½" AB pump can't be trimmed.
- Any pump which operates at the extreme end of its curve will probably be less efficient and will be more likely to experience component failure compared to another pump operating closer to the middle of its curve.

If this pump is such a poor choice, why did it appear on the list?

**Computer applications-as good as they are-can't replace the judgment of an experienced designer. You must select the pump; and to help you do it, you could re-rank the pumps in order of efficiency.**

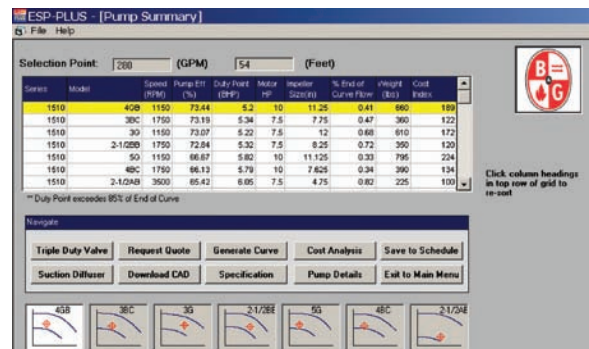

**Re-Rank the Pump Candidates by Efficiency  
Figure 34**

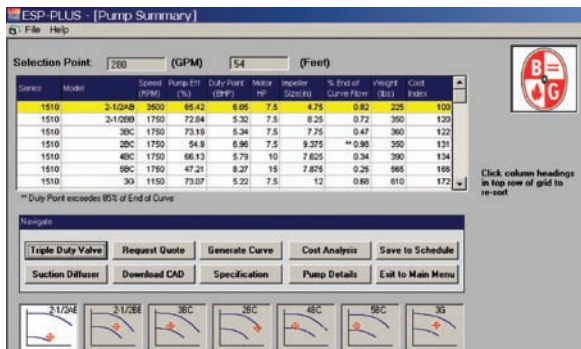

**ESP Plus Pump Summary  
Figure 33**

All of the pumps on this second screen are capable of providing the system head and flow. They are ranked in order of increasing cost, so a simple analysis would choose the 2½AB pump—the least expensive alternative. But note the little thumb-nail sketch of the pump's performance. It shows that this 3500 rpm pump is operating at the extreme

The larger, and more expensive, 4GB pump is more efficient, and is operating closer to the middle of its curve, but it is equipped with an 1150 rpm motor. That motor may take longer to procure, may be more difficult to replace in the future. As an alternative, consider the smaller, less expensive 3BC. Its efficiency and point of operation are similar to the 4GB, but it uses a more readily available 1750 rpm motor. It may be a better choice in terms of the total "life cycle cost" of owning the pump. Clicking on the "Generate Curve" button will provide a lot more information to help you make decisions about the pump.



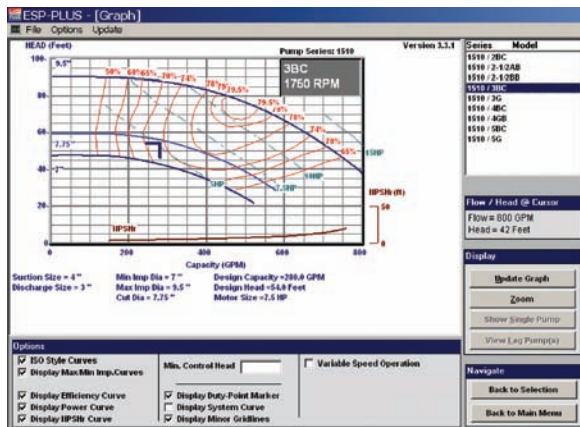

**Series 1510 3BC Pump Curve  
Figure 35**

The actual pump curve for the Series 1510, 3BC 1750 rpm pump being evaluated is in Figure 35. Bell & Gossett plots pump curves strictly in accordance with the Hydraulic Institute/ANSI standards for pump testing. The coordinates are flow in gallons per minute versus head in feet. For a pump, the vertical axis represents the amount of work the pump applies to each pound of fluid, foot-lbs work per pound of fluid. In a closed loop system, that work is used to overcome the system friction loss, 54 feet, already calculated.

The largest impeller that Bell & Gossett will supply in this pump has a diameter of 9.5". It's also the most efficient, about 80%, at a flow rate of about 500 gpm. Lines of constant efficiency are usually plotted like the growth rings of a tree. Note that this pump operating at the system design point, 280 gpm and 54 feet, would need only a 7.75" impeller. The best efficiency that impeller is capable of achieving is 78% at about 400 gpm. At the design point, efficiency is about 73.2%

For pumps like this, the designer must also select a motor. The motor horsepower is calculated by the formula:

$$\text{Brake Horsepower} = \frac{\text{GPM} \times \text{Feet of Head} \times \text{SG}}{3960 \times \eta_{\text{pump}}}$$

Where:

SG is the specific gravity of the fluid. For standard water, SG=1

$\eta_{\text{pump}}$  is the efficiency of the pump at its operating point, about 73.2%

Lines of constant horsepower--for this pump, 5, 7.5, 10, and 15 HP-- are also drawn on the pump curve. These lines represent all the combinations of head, flow and efficiency that would require that much horsepower. For the example system, the point of operation lies just a bit above the 5 hp line:

$$\text{BHP} = \frac{280 \text{ gpm} \times 54 \text{ feet} \times 1}{3960 \times 0.732}$$

$$\text{BHP} = 5.2 \text{ hp}$$

If we had selected the "Select Motor Using Duty Point" option shown on the initial ESP Plus screen, then ESP Plus would have recommended a 7.5 HP motor, the smallest standard size motor that could provide 5.2 hp without operating in the

service factor of the motor. On that initial screen we selected the option, "Use Non-Overloading Motors". The pump curve illustrates the effect of that choice. If the flow were to increase above 280 gpm, the operating point would move to the right on the impeller curve. The end of the impeller curve rises well above the 5 HP line, but never above 7.5 hp.

Many designers choose to avoid relying on the service factor, some motors don't have one, and all designers should hesitate to rely on the motor starter to prevent overload, so they choose a larger, "non-overloading" motor. That's the choice we made in the initial ESP PLUS screen. This pump would use a little more than 7 hp if it were to operate at the far end of its curve. ESP PLUS would therefore recommend the next size larger, and more expensive, 7.5 HP motor.

All of these, as well as many more details are provided by ESP PLUS by clicking the "Pump Details" button.

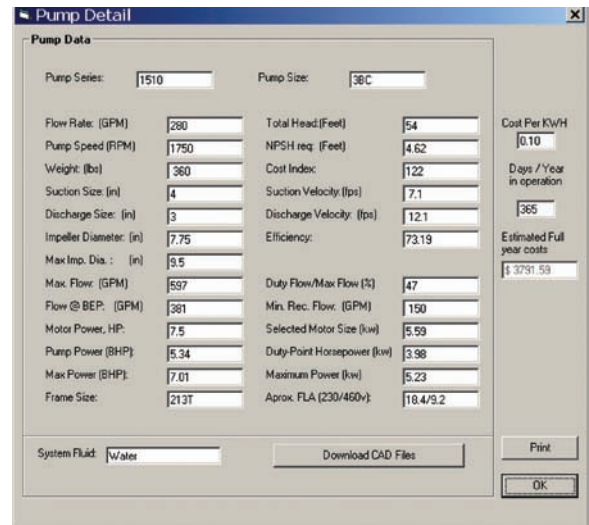

**Bell & Gossett Series 1510 3BC Operating Details  
Figure 36**

### The System Curve

Earlier, we showed how the System Syzer<sup>®</sup> calculator can be used to draw a system curve. ESP PLUS can do that with the click of a button. On the ESP PLUS pump curve, click on "Display System Curve", then "Update Graph" to show the pump and system curves together. The design point, 280 gpm and 54 feet of head, represent Q1 and h1. ESP Plus generates a number of points and plots them on the pump curve.

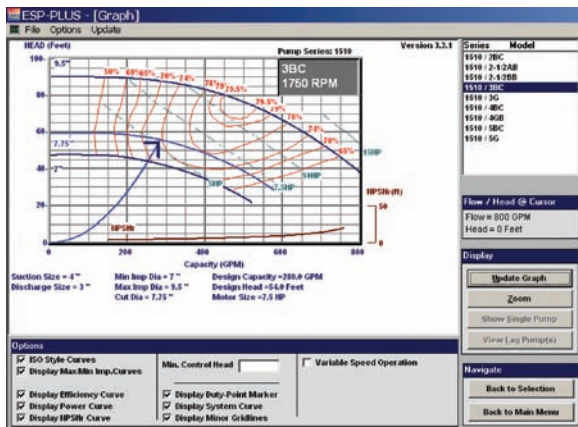

**Pump and Closed System Curve  
Figure 37**

### Pumps in parallel

The real value of applications like ESP PLUS comes in evaluating alternatives, for example, using two smaller pumps in parallel. Using the same design point, select two parallel pumps in the initial ESP PLUS screen. Two smaller close-coupled, end suction pumps would perform as shown in Figure 38. Note that ESP PLUS constructs the composite curve representing the combined effect of both pumps running. Turning off either pump shifts the operating point well to the right on the remaining pump curve, increasing power and NPSHR. The two-way control valves close at part load, reducing flow, and increasing pump head, shifting the system curve to the left. A parallel pump controller can sense any of these effects, and automatically "destage" a pump at part load. Since most hydronic systems operate at part load most of the time, destaging can reduce energy costs significantly.

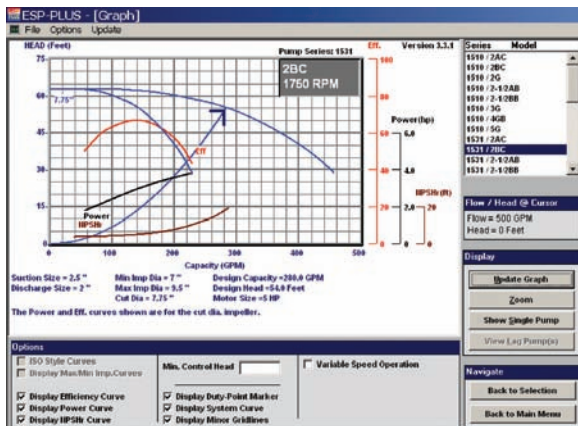

**Parallel Pumps  
Figure 38**

### Digital ESP PLUS

Just as ESP PLUS simplified and made pump selections easier and faster, the digital version of the System Syzer® calculator expands the use of the original plastic System Syzer® slide rule. The basic functions are identical:

### MBH/Flow/ $\Delta t$ relationship

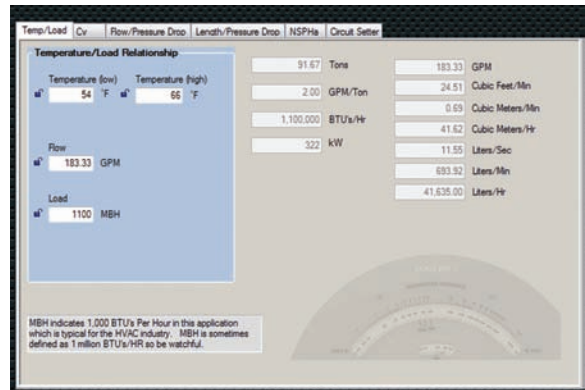

**ESP PLUS: Load, Flow and Delta Tee  
Figure 39**

In a previous design example, we used scale #1 to calculate required flow for 1,100,00 BTUH at 12° $\Delta t$ . The digital screen shows the same calculation. Though 60°F water is still the default value, this version has a fluids library with different concentrations of propylene or ethylene glycol anti-freeze. It also has an option to insert fluid properties to define a new fluid.

### Flow/Pressure drop/Pipe size/Velocity relationship

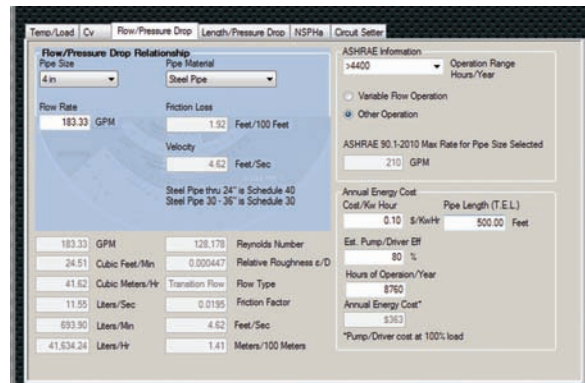

**ESP PLUS: Flow, Pipe size, Friction Loss Rate and Velocity  
Figure 40**

The 183 gpm calculated in the first screen automatically transfers to the next. A 4" pipe carrying 183 gpm would have acceptable friction loss rate and velocity, just as we saw with the plastic slide rule. For some flow rates, more than one pipe size will be acceptable in terms of friction loss rate and velocity. An experienced designer will apply judgment in choosing between these alternatives in order to improve system balance, or reduce pump head requirements.

Other information like viscosity, Reynolds number, flow regime and Darcy-Weisbach friction factor are shown in case a designer wants to make a more detailed analysis of the piping system.



**Total Equivalent Length/Friction Loss Rate/ Total Head LossESP PLUS: Total Equivalent length, Friction Loss Rate and Total Head Loss**

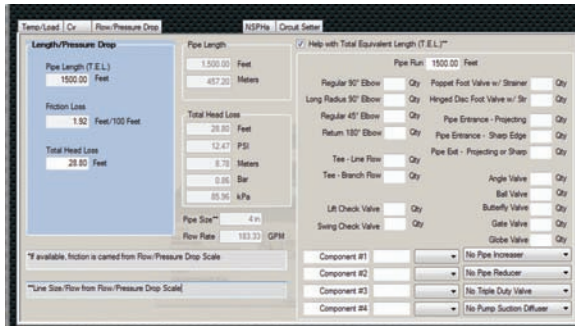

**Figure 41**

A 4" pipe carrying 183 gpm has a friction loss rate of 1.92 feet of head loss per 100 feet of TEL. If the system is 1500 feet long. The total head loss would be 28.8 feet.

**Note:** The System Syzer puts no limits on friction loss rate. The designer must use judgment in selecting the pipe size for a given value of flow in order to maintain the friction loss rate within the usual limits of 0.85 to 4.5 feet of head loss per 100 feet of equivalent length.

**System Curve/Cv/PSI to Feet of head conversion**



**ESP PLUS: System Curve, Cv  
Figure 42**

Using the values of head and flow developed in the design analysis, the Cv and points on the system curve can be calculated. Just as the plastic version allowed for easy conversion between psi and feet of head using the relationship of 2.31 feet of standard water equals 1 psi, the digital version adjusts for changes in fluid properties giving a more accurate result with different fluids.

**Circuit Analysis**

**Flow Coefficient, Cv**

The Cv of any component is defined as the flow in gpm that would pass through the component at a differential pressure of one psi. Mathematically:

$$C_v = \frac{GPM}{\sqrt{\Delta p}}$$

Control valves are often chosen by calculating the desired Cv, but any component's performance in the system could be described by its Cv. For example, a coil or a pipe, or even an entire fixed piping system has a Cv; the flow in gpm at one psi differential. The Cv can be displayed on Flow vs Pressure Drop coordinates. The system curve discussed earlier is an example.

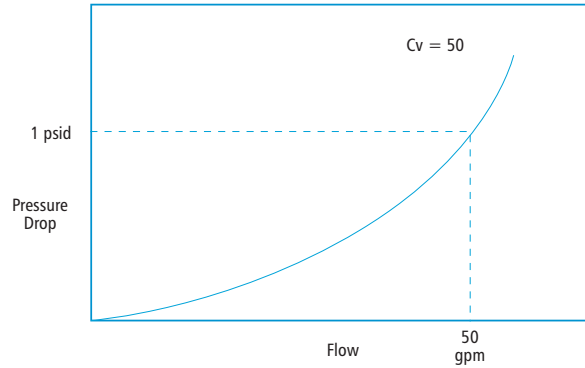

**Graphical Definition of Cv  
Figure 43**

This relationship is more useful than it may appear to be.

**Components in series**

Take a set of components in series. The flow through all is the same; the total pressure drop is the sum of the component pressure drops. Each component pressure drop can be stated in terms of its Cv:

$$\Delta p = \left[ \frac{GPM}{C_v} \right]^2$$

The total pressure drop through all components; a, b, c, ... is then:

$$\Delta p \text{ of the total} = \left[ \frac{GPM}{C_{va}} \right]^2 + \left[ \frac{GPM}{C_{vb}} \right]^2 + \left[ \frac{GPM}{C_c} \right]^2 +$$

The equivalent Cv of any number of things in series could be written as:

$$\frac{1}{\text{Equivalent } C_v^2} = \frac{1}{C_{va}^2} + \frac{1}{C_{vb}^2} + \frac{1}{C_{vc}^2} +$$

For two things with Cv1 and Cv2 in series:

$$\text{Equivalent CV} = \frac{C_{v1} \times C_{v2}}{\sqrt{C_{v1}^2 + C_{v2}^2}}$$

This expression can be useful in describing why modulating control valves must be selected for a substantial design pressure drop.

### Control Valve Authority

Suppose a control valve manufacturer has built a two-way modulating valve with a linear "inherent characteristic". That means the relationship between percentage of valve stem position and percentage of full flow must be linear. The manufacturer has controlled the shape of the valve plug and seat in order to give the expected performance.

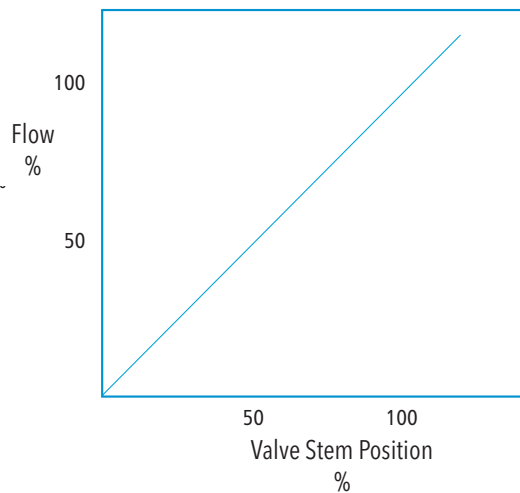

**Linear Inherent Characteristic**  
Figure 44

He might have used a test stand like this to test the completed valve.

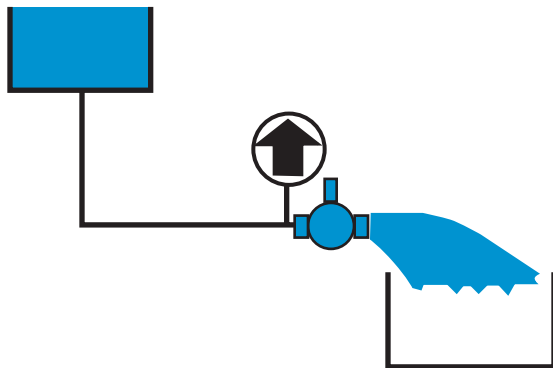

**Typical Valve Test**  
Figure 45

The water level in the tank remains at 2.3 feet to give a constant one psi at the valve inlet. The pressure at the valve outlet is 0 psi. The volume of water flowing for one minute can be weighed to determine the gpm. By means of this test, he could verify the characteristic, measuring flow at each increment of valve stem position.

When the valve is installed in an actual system, there will be some distortion of the inherent characteristic because of the resistance of the other components which are in series with the valve.

$$\text{Equivalent CV} = \frac{C_{v1} \times C_{v2}}{\sqrt{C_{v1}^2 + C_{v2}^2}}$$

Assume that Cv1 represents all the fixed components of the branch; things like pipes, elbows, and the coil. These

components cannot change their Cv because they cannot change their cross sectional area available for flow. Let Cv2 represent the Cv of the control valve. Unlike the other branch components, the valve can change its flow area and Cv. The equivalent Cv of the branch is determined by both the fixed and the variable components, hence the distortion.

Other components in series with the valve were not present during the test. Basic design data can be used to calculate the equivalent Cv of the branch and show how low pressure drop valves will result in greater distortion of the valve characteristic.

### Example:

Three different control valves will be used with a given coil to show the effect of selecting a low, medium, or high pressure drop valve.

If we consider just the two components, coil and valve, we can calculate the equivalent Cv of the two things in series. Note that the valve's Cv changes as it closes from 100% to 0%, but the coil Cv remains fixed. The coil can't change its Cv because it can't change the cross-sectional area available for flow. Flow in the coil-control valve combination does not change in the linear manner we expected when we selected the linear control valve.

### Control valve pressure drop equal to coil pressure drop. $\beta = 0.5/1.0 = 0.5$ (Curve B in Figure 46)

Valve Stem %	Valve Cv	Coil Cv	Equivalent Cv	Flow %
0	0	30	0	0
10	3	30	2.98	14
20	6	30	5.88	28
30	9	30	8.62	41
40	12	30	11.14	53
50	15	30	13.41	64
60	18	30	15.43	74
70	21	30	17.20	82
80	24	30	18.74	89
90	27	30	20.07	95
100	30	30	21.00	100

### Control valve pressure drop greater than coil pressure drop. $\beta = 0.9/1.0 = 0.9$ (Curve C in Figure 46)

Valve Stem %	Valve Cv	Coil Cv	Equivalent Cv	Flow %
0	0	30	0	0
10	1	30	0.99	10
20	2	30	1.99	21
30	3	30	2.98	31
40	4	30	3.96	42
50	5	30	4.93	52
60	6	30	5.88	62
70	7	30	6.81	72
80	8	30	7.72	81
90	9	30	8.62	91
100	10	30	9.48	100

**Control valve pressure drop less than coil pressure drop.  $\beta = 0.1/1.1 = 0.09$  (Curve A in Figure 46)**

Valve Stem %	Valve Cv	Coil Cv	Equivalent Cv	Flow %
0	0	30	0	0
10	9	30	9.06	30
20	19	30	16.05	53
30	28	30	20.66	69
40	38	30	23.54	78
50	47	30	25.36	84
60	57	30	26.54	88
70	66	30	27.35	91
80	76	30	27.90	93
90	88	30	28.41	95
100	95	30	30.00	100

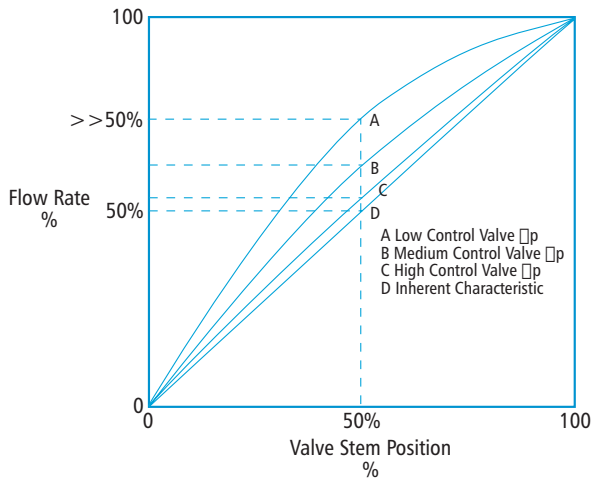

**Effect of Branch Authority on Part Load Flow Figure 46**

The ratio of control valve pressure drop to branch pressure drop is called the "branch authority". The figure shows that control valves selected for high pressure drop compared to the pressure drop of the rest of the branch have better authority, and less distortion of their inherent characteristic. In the earlier design examples, control valves were selected for appreciable pressure drop compared to the pressure drop of the rest of the branch in order to minimize the distortion of the valve's inherent characteristic as well as to promote "stable performance". Let's see the effect of valve authority on the stability of the system. The thermostatic temperature control in a heating system has detected a room temperature much higher than the thermostat setting. It sends a signal to the control valve telling it to go to 50% valve stem position, expecting that the branch flow will be reduced to 50% as predicted by the inherent characteristic of the valve.

- Valve A, with poor authority, will allow much more than 50% flow resulting in greater than required heat transfer and rising temperatures in the room. In time, the room will be so hot the temperature control system will have to restrict the flow severely. In effect, the valve tends to operate more like an "ON/OFF", or two position valve, rather than a modulating valve as intended.

- Valve B, with better authority, will provide better control since it is operating closer to the inherent characteristic.
- Valve C may have too much pressure drop leading to high total branch pressure drop and possibly valve cavitation: the formation and collapse of vapor bubbles in the liquid stream. Cavitation can result in early valve failure.
- Valve D represents an authority of 1.0. This can be achieved by using specially constructed pressure independent control valves, which use a little regulator system to maintain a fixed pressure difference across the valve's control orifice.

**Components in parallel**

Any number of components in parallel will have the same inlet pressure and the same outlet pressure. The pressure drop will be the same for all, but the total flow will be apportioned among them according to each branch's Cv. The branch with the largest Cv will get the greatest flow, but the total flow through all branches will be the sum of all.

$$Flow_{total} = C_{v1}\sqrt{\Delta p} + C_{v2}\sqrt{\Delta p} + C_{v3}\sqrt{\Delta p} + \dots$$

$$Equivalent\ C_v = C_{v1} + C_{v2} + C_{v3} + \dots$$

This explains the importance of achieving hydraulic balance among all the circuits of a multi-circuit system. Consider the system in Figure 47. The design point A, is 1100 gpm at 50 feet of head. The impeller must be trimmed to 11.625" diameter to meet this point. The system curve 0-A represents the desired balanced system, each branch receiving design flow.

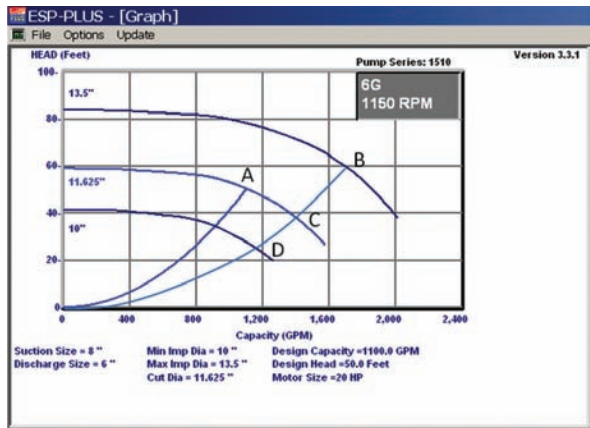

**Pump Curve with Balanced and Unbalanced Systems Figure 47**

Now suppose that one or more of the circuits has a greater Cv, or less resistance, at its design flow rate. Each of them will see a greater flow than is required to provide design heat transfer. System 0-B represents the unbalanced system. Even though the impeller is the right diameter, the pump will provide greater flow, and use more horsepower than required, point C. Point B shows the pump is oversized, providing more than the total flow required by all circuits. Each circuit will get more flow than it requires, operating costs will rise with no increase in occupant comfort. Point D represents an impeller that's

too small in the unbalanced system. In this case, the pump is still providing more than design flow, and that flow is not proportionately divided among the branches.

In the design examples, Circuit Setter balancing valves added just enough resistance in each of the lower pressure drop circuits to make each branch Cv equal to that of the highest pressure drop branch, the one used to select the pump. Balance valves used in this way result in "proportional balance" meaning that each branch will get its proper proportion of the flow from the pump. If the pump is selected properly, each branch will get exactly what it needs for design heat transfer. If the pump is over or under sized, each branch will get more or less than it needs, but all will see the same proportion of over or under flow.

## Appendix

### A. Pipe Friction Loss Nomogram

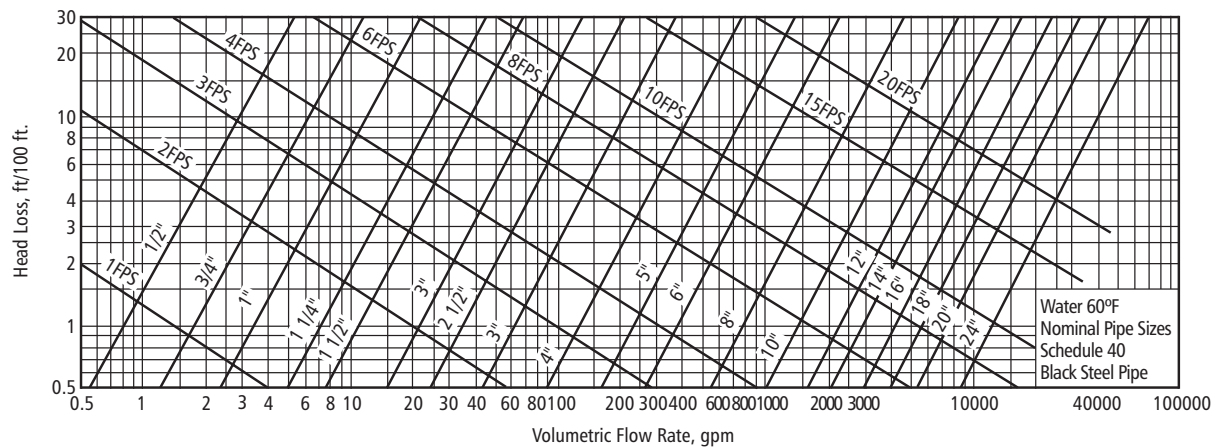





Find the design flow rate on the horizontal axis, proceed vertically to the intersection with the pipe size line. Read horizontally to the left to find friction head loss, find velocity by interpolation between lines of constant velocity. Example: 70 gpm in a 2½" Schedule 40 pipe will have a bit less than 4' / 100 Ft. of length at a velocity of about 5 f/s.

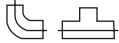

## C. Equivalent length of fittings

TABLE 2 FITTING EQUIVALENT LENGTH TABLE

Nominal Pipe Size	90° El or Tee: Flow Thru		Tee: Side Branch Flow In or Out		90° Miter	45° Miter	Valves		
							Gate	Globe	Plug
	Screw	Cu or Weld	Screw	Cu or Weld	Weld	Weld	All	All	All
1/2"	1	1/2	2	1	2 1/2	1/2	1/2	15	1
3/4"	2	1	4	2	4	3/4	1/2	20	1 1/2
1"	3	1 1/2	6	3	5	1	3/4	25	2
1 1/4"	3 1/2	1 3/4	7	3 1/2	6	1 1/4	1	30	2 1/2
1 1/2"	4	2	8	4	7 1/2	1 1/2	1 1/4	40	3
2"	5	2 1/2	10	5	10	2	1 1/2	50	4
2 1/2"	6	3	12	6	12 1/2	2 1/2	2	80	5
3"	8	4	16	9	15	3	2 1/2	90	6
4"		5 1/2		12	20	4	3	110	8
5"		8		15	25	5	3 1/2	140	10
6"		9		18	30	6	4	170	12
8"		11		24	40	8	5	240	16
12"		18		36	60	12	8	320	24

\* Applies to Side Branch Flow

### EXAMPLE 1:

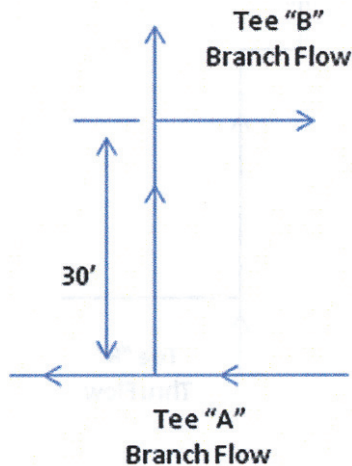

- Calculate friction loss from A to B given the following data:
  - Pipe Size is 3".
  - Flow is 130 GPM.
  - Measured length = 30'
  - Tee "A" is NPT with 3" run and 3" branch size.
- Determine fitting equivalent length:
  - From the Table, a threaded 3" tee with side branch has an equivalent length = 16'.
  - The equivalent length of the tee at "B" is not included for this section.
- Determine the Total Equivalent Length, TEL:
  - TEL = 30 + 16 = 46'
- Use scale #2 of the System Syze to determine the friction loss rate in a 3" pipe at 130 gpm, then scale #4 to find total head loss:
  - Scale 2: 3.8 ft/100 feet length
  - Scale 4: 2.2 ft head loss

### EXAMPLE 2:

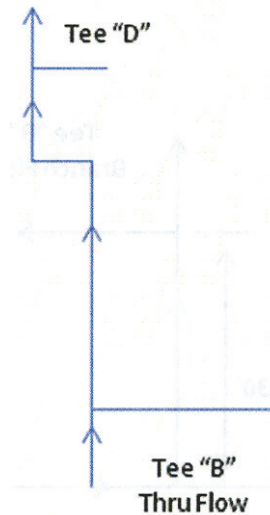

- Calculate friction head loss from B to D given:
  - Pipe Size is 3".
  - Flow is 120 GPM.
  - Measured length B to D is 40'
  - This section includes two 3" elbows and one 3" thru flow tee at point "B".
- Determine fitting equivalent length:
  - Two 3" elbows @ 8 each = 16
  - One 3" flow thru tee @ 4 = 4
- Total Equivalent Length = 40' + 16' + 4' = 60'
- Use scale 2 and 4 to determine the total head loss for 120 gpm in 3" pipe::
  - Scale 2: 3.3' ft/100 Ft.
  - Scale 4: 3.3'/100 Ft x 50' = 1.98 Feet

# HYDRONIC COMPONENTS LEGEND

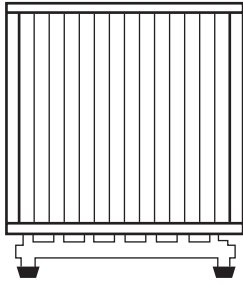

AIR EXCHANGER

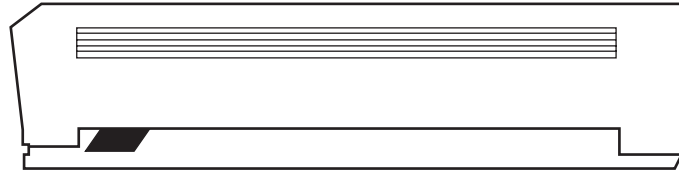

HEAT RUN



CIRCULATOR WITH ISOLATION FLANGE



CIRCULATOR



FITTING



AIR VENT

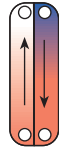

HEAT EXCHANGER

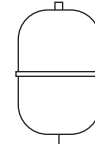

EXPANSION TANK

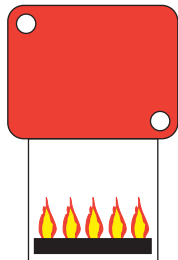

CONVENTIONAL BOILER



RADIANT PANEL



CIRCUIT SETTER



PRESSURE GAUGE

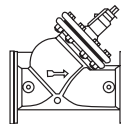

TRIPLE DUTY VALVE



ROLAIRTROL



DIVERTING VALVE



MIXING VALVE

# Xylem |'zīləm|

- 1) The tissue in plants that brings water upward from the roots;
- 2) a leading global water technology company.

We're 12,500 people unified in a common purpose: creating innovative solutions to meet our world's water needs. Developing new technologies that will improve the way water is used, conserved, and re-used in the future is central to our work. We move, treat, analyze, and return water to the environment, and we help people use water efficiently, in their homes, buildings, factories and farms. In more than 150 countries, we have strong, long-standing relationships with customers who know us for our powerful combination of leading product brands and applications expertise, backed by a legacy of innovation.

**For more information on how Xylem can help you, go to [www.xyleminc.com](http://www.xyleminc.com)**



Xylem Inc.  
8200 N. Austin Avenue  
Morton Grove, Illinois 60053  
Phone: (847) 966-3700  
Fax: (847) 965-8379  
[www.bellgossett.com](http://www.bellgossett.com)

Bell & Gossett is a trademark of Xylem Inc. or one of its subsidiaries.  
© 2012 Xylem Inc. TEH-908A December 2012