

Series e-1510 Centrifugal Pumps



Series e-1510 End Suction Pump System

The Series e-1510 provides the highest overall efficiency in the end-suction market for HVAC and plumbing applications. With the largest Efficiency Island compared to other similar pumps, the e-1510 reduces electricity consumption, improves overall system performance and lowers life cycle costs.

The extensive efficiency profile enables users to maintain significantly higher levels of efficiency over a much wider range of operating conditions. The Series e-1510's dramatic improvement in efficiency is the result of cutting edge computational fluid dynamics (CFD) design technology, extensive hydraulic engineering expertise, and Xylem's comprehensive knowledge of HVAC and plumbing applications. The Bell & Gossett Series e-1510 is available in 26 sizes and a variety of configuration options that enables customization and flexibility to fit a broad range of operating conditions.

Applications

- Chilled Water
- Commercial HVAC
- Hydronic Heating and Cooling Systems
- Cooling Towers and Industrial Uses



Series e-1510 installation



Take away these seven standard features and you'll have a pump like everyone else's.



True Back Pullout

A B&G standard in design and construction. Ease in service is assured, while piping and motor remain undisturbed. Extended delays for repairs are virtually eliminated.



Solid-Foot Mounted Volute

All Series e-1510 pumps are provided as standard with an integrally cast volute foot located directly beneath the pump volute. This integrally cast foot ensures that the alignment between the volute and motor assembly is maintained. Without solid

support beneath the volute, the piping weight alone will cause distortion which can lead to premature failure of the bearings, shaft and mechanical seal. This feature is equally important on hot water applications. The Series e-1510 volute foot provides a solid foundation and eliminates the deflections which would otherwise exist within an unsupported overhung volute during the normal thermal expansion of the system piping against the volute.

Internally Self-Flushing Mechanical Seal

This design is way ahead of its time. This unique seal design is proven in many years of service. It requires no special external flushing provisions, since the design provides for constant efficient flushing action internally. This standard feature ensures maximum seal face lubrication, heat dissipation and debris removal without vulnerable, external flush tubing. The internal flushing action passes two and a half to three times the flow over the seal faces – compared to a few GPM for conventional, stuffing-box designed pumps.



Stainless Steel Impellers

The e-1510's optimized hydraulic designs offer large efficiency "islands" maximizing operating efficiency over wide ranges of performance. e-1510 impellers are precision cast stainless steel providing extremely smooth surface finishes and tight dimensional tolerances to further yield higher efficiencies. Stainless

steel impellers are also more resilient than bronze impellers, providing owners with longer lasting maximum efficiency levels and applications over a wider range of fluids.



Center Drop-Out Spacer Coupling

Unlike conventional jaw type or rigid style couplings, a center drop-out spacer coupling allows removal of the bearing frame and rotating element without disturbing the pump end pipe alignment or motor electrical connections.



OSHA-Compliant Coupling Guard

The coupler guard complies with OSHA 1910.219. The guard offers increased protection against potential injuries and is standard on all e-1510 pumps. The guards include slotted viewing windows for easy inspection.

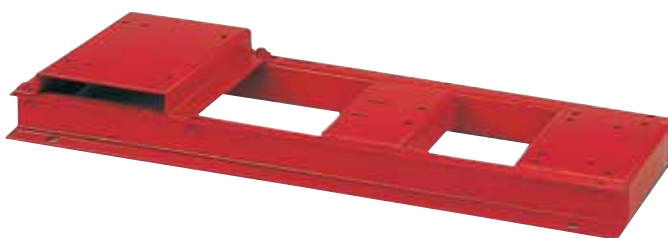

Heavy Duty, Rugged Baseplate

The Bell & Gossett fabricated heavy duty baseplate is supplied as standard on every Series e-1510 pump. Unlike rolled steel and "C" channel baseplates, the Series e-1510 baseplate provides a heavy duty saddle assembly, full seam welds, closed baseplate ends and an open top to provide ease of access for proper equipment grouting.

Materials of Construction

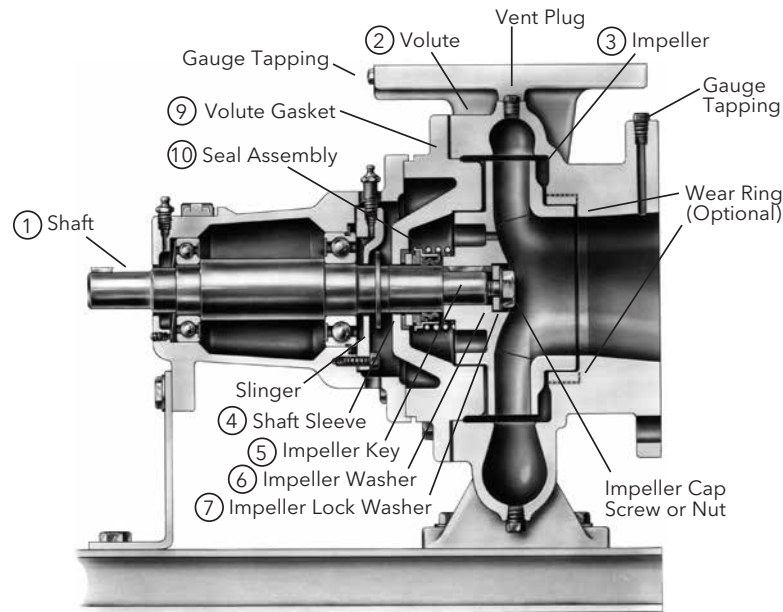

Standard Configuration

Description	SM, LG, & XL Bearing Frames	ES Bearing Frame
1 Shaft	ASTM 108 Grade 1144	ASTM 108 Grade 1144
2 Volute	Cast Iron ASTM A48 Class 30B or Ductile Iron	Cast Iron ASTM A48 Class 30B
3 Impeller	ASTM A743 Grade CF8 - 304 Stainless Steel	ASTM A743 Grade CF8 - 304 Stainless Steel
4 Shaft Sleeve	ASTM 312 Grade TP304 - 304 Stainless Steel	ASTM 312 Grade TP304 - 304 Stainless Steel
5 Impeller Key	#304 Stainless Steel	NA
6 Impeller Washer	Steel	NA
7 Impeller Lock Washer	#304 Stainless Steel (18-8 XL FRM)	NA
8 Impeller Cap Screw	#304 Stainless Steel	NA
8 Impeller Nut	NA	316 Stainless Steel
9 Volute Gasket	Cellulose Fiber	Cellulose Fiber
10 Seal Assembly	Reference Seal Data Tables	Reference Seal Data Tables

Pump Options

- Stainless Steel Volute Wear Ring
- Galvanized Steel Drip Pan
- Stainless Steel Shaft
- Rexnord Omega Spacer Coupling
- Falk T31 Spacer Coupling
- External Flush Line
- Stuffing Box Configuration
- Epoxy Coated Internal Cast Iron Components
- Special Impeller Balancing (ISO 1940 G2.5 or G1.0)
- Certified Performance Tests (Per HI Standard 14.6)
- 250 PSI Working Pressure
- ITSC or IT Control

Seal Assemblies

Standard Mechanical Configuration

Standard Mechanical Seal	SM, LG, & XL Bearing Frames	ES Bearing Frame
Temperature Range	-20 to 225°F	-20 to 225°F
Maximum Pressure	175 PSI	175 PSI
pH Limitations	7.0 - 9.0	7.0 - 9.0
Elastomer	Buna	Buna
Rotating Face	Carbon	Carbon
Stationary Face	Ceramic	Silicon Carbide
Hardware	Stainless Steel / Brass	Stainless Steel

Mechanical Seal Options	SM, LG, & XL Bearing Frames		
Temperature Range	-20 to 250°F	-10 to 225°F	-20 to 250°F
Maximum Pressure	175 PSI	175 PSI	175 PSI
pH Limitations	7.0 - 11.0	7.0 - 9.0	7.0 - 12.5
Elastomer	EPR (Ethylene Propylene Rubber)	FKM (Viton™ or Fluoroelastomer)	EPR (Ethylene Propylene Rubber)
Rotating Face	Carbon	Carbon	Silicon Carbide
Stationary Face	Tungsten Carbide	Ceramic	Silicon Carbide
Hardware	Stainless Steel / Brass	Stainless Steel	Stainless Steel

Mechanical Seal Options	ES Bearing Frame		
Temperature Range	-20 to 250°F	-10 to 225°F	-20 to 250°F
Maximum Pressure	175 PSI	175 PSI	175 PSI
pH Limitations	7.0 - 11.0	7.0 - 9.0	7.0 - 12.5
Elastomer	EPR (Ethylene Propylene Rubber)	FKM (Viton™ or Fluoroelastomer)	EPR (Ethylene Propylene Rubber)
Rotating Face	Silicon Carbide	Carbon	Silicon Carbide
Stationary Face	Tungsten Carbide	Silicon Carbide	Silicon Carbide
Hardware	Stainless Steel / Brass	Stainless Steel	Stainless Steel

Stuffing Box Configuration

Mechanical Seal	SM, LG, & XL Bearing Frames
Temperature Range	-20 to 250°F*
Maximum Pressure	175 PSI (Optional 250 PSI)
pH Limitations	7.0 - 11.0
Elastomer	EPR (Ethylene Propylene Rubber)
Rotating Face	Tungsten Carbide
Stationary Face	Carbon
Hardware	Stainless Steel

* For operating temperatures above 250°F a cooled flush is required and is recommended for temperatures above 225°F for optimum seal life. On closed systems cooling is accomplished by inserting a small heat exchanger in the flush line to cool the seal flushing fluid.

Flush-line Filters and Sediment Separators are available on special request.

Series e-1510 Performance Curves

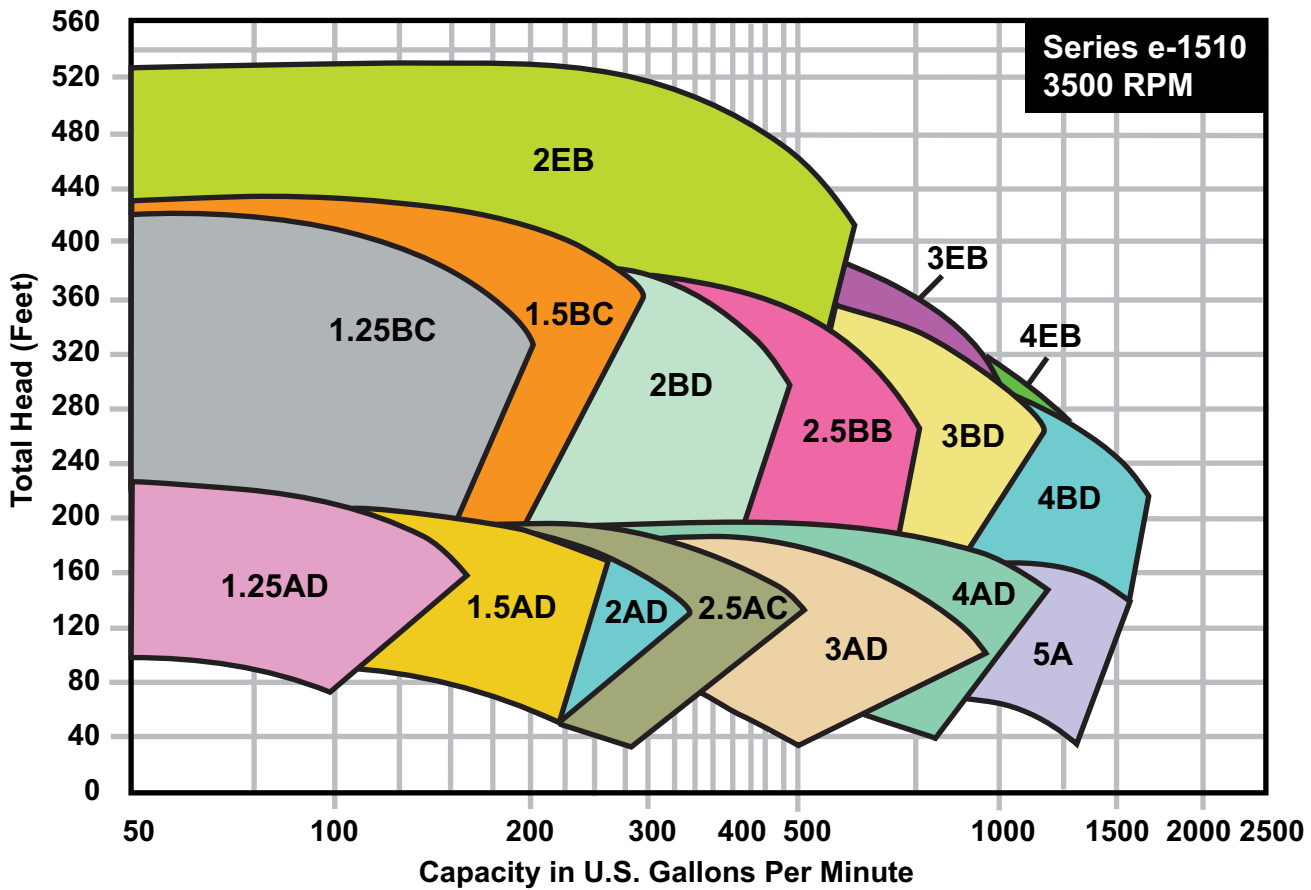
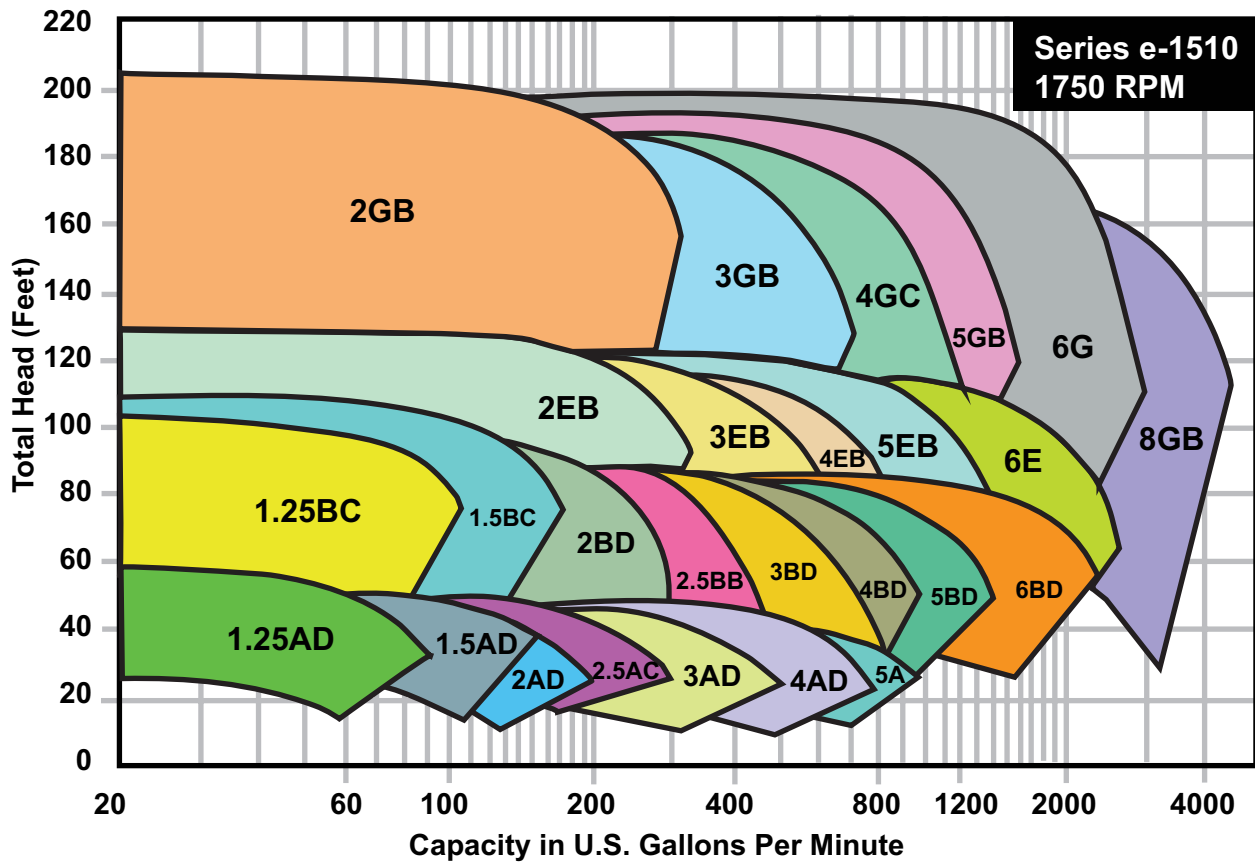

The Bell & Gossett End Suction Pump System

Consists of:

B&G Series e-1510 Pump

B&G Triple Duty® Valve

B&G Suction Diffuser Plus

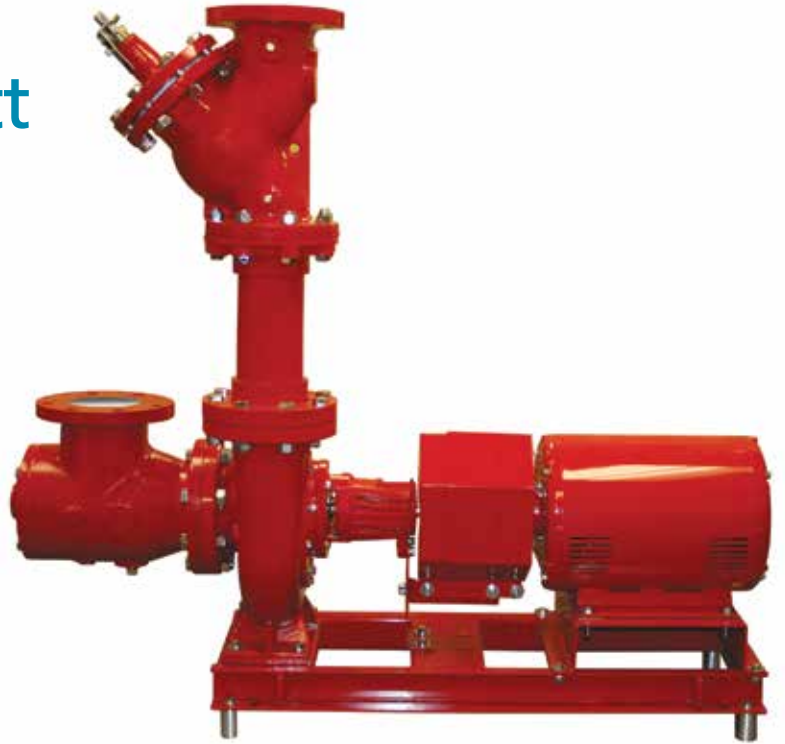

Triple Duty Valve

- Lowest Pressure Drop
- ASHRAE 90.1 Energy Efficient Design
- Three Valves in one!
 - Nonslam drip-tight check valve
 - Positive shutoff valve
 - Calibrated system balance valve
- EPDM Disc Soft Seat Design
- Repack Under Pressure
- Brass Seat & Bronze Disc
- Stainless Steel Stem
- Multi-turn Valve (8-9 turns) vs 1/4 turn range of control
- Available connections - Threaded - Flanged - Grooved
- ESP-Systemwise Selection



Suction Diffuser Plus

- Flow Cone (patent pending) eliminates recirculation zones, directing flow toward the pump and improving flow conditioning
- Full length straightening vanes assure uniform flow pattern for pump inlet
- Large diameter orifice cylinder prevents debris from entering pump suction while maintaining low pressure drop.
- Fine mesh throwaway start-up strainer assures cleaner, more trouble free system
- Optional pressure/temperature ports permit checking of system conditions and verification of start-up strainer presence
- Eliminates the need for separate long radius elbows or reducing elbows
- Common installation dimensions compared to previous B&G designs making retrofits easy.
- Easily removable end cap with reusable o-ring
- Plug/blow down connection permits routine maintenance

Typical Specification for Series e-1510 Base Mounted, Flexible Coupled, End-Suction Pumps

Furnish and install pumps with performance characteristics as shown on plans. Pumps shall be base mounted, single stage, end suction design with a foot mounted volute to allow removal and service of the entire rotating assembly without disturbing the pump piping, electrical motor connections or pump to motor alignment.

Pump volute shall be Class 30 cast iron or ductile iron with integrally-cast pedestal support feet. The impeller shall be a cast stainless steel enclosed type, balanced to ISO 1940-1 balance grade G6.3 and secured to the shaft by a locking capscrew or nut.

The liquid cavity shall be sealed off at the pump shaft by an internally-flushed mechanical seal with ceramic seal seat and carbon seal ring, suitable for continuous operation at 225°F (107°C). A replaceable stainless steel shaft sleeve shall completely cover the wetted area under the seal.

Pump shall be rated for minimum of 175 psi (12 bar) working pressure. Volute shall have gauge tapings at the suction and discharge nozzles and vent and drain tapings at the top and bottom.

The pump(s) vibration limits shall conform to Hydraulic Institute ANSI/HI 9.6.4-2009 for recommend acceptable unfiltered field vibration limits (as measured per ANSI/HI 9.6.4 (2016) Figure 9.6.4.2.3.1) for pumps with rolling contact bearings.

Baseplate shall be of structural steel or fabricated steel channel with fully enclosed sides and ends, and securely welded cross members. Grouting area shall be fully

open. The combined pump and motor baseplate shall be sufficiently stiff as to limit the susceptibility of vibration. The minimum baseplate stiffness shall conform to ANSI/HI 1.3.8.2.1-2013 for grouted Horizontal Baseplate Design standards.

A flexible type, center drop-out design coupling, capable of absorbing torsional vibration, shall be employed between the pump and motor. Pumps for variable speed application shall be provided with a suitable coupling sleeve. The coupling shall be shielded by a rated OSHA 1910.219 compliant coupling guard and contain viewing windows for inspection of the coupling.

Motor shall meet NEMA and EISA 2014 (where applicable) specifications and shall be of the size, voltage and enclosure called for on the plans. Pump and motor shall be factory aligned, and shall be realigned by the contractor per factory recommendations after installation.

The pump(s) selected shall conform to ANSI/HI 9.6.3 (2017) standards for Preferred Operating Region (POR) unless otherwise approved by the engineer.

Each pump shall be factory hydrostatically tested per Hydraulic Institute standards. It shall then be thoroughly cleaned and painted with at least one coat of high grade paint prior to shipment.

The pump(s) shall be manufactured, assembled and tested in an ISO 9001 approved facility.

Series e-1510 pumps are manufactured by Bell & Gossett, a Xylem, Inc. brand.

We value your feedback. Please take our 3 question survey at bellgossett.com/survey to let us know how we are doing.



Xylem Inc.
8200 N. Austin Avenue
Morton Grove, Illinois 60053
Phone: (847) 966-3700
Fax: (847) 965-8379
www.xylem.com/bellgossett

Bell & Gossett is a trademark of Xylem Inc. or one of its subsidiaries.
© 2021 Xylem Inc. B-313F R2 February 2021